



APPLICATION SPECIFICATION

2.0mm PITCH W/B CONN. DURACLIK™ ISL SERIES APPLICATION GUIDE

[PURPOSE AND SUMMARY]

이 지침서는 한국 몰렉스의 2.0mm PITCH W/B CONN. DURACLIK™ ISL (INDEPENDENT SECONDARY LOCK) SERIES의 HEADER ASSY 제품 및 상대물 FEMALE CONNECTOR에 대한 취급 매뉴얼 목적으로 사용한다. (HEADER ASSY (R/A) : 502352 시리즈, HEADER ASSY (S/T) : 560020 시리즈, FEMALE CONNECTOR : 560123 시리즈, ISL RETAINER : 560125 시리즈, FEMALE TERMINAL : 560124 시리즈)

THE PURPOSE OF THIS MANUAL IS TO BE USED FOR USING 2.0mm PITCH W/B CONN. DURACLIK™ ISL (INDEPENDENT SECONDARY LOCK) SERIES, HEADER ASSY PARTS AND COUNTER PARTS OF FEMALE CONNECTOR (HEADER ASSY (R/A) : 502352 SERIES, HEADER ASSY (S/T) : 560020 SERIES, FEMALE CONNECTOR : 560123 SERIES, ISL RETAINER : 560125 SERIES, FEMALE TERMINAL : 560124 SERIES)

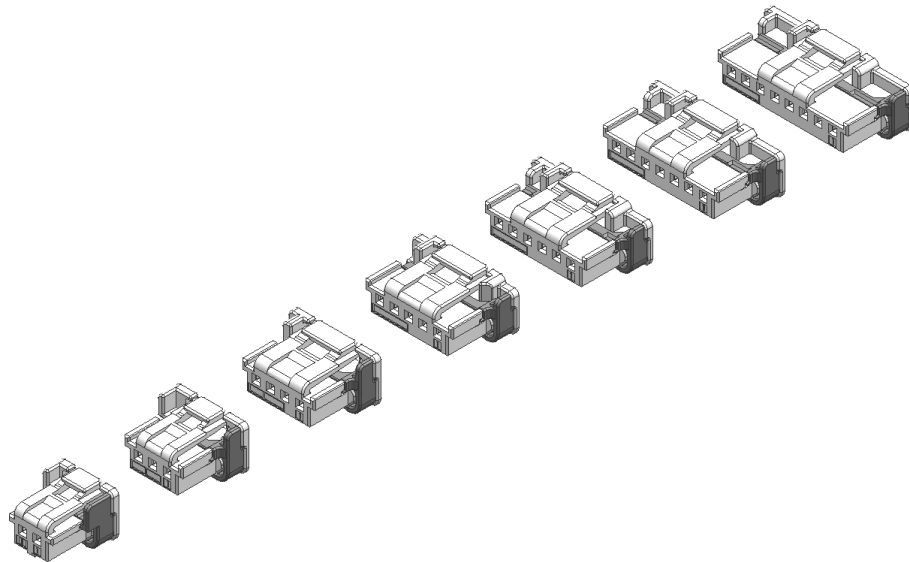

Table of Contents

- Section 1 : Product Introduction**
- Section 2 : Product Summary (Connector & Terminal Assembly)**
- Section 3 : Service Instruction (Rework Method)**
- Section 4 : Precaution During Continuity Inspection**
- Section 5 : Product Name and Part Number**

REVISION: A	ECR/ECN INFORMATION: EC No: KTR 2016-0063 DATE: 2016 / 03 / 21	TITLE: <u>DURACLIK™ ISL APPLICATION GUIDE</u>	SHEET No. 1 of 10
DOCUMENT NUMBER: AS-560123-001	CREATED / REVISED BY: SJ Lee	CHECKED BY: BC Yoon	APPROVED BY: JY Choi



APPLICATION SPECIFICATION

1.0 PRODUCT INTRODUCTON

Characteristic and Standard

몰렉스 DuraClik™ 2.00mm (.079") pitch wire-to-board interconnect system은 진동 환경의 기기를 위한 PCB에 대한 고정과 안정적인 접속을 제공하며, 이는 wiper/blinker levers, front/back lights 및 기타 운송 수단의 내부 응용 기기에 이상적으로 적합하다.

자동차용 응용 기기의 Lighting module은 광원의 안정성과 무결성을 유지하기 위하여 더욱 높은 단자의 유지력을 요구하였다. 이에 대하여 Molex's DuraClik™ 2.0mm pitch connectors ISL Series는 ISL (Independent Secondary Lock) Retainer 구조의 단자 고정 장치를 통하여 50N 이상의 단자 유지력을 확보 하였으며, 단자 원재료는 특수 동합금을 적용하여 경쟁되는 제품 보다 뛰어난 성능으로 고객 규격에 적합한 125°C의 고온 환경에 적용이 가능하다.

새로운 Female Housing과 Retainer는 양산 제품인 DuraClik™ headers (502352 R/A, 560020 S/T)에 적용 가능하며, 공간 절약, 접속 안정성 및 체결 보호의 502351 DuraClik™ 규격과 같은 Inner-lock system을 제공한다.

본 제품은 DuraClik™ ISL Female Terminal (560124)를 적용하며 적용 Wire 사양은 AVSS 0.3Sq, FLRY-A 0.35Sq가 적용 가능하며, 기타 제품관련 상세한 사항은 <http://www.molex.com> 사이트에 방문하여 상세 사양을 확인할 수 있다.

DuraClik™ 2.00mm (.079") pitch wire-to-board interconnect system provide fixation on PCB and stable connectivity for equipment of vibration environment. This is suitable for wiper/blinker levers, front/back lights and other internal applied equipment of transportation etc.

Lighting module of transportation applied equipment is required to have high retention force of terminal for maintaining light source and integrity. As to Molex's DuraClik™ 2.0mm pitch connectors ISL Series, it has more than 50N retention force through ISL (Independent Secondary Lock) Retainer structure. Raw Material is special copper alloy which could be applied in high temperature such as 125°C. New Female Housing and Retainer would be applied to DuraClik™ headers (502352 R/A, 560020 S/T) which already got down to Mass Production. It's space efficiency and reliable connectivity and Inner-lock system such as 502351 DuraClik™. This product is applied to DuraClik™ ISL Female Terminal (560124) and applied wire specification is AVSS 0.3Sq, FLRY-A 0.35Sq. If you want to know about more detail things, please visit <http://www.molex.com>

REVISION: A	ECR/ECN INFORMATION: EC No: KTR 2016-0063 DATE: 2016 / 03 / 21	TITLE: <u>DURACLİK™ ISL APPLICATION GUIDE</u>	SHEET No. 2 of 10
DOCUMENT NUMBER: AS-560123-001	CREATED / REVISED BY: SJ Lee	CHECKED BY: BC Yoon	APPROVED BY: JY Choi



APPLICATION SPECIFICATION

2.0 PRODUCT SUMMARY

Female Connector & TPA (ISL Retainer)

커넥터는 아래 그림과 같이 Female Housing과 ISL Retainer로 각각 최종 공급한다.
 ISL Retainer는 고객사에 공급되어 모든 적용 단자들이 체결된 Female Housing에 체결해야 한다.
 Female Housing and ISL Retainer would be applied as below. ISL Retainer would be supplied to customer and they need to mate it with Female Housing applied all terminals.

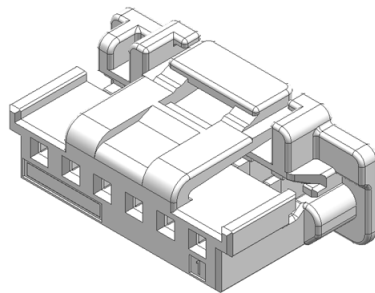

Female Connector

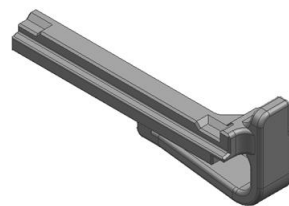

ISL Retainer

TPA Connector Housing 체결방법

TPA의 HSG 체결방법은 아래 그림과 같다. 적용 단자가 모두 조립된 Female HSG에 TPA의 삽입 방향을 확인 후 하단 Locking부에서 "딸깍" 소리가 날 때까지 삽입한다.
 Assembly method between TPA and HSG is as below. After you check out insertion direction of TPA on Female HSG applied terminal, you insert it until you hear 'clack' on the bottom side of locking area.

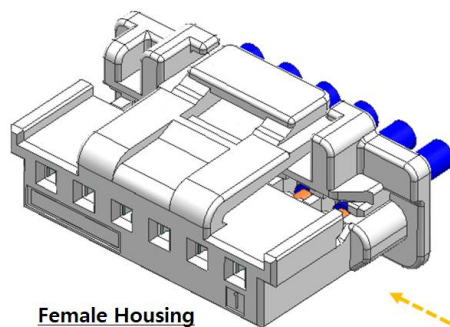

Female Housing with Terminals

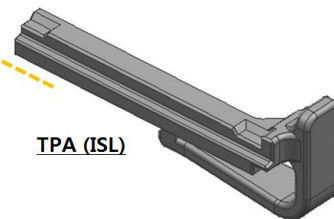

TPA (ISL)

REVISION: A	ECR/ECN INFORMATION: EC No: KTR 2016-0063 DATE: 2016 / 03 / 21	TITLE: <u>DURACLIC™ ISL APPLICATION GUIDE</u>	SHEET No. 3 of 10
DOCUMENT NUMBER: AS-560123-001	CREATED / REVISED BY: SJ Lee	CHECKED BY: BC Yoon	APPROVED BY: JY Choi



APPLICATION SPECIFICATION

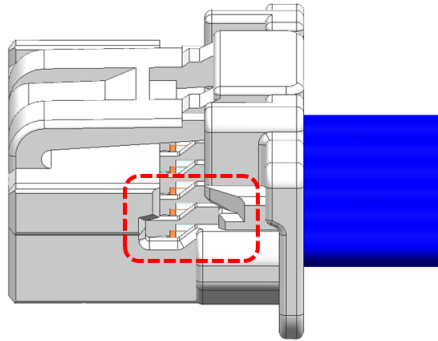

Check the Direction of TPA insertion

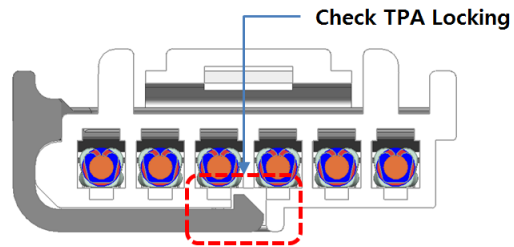

Section View

Check TPA Locking

How to assemble Header Assembly & Female Connector

Header Assembly 제품에 Female Connector를 체결할 때, 제품의 Key-Coding 형상에 주의하며 Female Connector의 Locking부의 “딸깍” 소리가 날 때까지 삽입하여 체결을 한다.

작업자 작업 실수를 방지하고자 Fool-Proof 형상을 적용하여 입구부터 결합이 되지 않도록 하였으나, 작업 도중 고의의 과도한 힘으로 강제 삽입 시 제품이 파손 및 변형될 수 있으니 주의한다.

When mating Header Assembly with Female Connector, Need to be cautious about Key-coding form and insert it until you hear 'clack' on the locking area of Female Connector. We applied Fool-proof method from the entrance so as to prevent operator mistake. However, please aware that it could be broken or deformed if operator insert it by force.

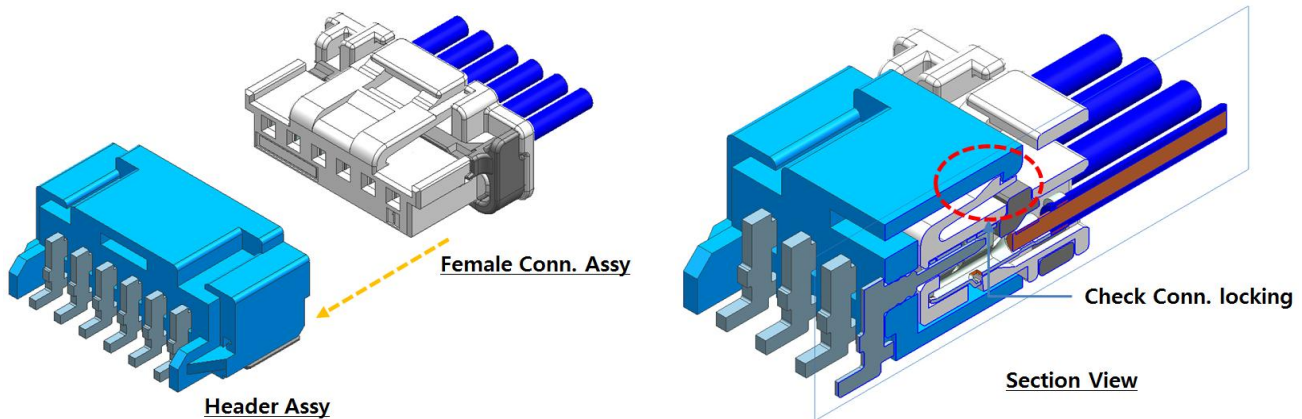

Header Assy

Female Conn. Assy

Section View

Check Conn. locking

REVISION: A	ECR/ECN INFORMATION: EC No: KTR 2016-0063 DATE: 2016 / 03 / 21	TITLE: <u>DURACLIC™ ISL APPLICATION GUIDE</u>	SHEET No. 4 of 10
DOCUMENT NUMBER: AS-560123-001	CREATED / REVISED BY: SJ Lee	CHECKED BY: BC Yoon	APPROVED BY: JY Choi



APPLICATION SPECIFICATION

- 커넥터 KEY-CODE 형상 : HEADER 및 FEMALE 하우징 별 KEY-CODE 형상 및 위치로 구분되어 해당 되는 상대 제품에 체결 됨. (아래그림 참조)
- Connector Key-code form : Header and female housing are separated by Key-code form and location. those are applied to mating parts. (please refer to below picture.)

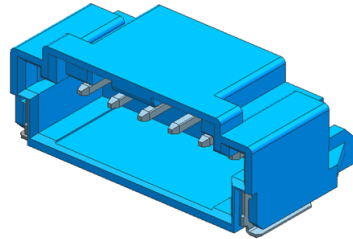

DuraClik 6P Header Assy

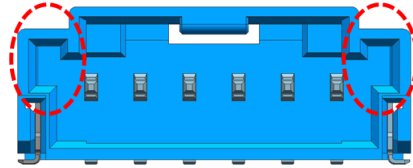

Front View & Key-Code

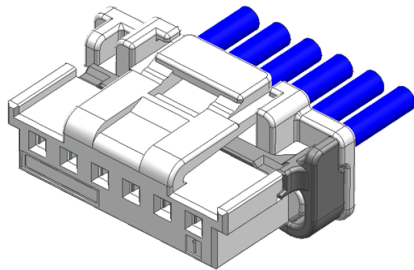

DuraClik ISL 6F Connector Assy

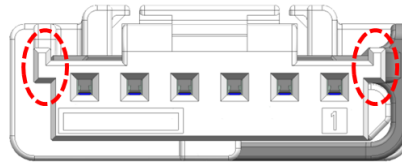

Front View & Key-Code

REVISION: A	ECR/ECN INFORMATION: EC No: KTR 2016-0063 DATE: 2016 / 03 / 21	TITLE: <u>DURACLİK™ ISL APPLICATION GUIDE</u>	SHEET No. 5 of 10
DOCUMENT NUMBER: AS-560123-001	CREATED / REVISED BY: SJ Lee	CHECKED BY: BC Yoon	APPROVED BY: JY Choi



APPLICATION SPECIFICATION

3.0 SERVICE INSTRUCTION

How to mate terminal

아래의 그림과 같이 커넥터 후방에서 단자의 체결을 시작한다. 단자 삽입 시 오조립 방지를 위한 방향성을 가지고 있으므로 주의하고, 해당 단자를 하우징 끝 단까지 밀어 넣어 "딸깍" 소리가 들릴 때까지 삽입하여야 한다. 단자 체결 후 삽입 반대 방향으로 Wire를 조심히 당겨 단자가 Lance에 체결되었는지 확인한 후 단자 체결을 완료한다.

Terminal would be mated from the back side of connector as below. When inserting terminal, there's directivity to prevent mis-assembly. Insert terminal to the end of housing until you hear 'clack'. Pull out wire in the opposite direction of insertion after mating terminal so as to check whether terminal has been mated with Lance or not.

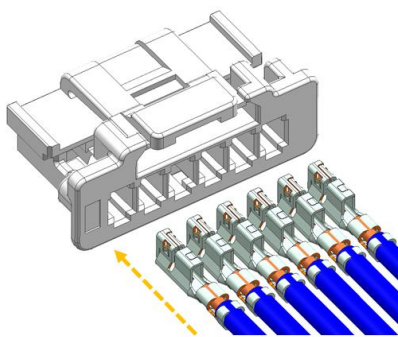

Insert Female Terminal into Housing

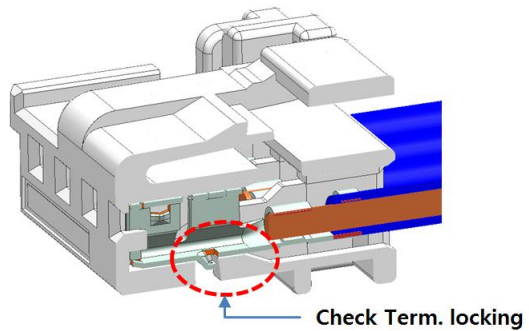

Push crimped Terminal until "Click" Locking Sound

REVISION: A	ECR/ECN INFORMATION: EC No: KTR 2016-0063 DATE: 2016 / 03 / 21	TITLE: <u>DURACLIC™ ISL APPLICATION GUIDE</u>	SHEET No. 6 of 10
DOCUMENT NUMBER: AS-560123-001	CREATED / REVISED BY: SJ Lee	CHECKED BY: BC Yoon	APPROVED BY: JY Choi

Mating method of TPA

아래의 그림과 같이 단자가 체결된 Female Connector에 TPA의 삽입 방향을 확인한 후 하단 Locking부에서 “딸깍” 소리가 날 때까지 삽입한다. 이때 TPA가 삽입되지 않는 경우 단자의 정 위치를 확인 한 후 TPA를 다시 체결한다. (단자 중도 삽입 검지 기능)

As you can see below, Insert TPA from the bottom side of locking area until you hear 'clack' after checking TPA insertion direction on Female connector. If TPA has not been inserted, check out the position of terminal and re-insert TPA (Detector function for terminal insertion)

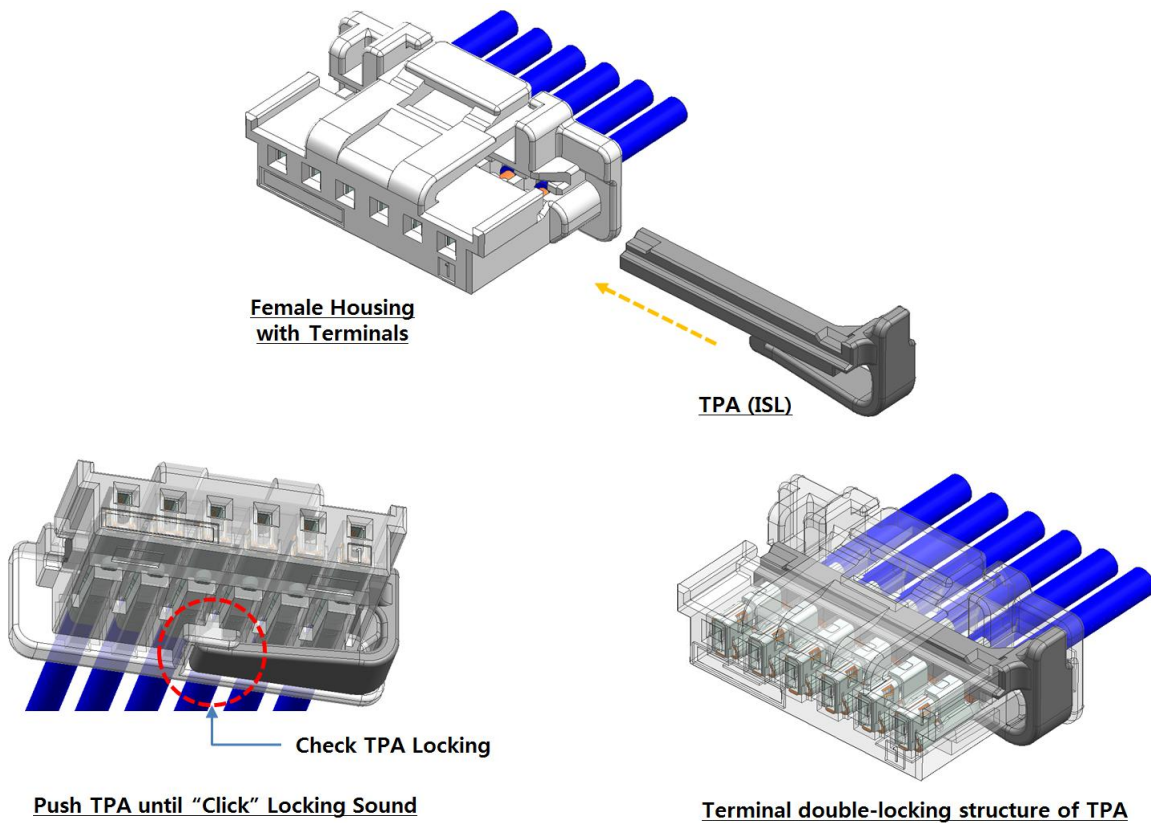

REVISION: A	ECR/ECN INFORMATION: EC No: KTR 2016-0063 DATE: 2016 / 03 / 21	TITLE: <u>DURACLIC™ ISL APPLICATION GUIDE</u>	SHEET No. 7 of 10
DOCUMENT NUMBER: AS-560123-001	CREATED / REVISED BY: SJ Lee	CHECKED BY: BC Yoon	APPROVED BY: JY Choi



APPLICATION SPECIFICATION

Terminal Rework Method

범용 툴 ('-'형 드라이버)을 이용하여 완전 체결된 TPA의 Lock (커넥터의 하단에 위치)을 들어 올려 해제한 후 슬라이드 방향으로 당겨 하우징으로 부터 완전히 탈거한다. 단자 또한 범용 툴을 이용하여 Housing의 Lance를 들어 올린 후 Wire를 당겨 단자를 탈거 한다.

(Rework한 Housing은 가능한 폐기 하고 새로운 Housing 사용을 권장한다)

First of all, lift and remove the lock (located on bottom side of connector) of TPA through common tool such as '-'-shape driver. Need to remove it from housing through pulling out to slide direction. After lifting up lance of housing through terminal and common tool, remove terminal through pulling out wire.

(It is recommended for use new Housing after rework.)

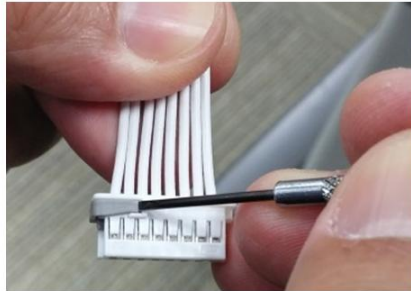

TPA is lifted up to Locking by using Tool



Remove TPA

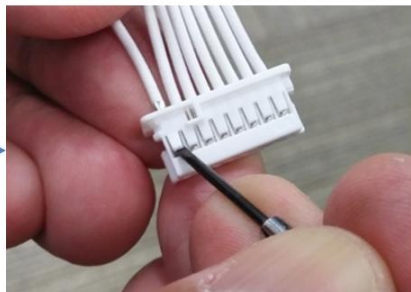

Lance is lifted up to Locking by using Tool



Remove Terminal

REVISION: A	ECR/ECN INFORMATION: EC No: KTR 2016-0063 DATE: 2016 / 03 / 21	TITLE: <u>DURACLIC™ ISL APPLICATION GUIDE</u>	SHEET No. 8 of 10
DOCUMENT NUMBER: AS-560123-001	CREATED / REVISED BY: SJ Lee	CHECKED BY: BC Yoon	APPROVED BY: JY Choi

4.0 PRECAUTION DURING CONTINUITY INSPECTION

1) 통전 테스트 및 와이어링 하네스에서 사용하는 어떤 툴이라도 커넥터에 체결 시 하우스 및 단자의 변형을 주어서는 안되기 때문에 매우 정확하게 테스트를 수행해야 한다.

1) Test should be correct because any tool using for current test and wiring harness shouldn't give deformation on housing and terminal while mating connector

2) 아래의 그림에서 보여준 것과 같이 테스트 Probe 가 체결되는 단자의 Hole로 단자의 변형 없이 접촉되어야 한다.

2) As below picture, Test probe should be contacted with terminal hole without deformation.

3) Probe는 ICT 검사 (통전 및 내 전압 검사)가 수행될 동안 접촉되어 있어야 한다.
(테스트 기기와 연결된 모니터에 합격 판정이 나오기 까지 접촉되어 있어야 한다)

3) Probe should be contacted during ICT test.

(It should be contacted until monitor linked with test equipment says OK)

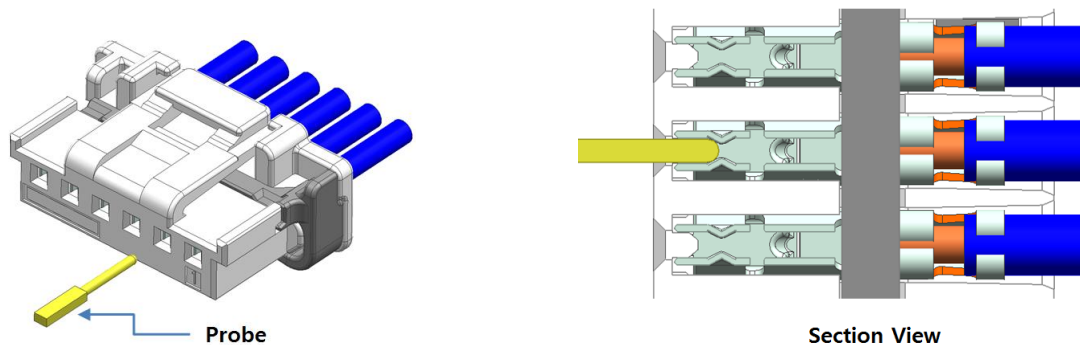

Terminal Hole Dim's	the maximum pushing the terminal	the maximum pulling the terminal

<025 terminal pin location and measurement>

REVISION: A	ECR/ECN INFORMATION: EC No: KTR 2016-0063 DATE: 2016 / 03 / 21	TITLE: DURACLIK™ ISL APPLICATION GUIDE	SHEET No. 9 of 10
DOCUMENT NUMBER: AS-560123-001	CREATED / REVISED BY: SJ Lee	CHECKED BY: BC Yoon	APPROVED BY: JY Choi



APPLICATION SPECIFICATION

5.0 PRODUCT NAME AND PART NUMBER

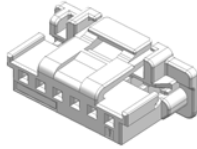
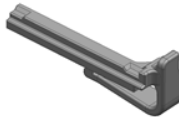
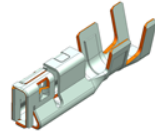
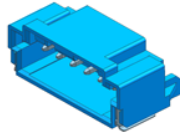
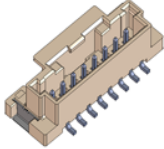
	Product Name		Part Number	Remark
Wire Side	Receptacle Housing		560123 series	
	Retainer		560125 series	
	Receptacle terminal		560124 series	
PCB Side	Wafer Assembly	Right Angle Type	502352 series (EMBOSS package)	
		Vertical Type	560020 series (EMBOSS package)	

- The End -

REVISION: A	ECR/ECN INFORMATION: EC No: KTR 2016-0063 DATE: 2016 / 03 / 21	TITLE: <u>DURACLIC™ ISL APPLICATION GUIDE</u>	SHEET No. 10 of 10
DOCUMENT NUMBER: AS-560123-001	CREATED / REVISED BY: SJ Lee	CHECKED BY: BC Yoon	APPROVED BY: JY Choi