

May.1.2023 Copyright 2023 HIROSE ELECTRIC CO., LTD. All Rights Reserved.  
In case of consideration for using Automotive equipment / device which demand high reliability, kindly contact our sales window correspondents.

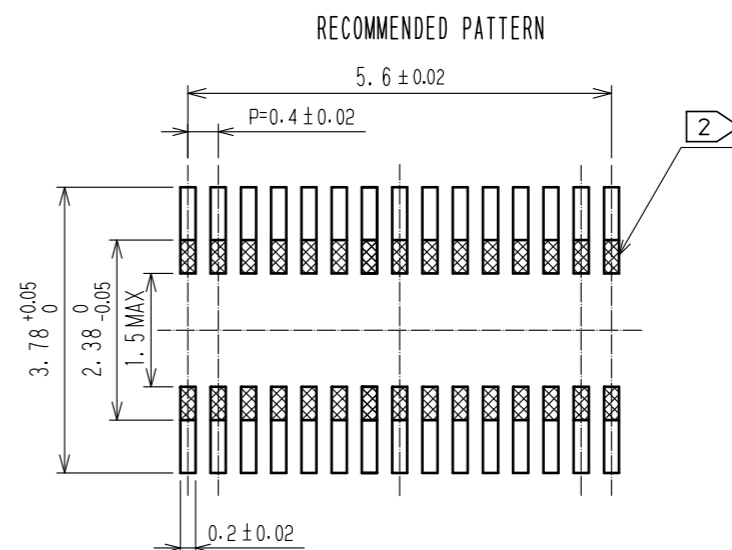

RECOMMENDED METAL MASK THICKNESS: 120 μm  
RECOMMENDED MASK OPENING RATIO: 80% FOR LEAD PAD

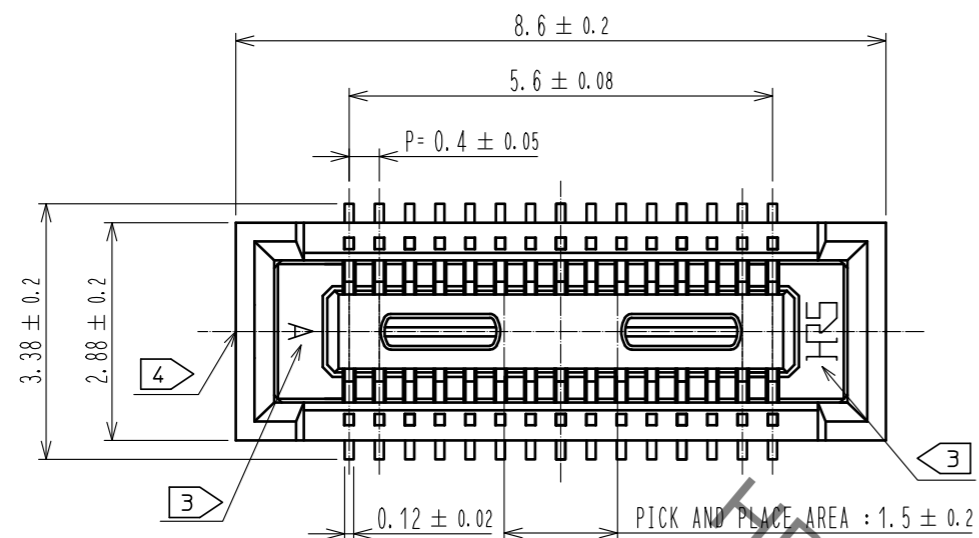
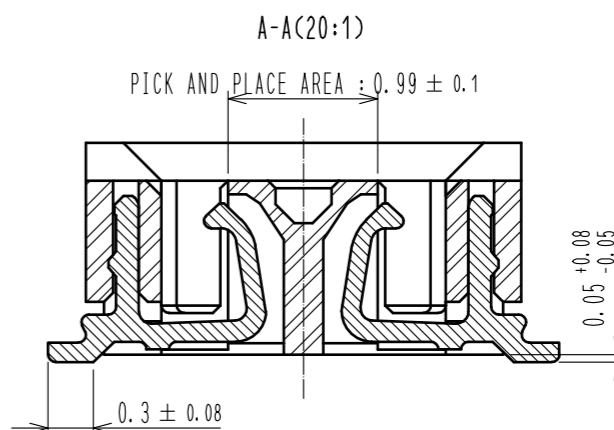
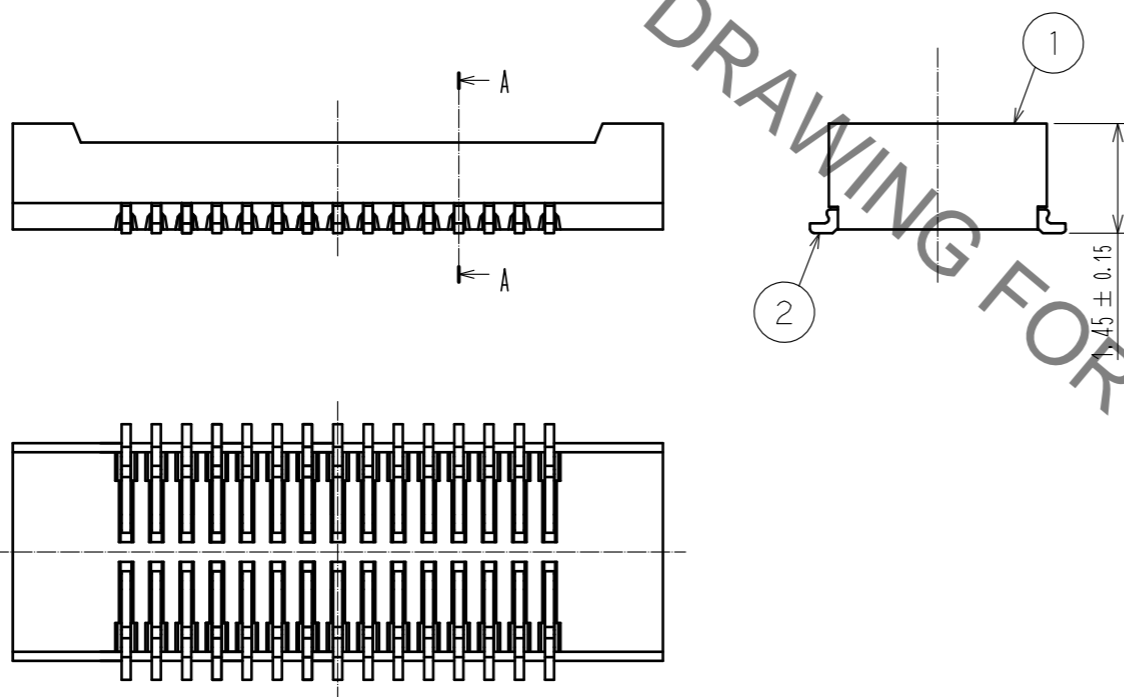

ENGAGEMENT FIGURE (20:1)

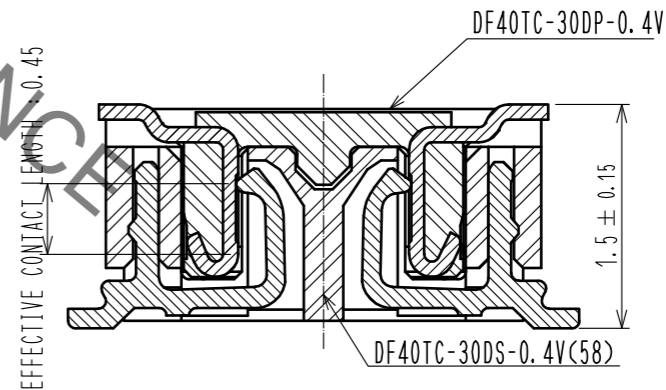

- NOTES) 1. ALL LEADS METAL FITTINGS CO-PLANARITY SHALL BE 0.1mm MAX.  
 2. IS NO PATTERN AREA OTHER THAN THE SAME CIRCUIT.  
 3. HRS MARK AND CAV NO. ARE INDICATED IN APPROXIMAL POSITION SHOWN.  
 4. GATE IS LOCATED IN APPROXIMAL AREA.

2	COPPER ALLOY	CONTACT AREA: GOLD 0.05 μm MIN	6	PS	CLEAR, REINFORCEMENT COLLAR			
		SMT LEAD: GOLD 0.05 μm MIN	5	PS	BLACK, PLASTIC REEL			
		UNDERPLATING: NICKEL 1 μm MIN	4	POLYESTER	CLEAR, COVER TAPE			
1	LCP	BLACK, UL94V-0	3	PS	CLEAR, EMBOSSED CARRIER TAPE			
NO.	MATERIAL	FINISH, REMARKS	NO.	MATERIAL	FINISH, REMARKS			
UNITS mm		SCALE 10:1	COUNT 	DESCRIPTION OF REVISIONS		DESIGNED	CHECKED	DATE
APPROVED: WR. FUKUCHI			20210303	DRAWING NO.		EDC-386684-58-00		
CHECKED: TS. MIYAZAKI			20210303	PART NO.		DF40TC-30DS-0.4V(58)		
DESIGNED: YK. SATAKE			20210303	CODE NO.		CL0684-4261-0-58		
DRAWN: YK. SATAKE			20210303					

May.1.2023 Copyright 2023 HIROSE ELECTRIC CO., LTD. All Rights Reserved.  
 In case of consideration for using Automotive equipment / device which demand high reliability, kindly contact our sales window correspondents.

EMBOSED CARRIER TAPE PACKAGING (5:1)

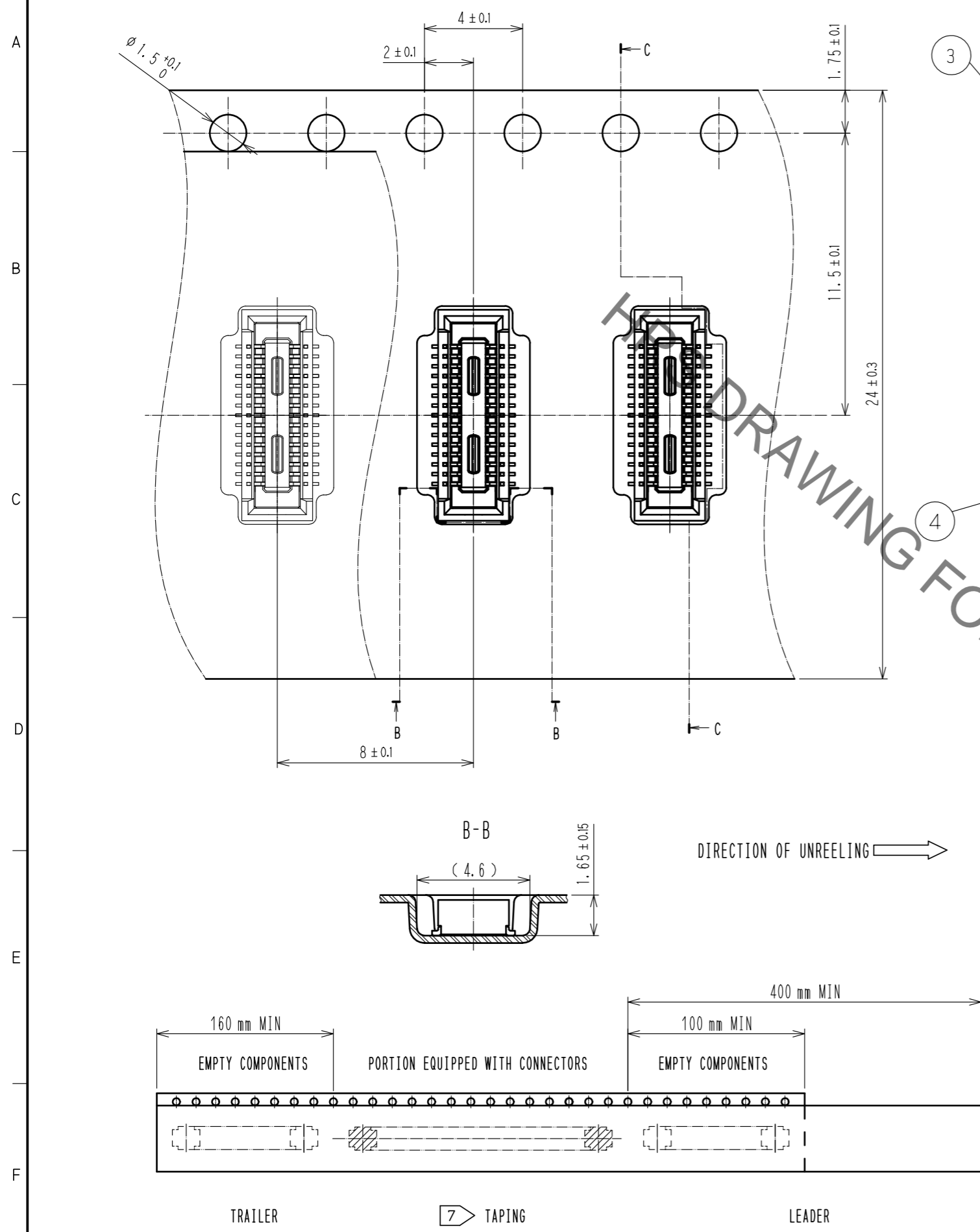

STYLE AND DIMENSION OF REEL(FREE)

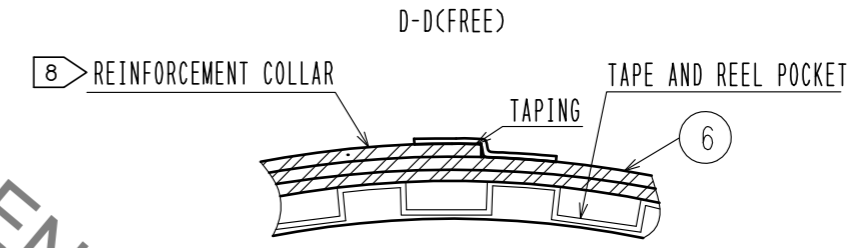
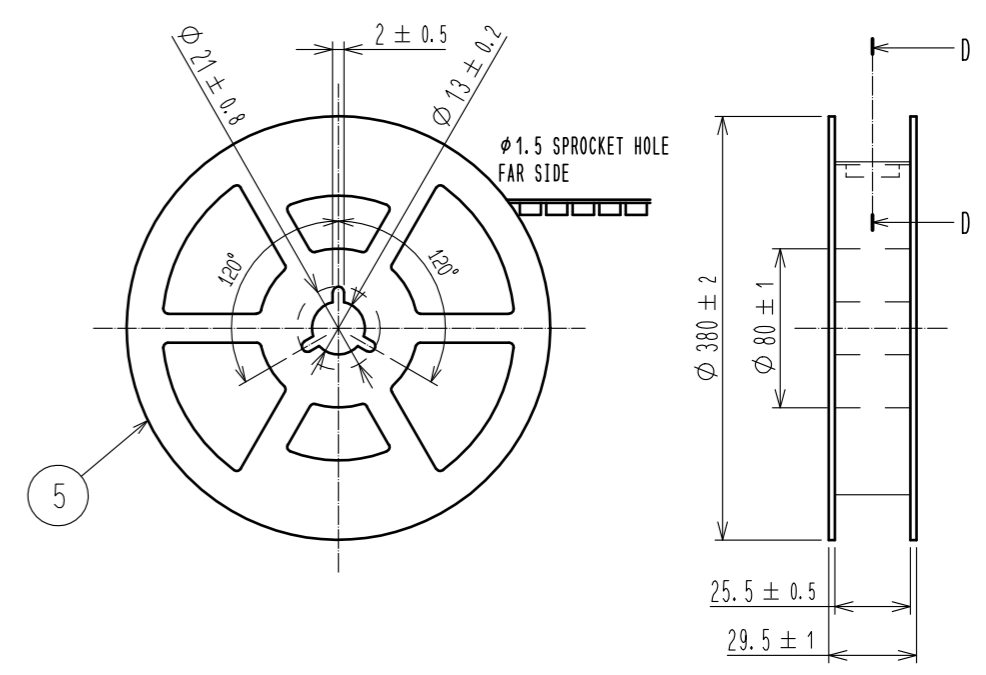

- NOTES
5. PER REEL 1000 CONNECTORS.
  6. THE DIMENSIONS IN PARENTHESES ARE FOR REFERENCE.
  7. REFER TO JIS C 0806, IEC 60286-3 (PACKING OF COMPONENTS FOR AUTOMATIC HANDLING)
  8. AFTER PACKAGING, ROLL 2 METERS OF THE REINFORCEMENT COLLAR TO OUTER CIRCUMFERENCE OF TAPE AND REEL POCKET. AND TAPE DOWN AT THE END THE COLLAR.

<b>HRS</b>	DRAWING NO.	EDC-386684-58-00
	PART NO.	DF40TC-30DS-0.4V(58)
	CODE NO.	CL0684-4261-0-58
		2/2