

LDH100



Oil humidity sensor

OIL HUMIDITY SENSOR

For 8-pole sockets the core colours are not standardised.
Please note the wiring of the sensor and the sockets (see data sheet).

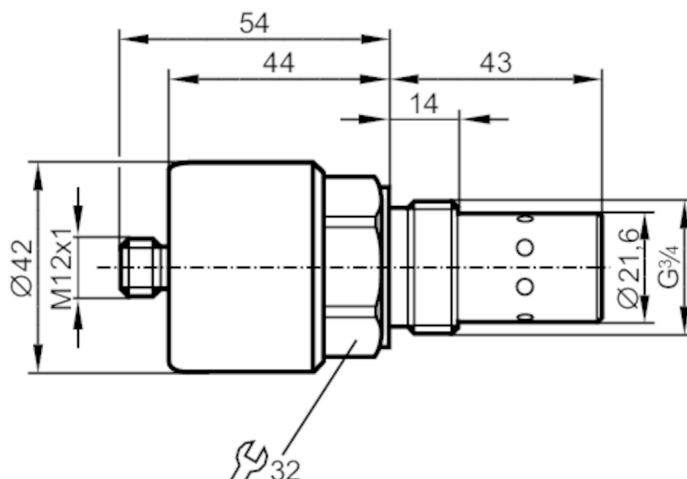

Product characteristics

Number of inputs and outputs	Number of analogue outputs: 2
Process connection	G 3/4

Application

Media	mineral oils; synthetic esters; biodegradable oils
Tank pressure [bar]	50

Oil

Medium temperature [°C]	-40...105
-------------------------	-----------

Electrical data

Operating voltage [V]	9...33 DC
Current consumption [mA]	< 25
Protection class	III
Reverse polarity protection	no
Measuring principle	capacitive

Inputs / outputs

Number of inputs and outputs	Number of analogue outputs: 2
------------------------------	-------------------------------

Outputs

Total number of outputs	2
Number of analogue outputs	2
Analogue current output [mA]	4...20
Max. load [Ω]	(U _b - 8) x 25
Resolution of analogue output	φ: 1% / T: 0.1 K

LDH100



Oil humidity sensor

OIL HUMIDITY SENSOR

Measuring/setting range	
Temperature monitoring	
Measuring range	[°C] -20...120
Accuracy / deviations	
Accuracy	φ : $\pm 3\%$ / T: $\pm 2\%$
Response times	
Response time	[s] 1.3
Operating conditions	
Ambient temperature	[°C] -40...85
Storage temperature	[°C] -40...85
Max. relative air humidity	[%] 100
Protection	IP 67
Tests / approvals	
EMC	EN 13309
	IEC 61000-6-2 : 2005
	IEC 61000-6-4 : 2006 + AMD1: 2010
Vibration resistance	test following DIN EN 60068-2-6
MTTF	[years] 90
Mechanical data	
Weight	[g] 176.5
Materials (wetted parts)	aluminium; HNBR; polyurethane resin; epoxy resin
Process connection	G 3/4
Remarks	
Remarks	accuracy values expressed in percent refer to the measuring span
Pack quantity	1 pcs.
Electrical connection	

Connector: 1 x M12; coding: A

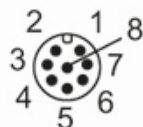

LDH100



Oil humidity sensor

OIL HUMIDITY SENSOR

Connection

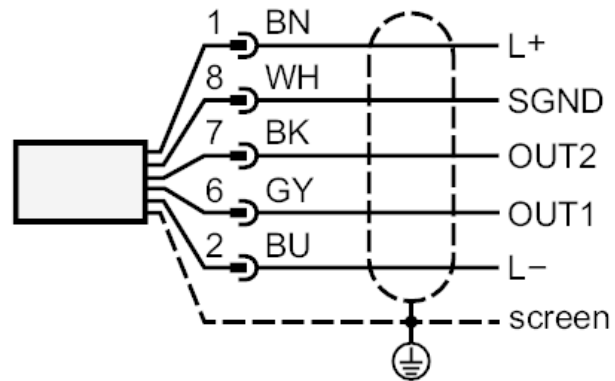

SGND: signal ground
OUT1: oil temperature
OUT2: relative humidity