

May.1.2023 Copyright 2023 HIROSE ELECTRIC CO., LTD. All Rights Reserved.
In case of consideration for using Automotive equipment / device which demand high reliability, kindly contact our sales window correspondents.

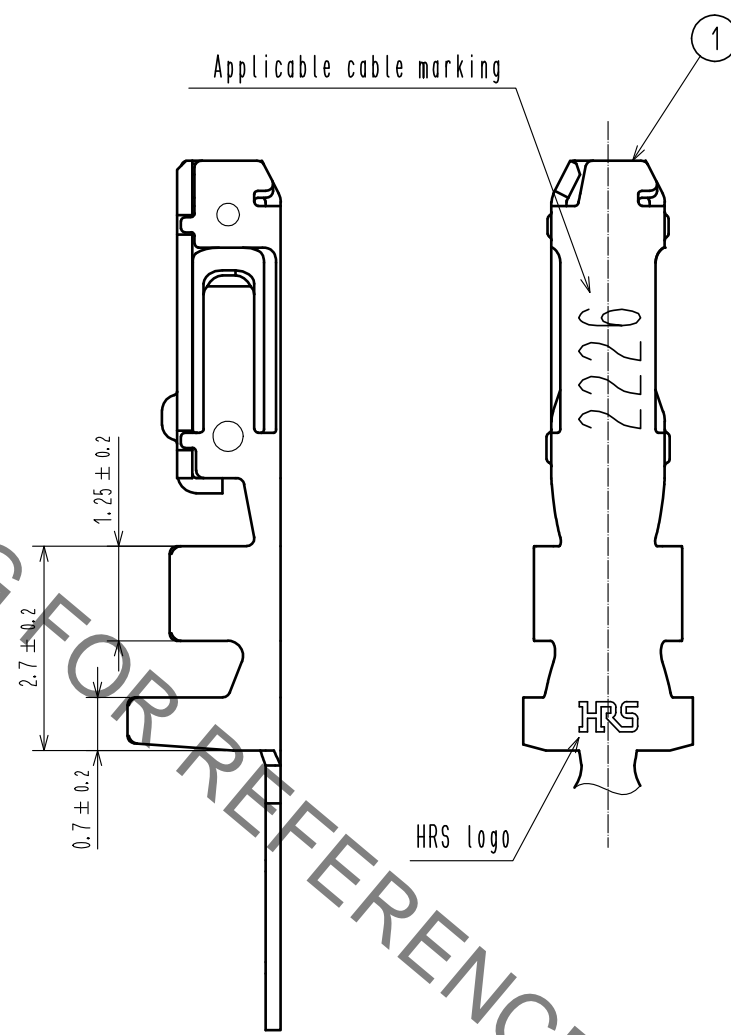

2 Reel style and dimensions

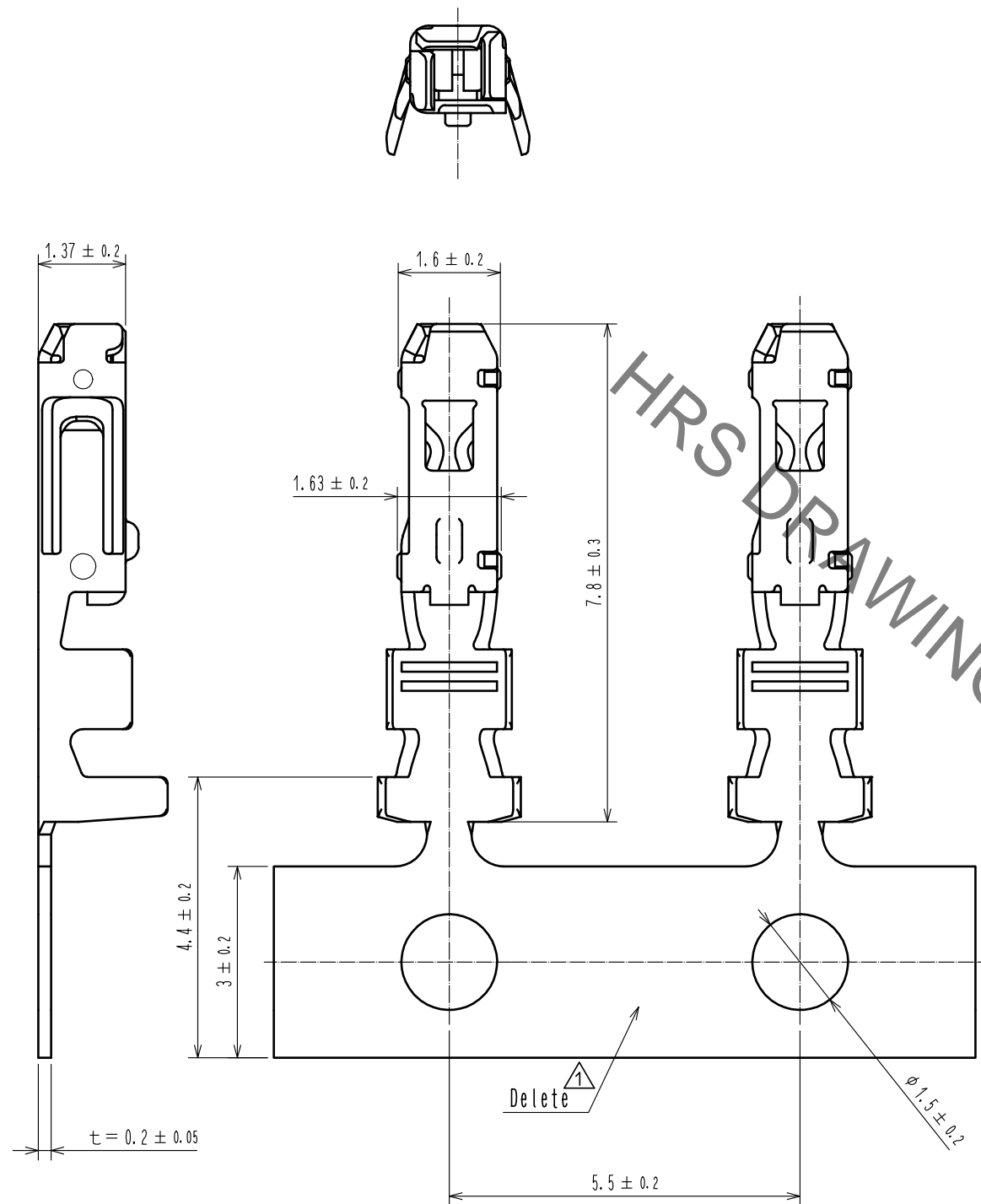
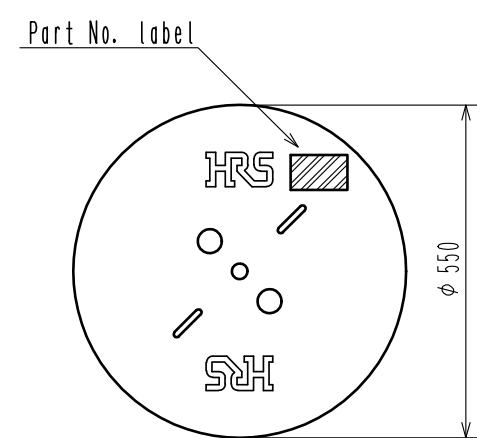

Detail of part No. Label

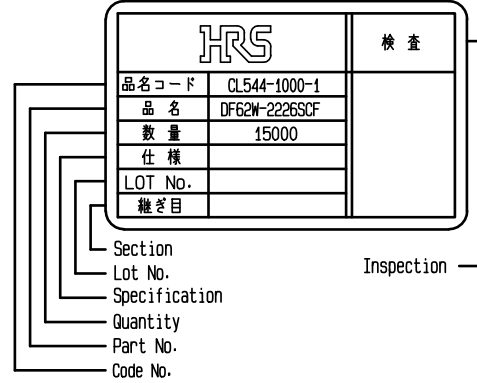

Notes

1. 1RL : 15000 contacts.
2. Style of reel and box are shown in figure.
3. Up to 5 reels are packed up in one box.
4. Please be sure to check the form of crimping using a cable when you adjust applicator.
5. Always refer to the manuals below for operation of this product.
For Cable assembly / Cable assembly procedure ETAD-H0760
For Mating/Unmating / Operation manual ETAD-H0761

NO.	MATERIAL	FINISH . REMARKS	NO.	MATERIAL	FINISH . REMARKS
			1	Phosphor bronze	Tin plating : 1μm MIN
UNITS mm		SCALE 10 : 1	COUNT 1	DESCRIPTION OF REVISIONS DIS-H-00001433	DESIGNED YK. YAMAGUCHI
			APPROVED : KI. AKIYAMA	14. 01. 15	CHECKED TS. FUKUSHIMA
			CHECED : MN. KENJO	14. 01. 15	DATE 16. 03. 03
			DESIGNED : KT. ISHII	14. 01. 14	
			DRAWN : KT. ISHII	14. 01. 14	
HRS HIROSE ELECTRIC CO., LTD.			DRAWING NO. EDC-353515-00-00		
			PART NO. DF62W-2226SCF		
			CODE NO. CL544-1000-1-00		