

1

2

3

4

5

6

7

A

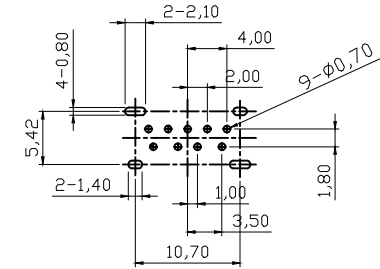
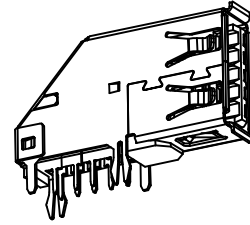
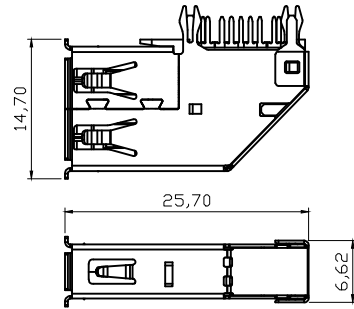
① **USB3.0 COMPLIANT**

Recommended PCB Layout  
Tolerance For PCB Layout is  $\pm 0.05$

B

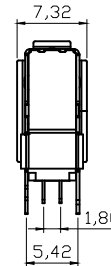
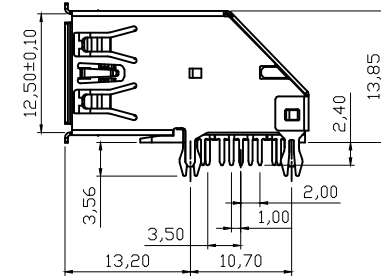
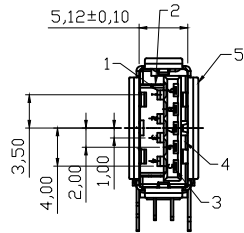

C

D

E

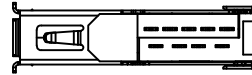

- Specifications:
- ② Current Rating: 1.8Amp For Pin1 & Pin4  
0.25Amp other contacts  
Insulation Resistance: 100Mohm Min  
Dielectric Withstanding :100V(RMS)  
Contact Resistance: 20mohm Max For Pin1 & Pin4  
50mohm Max other contacts
  - ③ Voltage Rating: 30VAC
  - ② Mechanical Characteristics:  
Mating Cycle:1500 cycle Min.  
Mating Force: 35N Max  
Un-mating Force: 10N Min  
Operating Temperature: -55°C To + 85°C
  - ③ Soldering Temperature: +235°C, 5s max.  
Packing: Tray

Pin Number	Signal Name	Pin Number	Signal Name	Item	Part Name	Material	QTY	Remark	
1	VBUS	5	SSRX-	1	4P Semi-manufactured goods	Housing	PBT	1	Blue UL94V-0
2	D-	6	SSRX+	2		Contact	Copper Alloy	4	T=0.25 Selective 15u" Au/Tin
3	D+	7	GND	3	5P Semi-manufactured goods	Housing	PBT	1	Blue UL94V-0
4	GND	8	SSTX	4		Contact	Copper Alloy	5	T=0.25 Selective 15u" Au/Tin
Shell	Shield	9	SSRT+	5	Shell	SUS304-1/2H	1	T=0.30	

F

G

**RoHS compliant**  
Unit: mm

Scale	Free					Date	Name	Customer-No.
TOLERANCE					Drawn	14.03.2012	Lucas	ASSMANN WSW-No. <b>A-USB3 A-E</b>
X.	±0.45							
X.X	±0.30	③	Update	08.11.2019	Carson	Approved	08.11.2019	
X.XX	±0.20	②	1.Change the Current Rating from 1.0A to be 1.8A 2.Add the Mating cycle	16.06.2017	Fred			Drawing-No. <b>ASS 4708 CO</b>
X.XXX	±0.10	①	Add the "USB3.0 COMPLIANT "	24.03.2014	Winnie			
DIM	TOL	①	Drawn	14.03.2012	Lucas			Replace
X.°	±5°	①	Id.					
X.X°	±3°		Modification	Date	Name			

H

**ASSMANN**  
WSW/ components

1

2

3

4

5

6

7

SV2729