

TRADE MARK

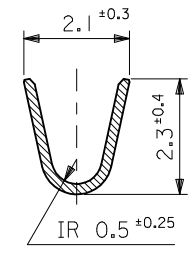

SECT. A-A

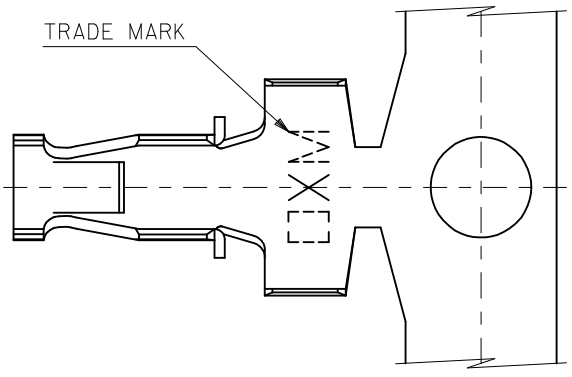
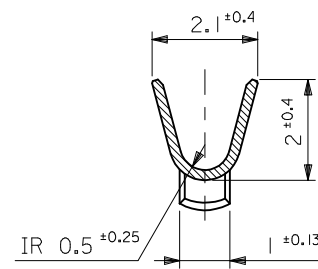

SECT. B-B

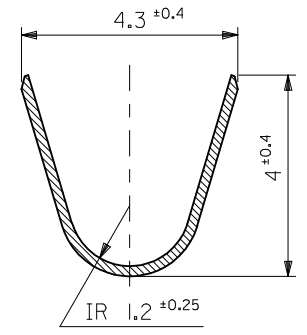

SECT. C-C

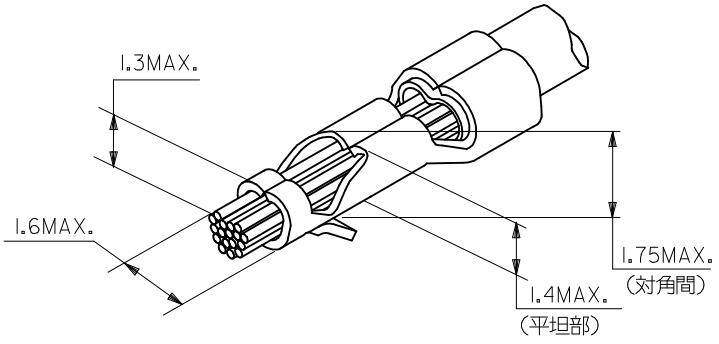
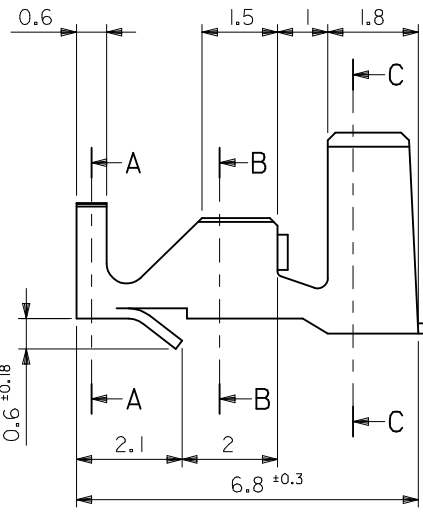

压着外觀図
OUTSIDE VIEW OF CRIMP

NOTES

- 推奨プリント基板孔径: $\phi 1.8^{+0.1}$
RECOMMENDED P.C.B. HOLES: $\phi 1.8^{+0.1}$
- 推奨プリント基板厚: $t1.57^{+0.2}$
RECOMMENDED P.C.B. THICKNESS: $1.57^{+0.2}$
- 材料の厚み: 0.203
MATERIAL THICKNESS: 0.203

| | | | | |
|--|-----------------|----------|------------|----------|
| TIN-LEAD(90-10) 3.8 μ m MIN. OVER NICKEL 1.3 μ m MIN. | PHOSPHOR BRONZE | CHAIN | 39-00-0277 | 5298PBPT |
| TIN 0.9 μ m MIN. REFLOW TREATMENT (PRE-PLATED) | PHOSPHOR BRONZE | CHAIN | 39-00-0230 | 5298PBT |
| TIN 0.9 μ m MIN. OVER COPPER 0.5 μ m MIN. (PRE-PLATED) | BRASS | CHAIN | 08-70-0106 | 5298T |
| PLATING | | MATERIAL | FORM | EDP NO. |
| | | | | ENG. NO. |

| | |
|----------------------|------------------|
| 材料 MATERIAL | SEE TABLE & NOTE |
| 仕上げ FINISH | — |
| 適用電線範囲 WIRE RANGE | AWG #18-22 |
| 被覆外径 INS. RANGE | $\phi 1.7-3.05$ |

| | | | | |
|-------------|-------------------|---------------------------|-----------------------------|-------------------------|
| REVISED | EC NO. J2017-0224 | DRW: NISHIKAWA 2016/10/12 | CHK: K.TAKAHASHI 2016/10/12 | APP: M.SASAO 2016/10/14 |
| DESCRIPTION | | | | |
| REV | | | | |

| | | |
|--|------|--|
| GENERAL TOLERANCES (UNLESS SPECIFIED) | | |
| 0.25 UNDER | ± | |
| 0.25 OVER 0.5 UNDER | ± | |
| 0.5 OVER 1.0 UNDER | ± | |
| 10 OVER 30 UNDER | ±0.2 | |
| 30 OVER | ±0.3 | |
| ANGULAR | ±3 ° | |
| DRAFT WHERE APPLICABLE MUST REMAIN WITHIN DIMENSIONS | | |

| | | | | |
|-----------------|-----------|--------------------------------|--------------|------------------------|
| DIMENSION STYLE | | SCALE | DESIGN UNITS | THIRD ANGLE PROJECTION |
| MM ONLY | | | METRIC | |
| DRAWN BY | DATE | TITLE | | |
| H.HIRAMOTO | '91/09/05 | LOW PROFILE PC BOARD CRIMP PIN | | |
| CHECKED BY | DATE | | | |
| H.HIRAMOTO | '93/07/06 | | | |
| APPROVED BY | DATE | | | |
| M.FUKUSHIMA | '93/07/06 | MATERIAL NO. | | |
| SEE TABLE | | SD-5298-001 | | |

| | | | |
|---|--|--------------|-----------|
| MATERIAL NO. | | DOCUMENT NO. | SHEET NO. |
| SEE TABLE | | SD-5298-001 | 1 OF 1 |
| THIS DRAWING CONTAINS INFORMATION THAT IS PROPRIETARY TO MOLEX ELECTRONIC TECHNOLOGIES, LLC AND SHOULD NOT BE USED WITHOUT WRITTEN PERMISSION | | | |