

May.1.2023 Copyright 2023 HIROSE ELECTRIC CO., LTD. All Rights Reserved.
In case of consideration for using Automotive equipment / device which demand high reliability, kindly contact our sales window correspondents.

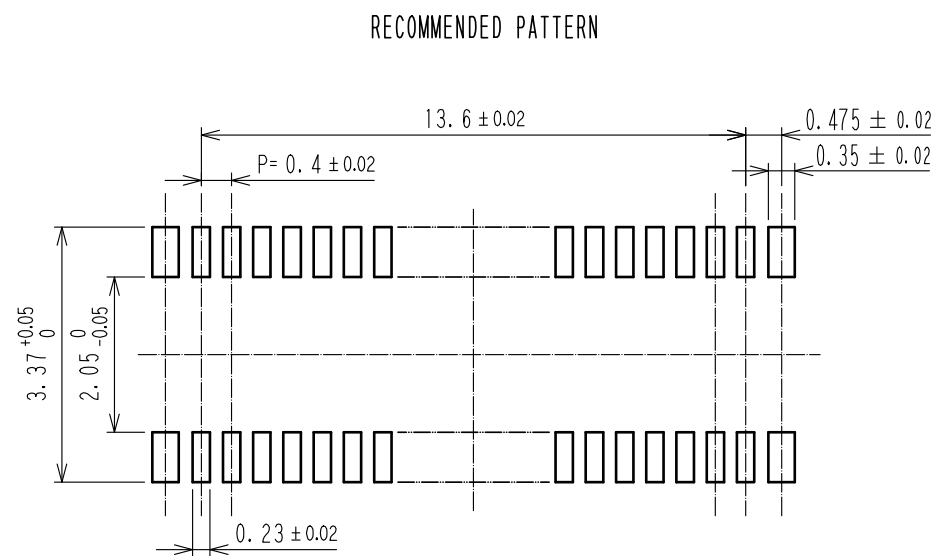

RECOMMENDED METAL MASK THICKNESS : 120 μm
RECOMMENDED METAL MASK OPENING RATIO : 80% FOR LEAD PAD

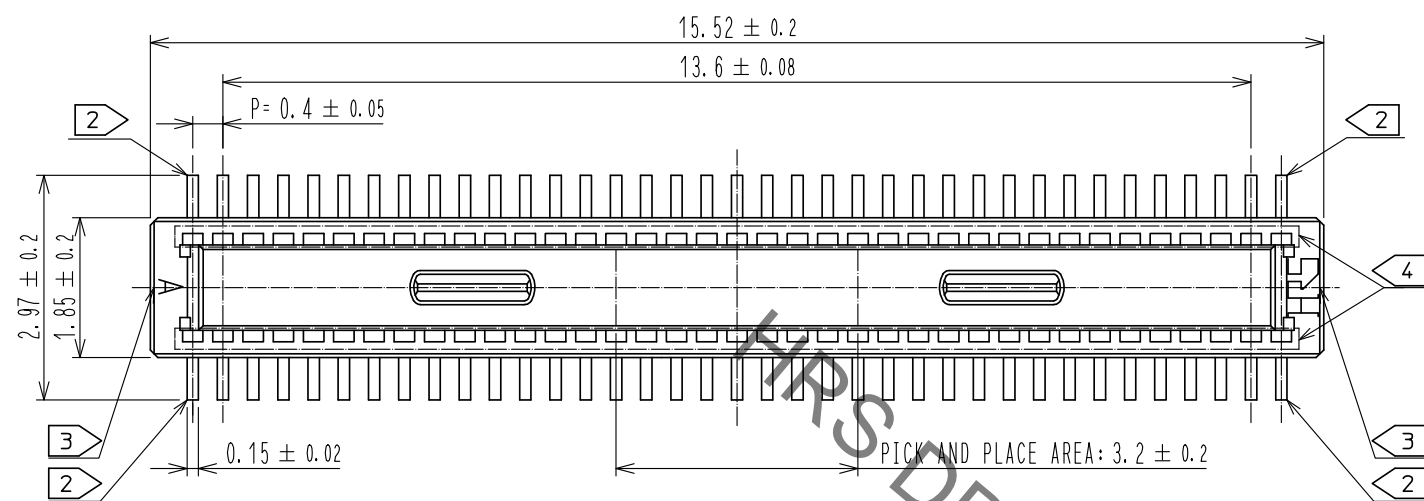
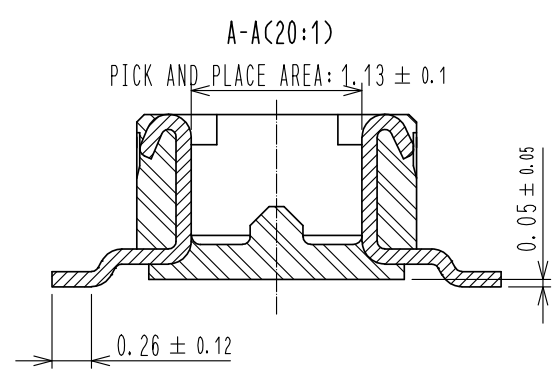
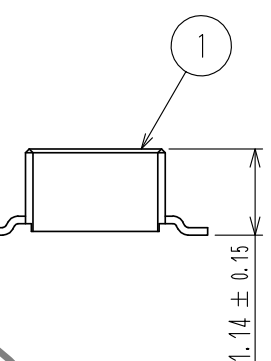
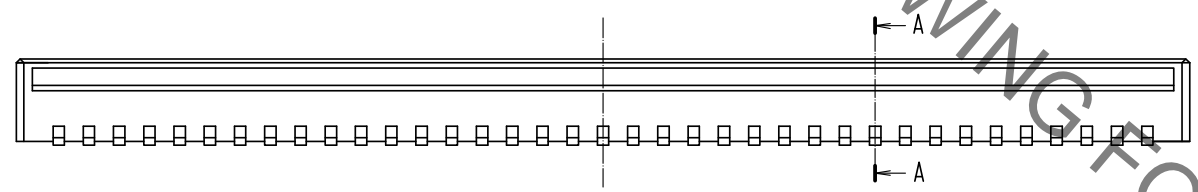

- NOTES)
- 1. ALL LEADS CO-PLANARITY SHALL BE 0.1MAX.
 - 2. EACH ONE CONTACT AT 4 CORNERS SHALL BE USED AS METAL HOLD DOWN.
 - 3. HRS MARK AND CAV NO. IS INDICATED IN APPROXIMAL POSITION SHOWN.
 - 4. THERE IS A POSSIBILITY THAT THE RESIN WILL BE EXPOSED AT THIS AREA, BUT THIS WILL NOT AFFECT THE CONTACT RELIABILITY.

2	PHOSPHOR BRONZE	CONTACT AREA:GOLD 0.05 μm MIN	6	PS	CLEAR, REINFORCEMENT COLLAR		
		SMT LEAD:GOLD 0.05 μm MIN	5	PS	BLACK		
		UNDERPLATING:NICKEL 1 μm MIN	4	POLYESTER	CLEAR, COVER TAPE		
1	LCP	BLACK, UL94V-0	3	PS	CLEAR, EMBOSSED CARRIER TAPE		
NO.	MATERIAL	FINISH . REMARKS	NO.	MATERIAL	FINISH . REMARKS		
UNITS mm		SCALE 10: 1	COUNT 2	DESCRIPTION OF REVISIONS DIS-H-00015059	DESIGNED TY. MORISHITA	CHECKED RT. SHIMIZU	DATE 20220824
HRS HIROSE ELECTRIC CO., LTD.		APPROVED : MO. ISHIDA	20161005	DRAWING NO. EDC-311639-58-01			
		CHECKED : TS. MIYAZAKI	20161005	PART NO. DF40C-70DP-0.4V(58)			
		DESIGNED : SH. HOSODA	20161005	CODE NO. CL0684-4015-2-58			
		DRAWN : SN. NUMAZAKI	20161004				

May.1.2023 Copyright 2023 HIROSE ELECTRIC CO., LTD. All Rights Reserved.
In case of consideration for using Automotive equipment / device which demand high reliability, kindly contact our sales window correspondents.

SCALE (5:1)

STYLE AND DIMENSION OF REEL (FREE)

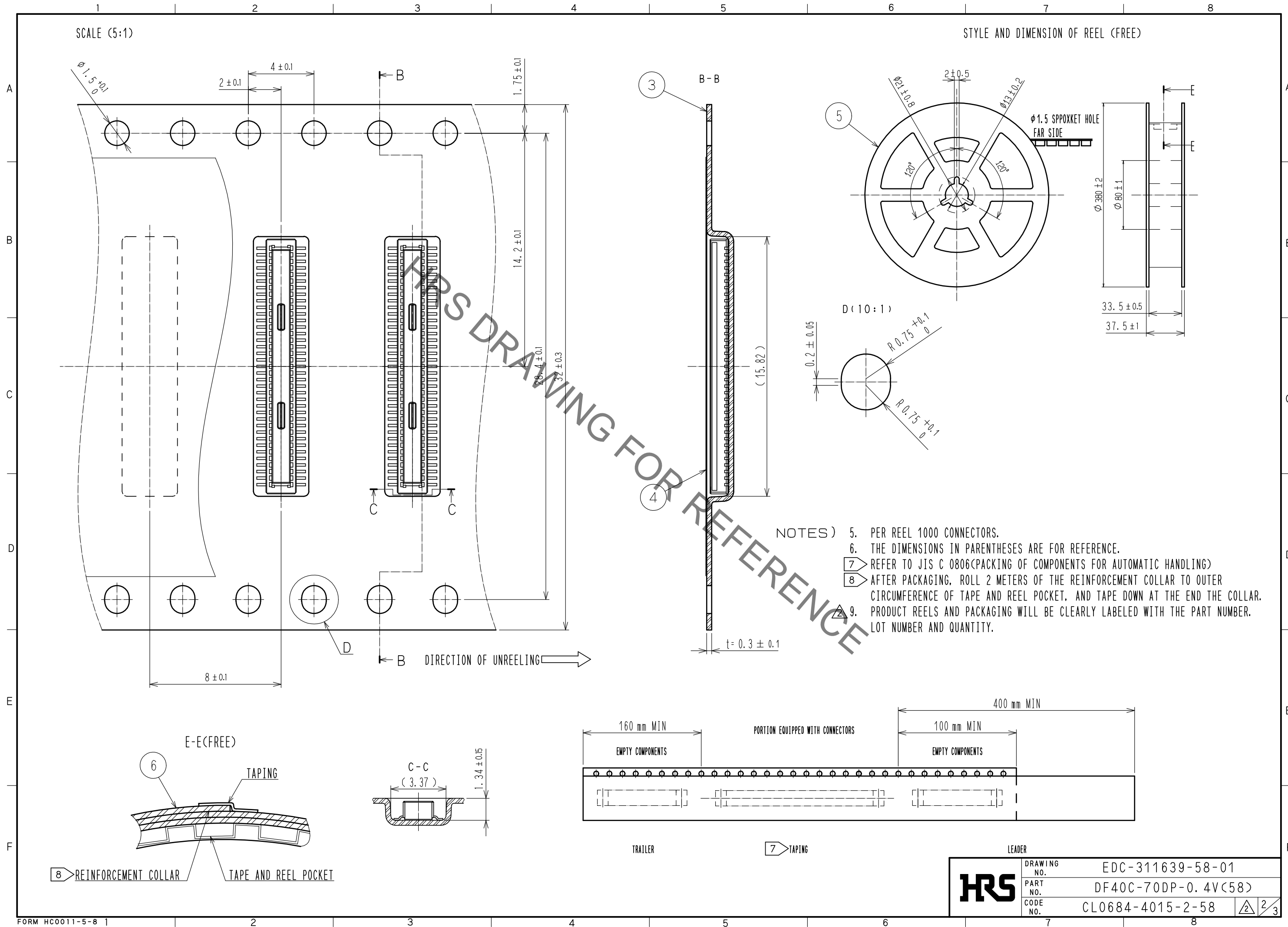

- NOTES)
5. PER REEL 1000 CONNECTORS.
 6. THE DIMENSIONS IN PARENTHESES ARE FOR REFERENCE.
 7. REFER TO JIS C 0806(PACKING OF COMPONENTS FOR AUTOMATIC HANDLING)
 8. AFTER PACKAGING, ROLL 2 METERS OF THE REINFORCEMENT COLLAR TO OUTER CIRCUMFERENCE OF TAPE AND REEL POCKET, AND TAPE DOWN AT THE END THE COLLAR.
 9. PRODUCT REELS AND PACKAGING WILL BE CLEARLY LABELED WITH THE PART NUMBER, LOT NUMBER AND QUANTITY.

HRS	DRAWING NO.	EDC-311639-58-01	2/3
	PART NO.	DF40C-70DP-0.4V(58)	
	CODE NO.	CL0684-4015-2-58	

May.1.2023 Copyright 2023 HIROSE ELECTRIC CO., LTD. All Rights Reserved.
In case of consideration for using Automotive equipment / device which demand high reliability, kindly contact our sales window correspondents.

△10. PLEASE REFER TO THE PRODUCT GUIDELINE ETAD-H1015 FOR DETAIL OF CONNECTOR HANDLING.

THE POSITION BETWEEN THE CONNECTOR AND PAD

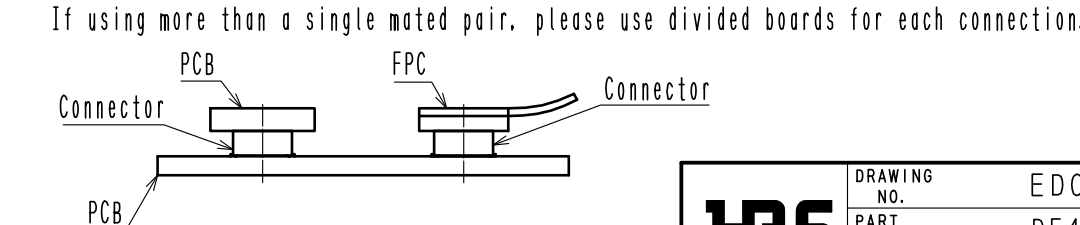
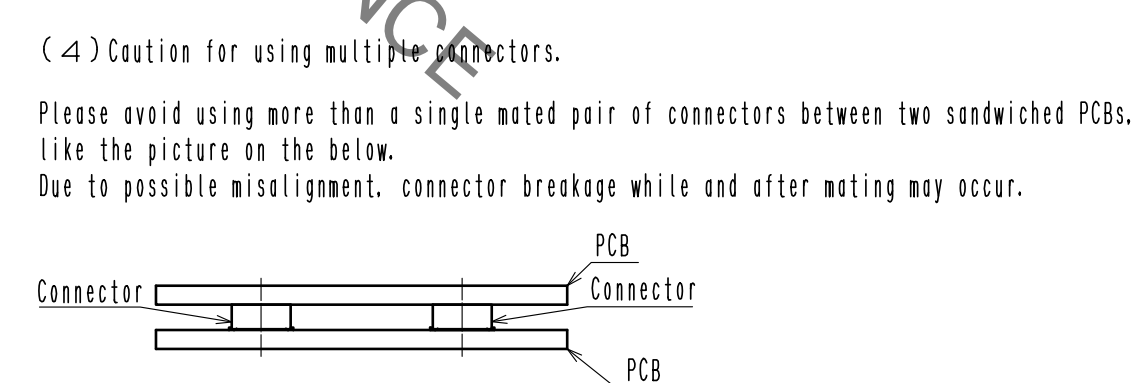
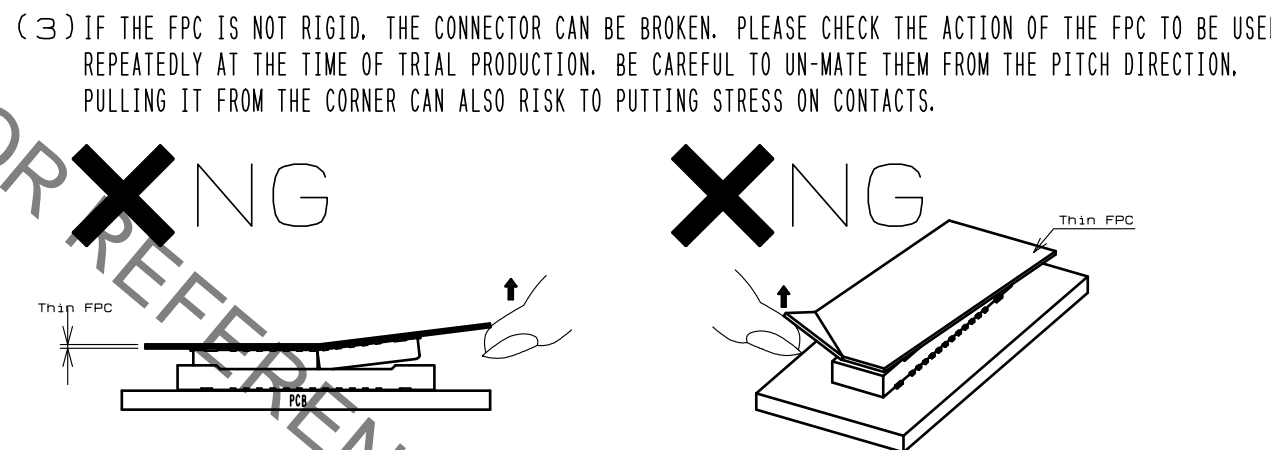
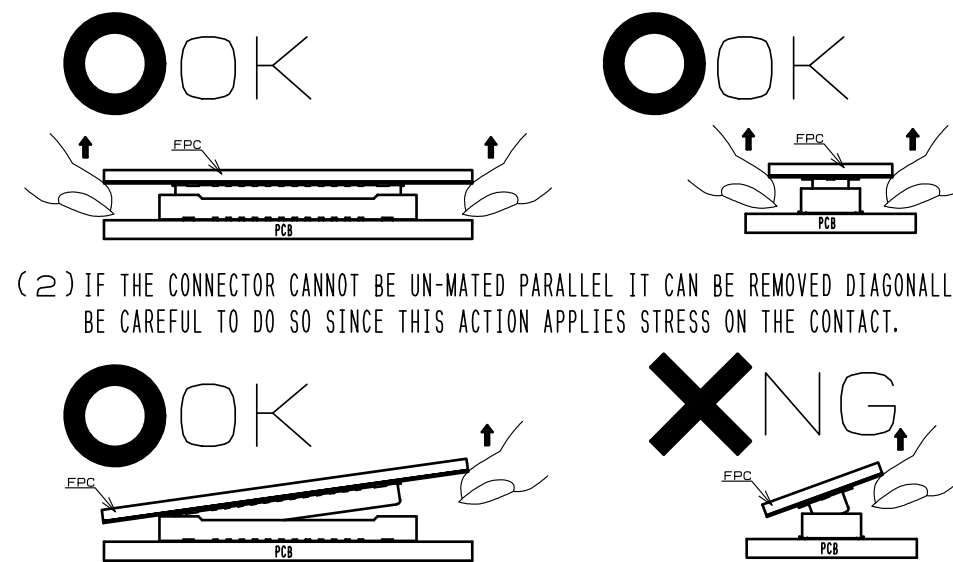
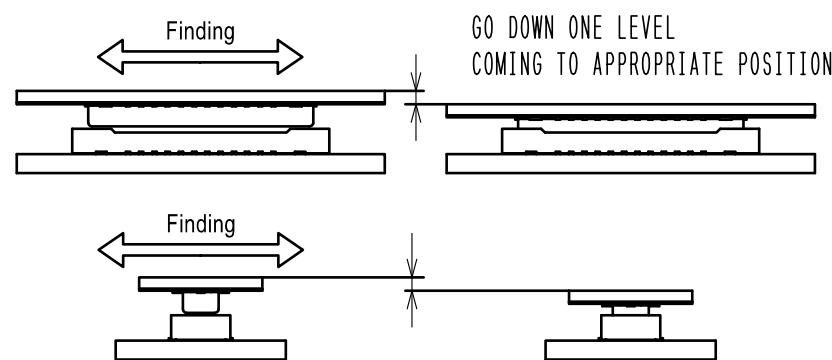
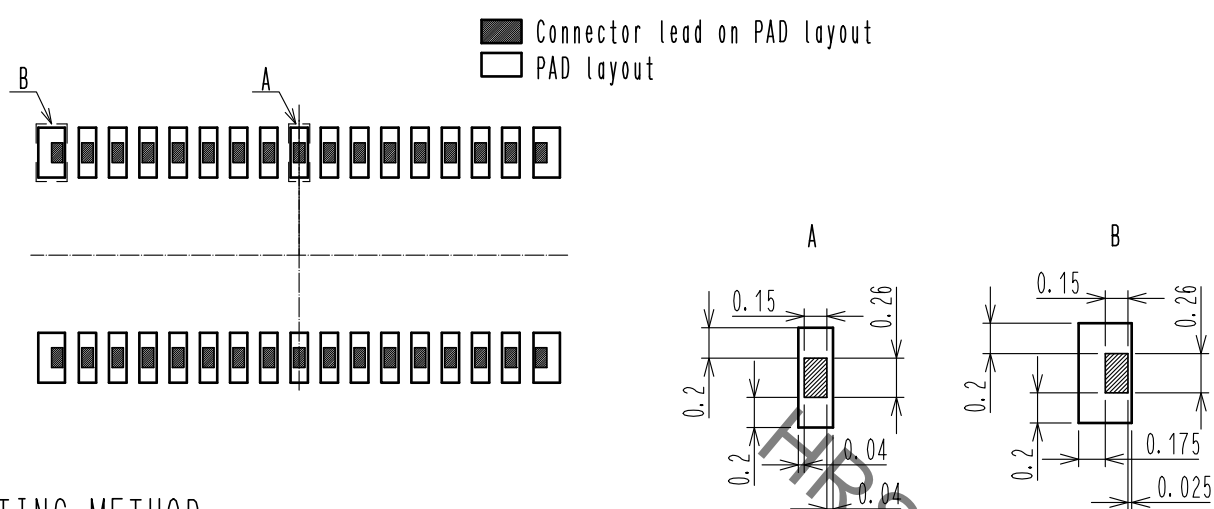

HRS	DRAWING NO.	EDC-311639-58-01
	PART NO.	DF40C-70DP-0.4V(58)
	CODE NO.	CL0684-4015-2-58
		△ 3/3