

5

5



APPROVAL SHEET

Customer Name : _____

Model Name : _____ COOLER _____

Model Name : _____ FHS-A9025S20 _____

Customer Part No : _____

Spec Issue Date : _____ 2013 / 06 / 10 _____

Spec Revision : _____ 06 _____

PLEASE SEND ONE COPY OF THIS SPECIFICATION BACK AFTER YOU
SIGNED APPROVAL FOR PRODUCTION PRE-ARRANGMENT.

Approved By: _____

Date: _____

Approval	Check	Designer
<i>Charles. Chen</i>	<i>Charles. Chen</i>	Skyler.Huang



Delta Electronics Corp.

REV.	Description	Drawn	Checked	Approved	Issue Date
00	ISSUE SPEC	Skyler-Huang 12/29'09	Charles Chen 12/29'09	Alex-Hsia 12/29'09	
01	1. The wire is changed from UL 10368 AWG#22 to UL 10368 AWG#26.	HIKARU.CHEN 06/15'11	Charles Chen 06/15'11	Alex-Hsia 06/15'11	
02	1. Add RoHS Certification.	HIKARU 09/21'11	Charles Chen 09/21'11	Alex-Hsia 09/22'11	
03	1. The HSK is changed from 3346208500 to 3346777600.	HIKARU 11/21'11	Charles Chen 11/21'11	Alex-Hsia 11/22'11	
04	1. Modify the Package spec 2. Change the Fan P/N	Skyler-Huang 08/21'12	Charles Chen 08/21'12	Alex-Hsia 08/21'12	
05	1. Change the Fan P/N 2. Correct thermal resistance 3. Updated the Rohs 4. Modify the cable length to 250mm	Skyler-Huang 05/20'13	Charles Chen 05/20'13	Charles Chen 05/20'13	
06	1. Modify the Package spec 2. Modify the fan label form	Skyler-Huang 06/10'13	Charles Chen 06/10'13	Charles Chen 06/10'13	
Description: SAMPLE REVISION CODE LIST					
Part No.					REV
DELTA MODEL : FHS-A9025S20		TOTAL 75 PAGE			06



Delta Electronics Corp.

CONTENTS

Item	Element Description	Page	Note
1	Specification	5	
2	Print	6	
3	Packing Plan	12	
4	Fan Specification	15	
5	RoHS Certification	26	

1. SPECIFICATION

Characters

Item	Description
Scope	THIS SPECIFICATION DEFINES THE ELECTRICAL AND MECHANICAL CHARACTERISTICS OF THE FAN HEATSINK
Application	INTEL CPU COOLER
Specification	
a: Thermal Resistance	0.37 (°C/W) (REF.)
b: total weight	180 g (REF.)
c: clip force	15.9 kgf (REF.)

BOM

Item	Part Name	Material	Part NO.	Q'TY	Remark
1	FAN	PBT	3622922011	1	
2	HSK	AL A6063-T5	3346777600	1	
3	FASTENER CAP	PC	3470415400	4	
4	FASTENER BASE	PC	3470415500	4	
5	LABEL	PE	3266799500	1	
6	TIM	DOW TC-1996	4021101500	0.15g	



Delta Electronics Corp.

2. PRINT

Assembly Drawing

Parts Drawing

06

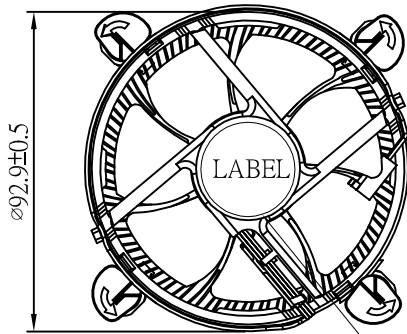

05

MODIFY THE CABLE LENGTH FROM 360MM TO 250 MM

FAN LABEL P/N:3266799500

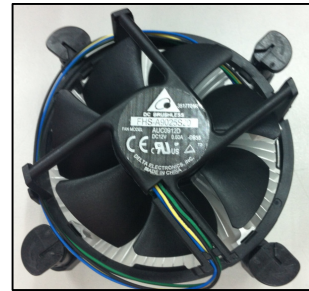
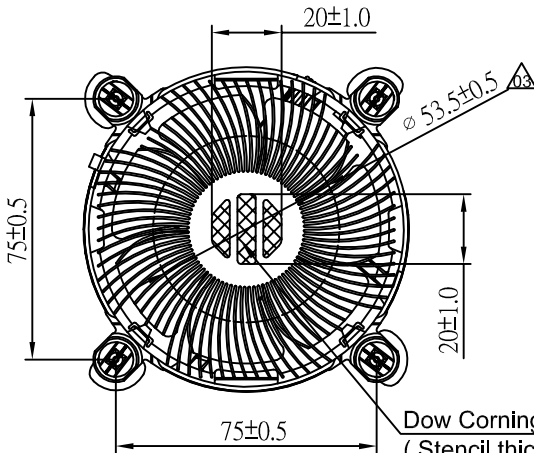
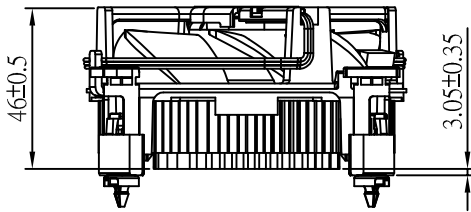
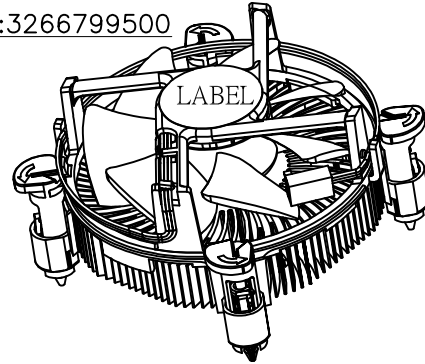

Dow Corning TC-1996 · P/N : 4021101500
(Stencil thickness 0.18TYP · 0.2Max
TIM weight on HSK Must be 140mg±30mg.)

*NOTE : PLEASE ATTENTION FAN LABEL ORIENTATION.

UNIT : mm



台達電子工業股份有限公司
DELTA ELECTRONICS, INC.

DELTA MODEL:
FHS-A9025S20

Drawn:
Skyler Huang

THESE DRAWINGS AND SPECIFICATIONS ARE THE PROPERTY OF DELTA ELECTRONICS, INC. AND SHALL NOT BE REPRODUCED OR USED AS THE BASIS FOR THE MANUFACTURE OR SELL OF APPARATUS OR DEVICES WITHOUT PERMISSION.

CUSTOMER NAME: ---
CUSTOMER P/N: ---

DIMENSIONAL TOLERANCES		HOLES : ±0.05		ANGLES : ±0.5	
()	()	()	()	()	()
<30	±0.25	DECIMALS	UP-100 ±0.2	250-300 ±0.4	UP-600 ±1.5
>30-100	±0.35	X	100-150 ±0.25	300-350 ±0.45	600-900 ±2.4
>100-300	±0.5	X.X	150-200 ±0.3	350-400 ±0.5	900-OVER ±3.1
ABOVE 300	±0.6	X.XX	200-250 ±0.35		



Description: PRODUCTION SPEC.
(PHYSICAL DIMENSION)

A3
SIZE

Part No.
FHS-A9025S20-PD

REV.
06

SCALE --- UNIT --- USED ON COOLER

SHEET 1 OF 2 ISSUE DATE:

06

DATECODE POSITION



DATECODE POSITION
TYPE : WHITE INK

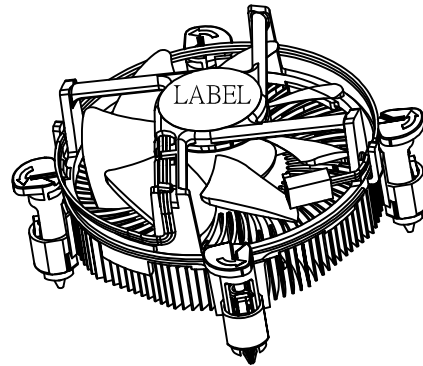

NOTE :

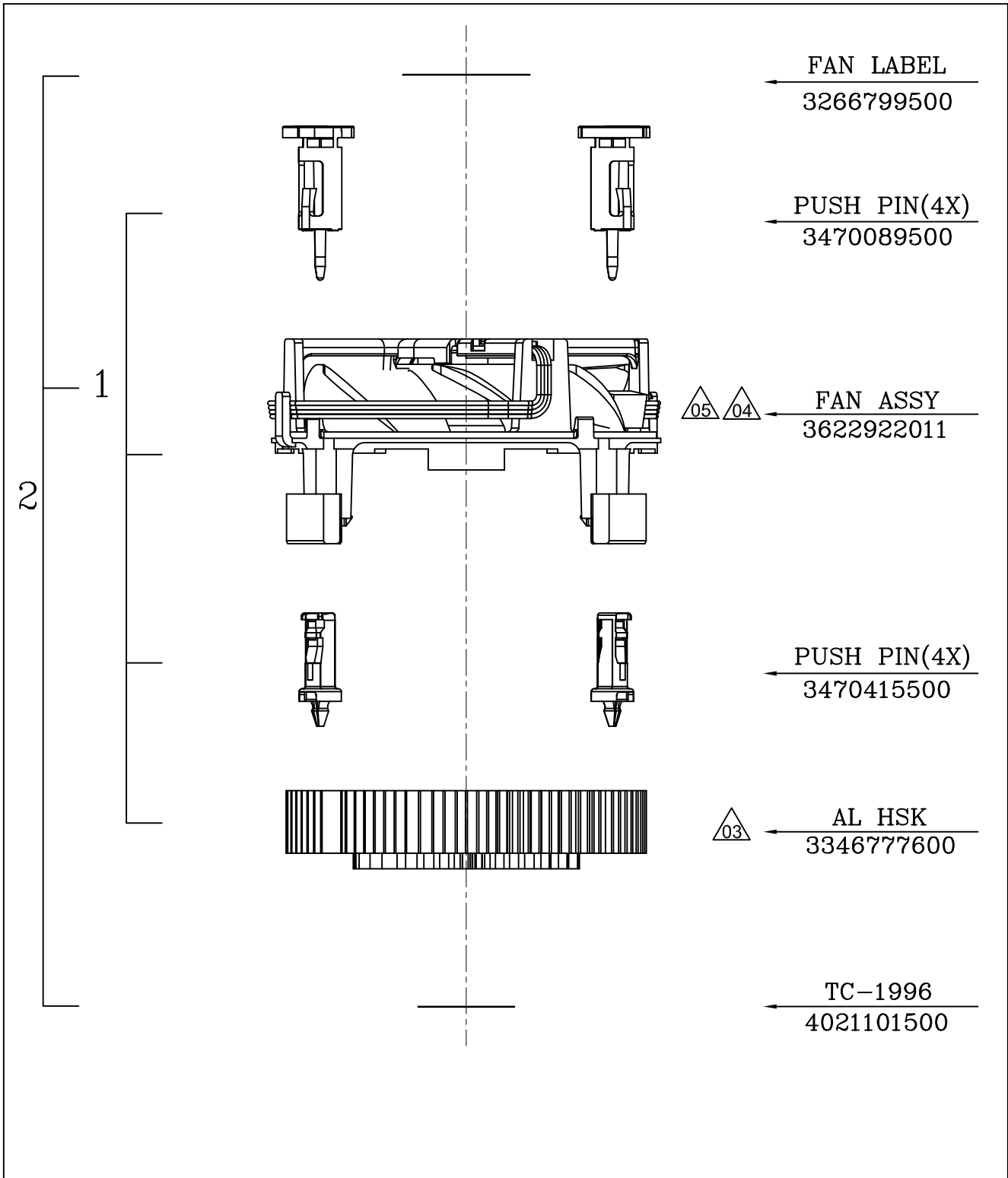

1. DATECODE ON FAN LABEL.
2. PLEASE REFER TO CP10S-00345 WHILE PRINTING DATECODE.

台達電子工業股份有限公司 DELTA ELECTRONICS, INC.	DELTA MODEL: FHS-A9025S20	Drawn: Skyler Huang
	THESE DRAWINGS AND SPECIFICATIONS ARE THE PROPERTY OF DELTA ELECTRONICS, INC. AND SHALL NOT BE REPRODUCED OR USED AS THE BASIS FOR THE MANUFACTURE OR SELL OF APPARATUSES OR DEVICES WITHOUT PERMISSION.	
DIMENSIONAL TOLERANCES () () () HOLES : ±0.05 ANGLES : ±0.5 <30 ±0.25 DECIMALS UP-100 ±0.2 250-300 ±0.4 UP-600 ±1.5 >30-100 ±0.35 X ±0.3 100-150 ±0.25 300-350 ±0.45 600-900 ±2.4 >100-300 ±0.5 X.X ±0.2 150-200 ±0.3 350-400 ±0.5 900-OVER ±3.1 ABOVE 300 ±0.6 X.XX ±0.1 200-250 ±0.35	Description: PRODUCTION SPEC. (PHYSICAL DIMENSION)	Part No. FHS-A9025S20-PD REV. 06
	A3 SIZE	SHEET 2 OF 2 ISSUE DATE:
SCALE --- UNIT --- USED ON COOLER		

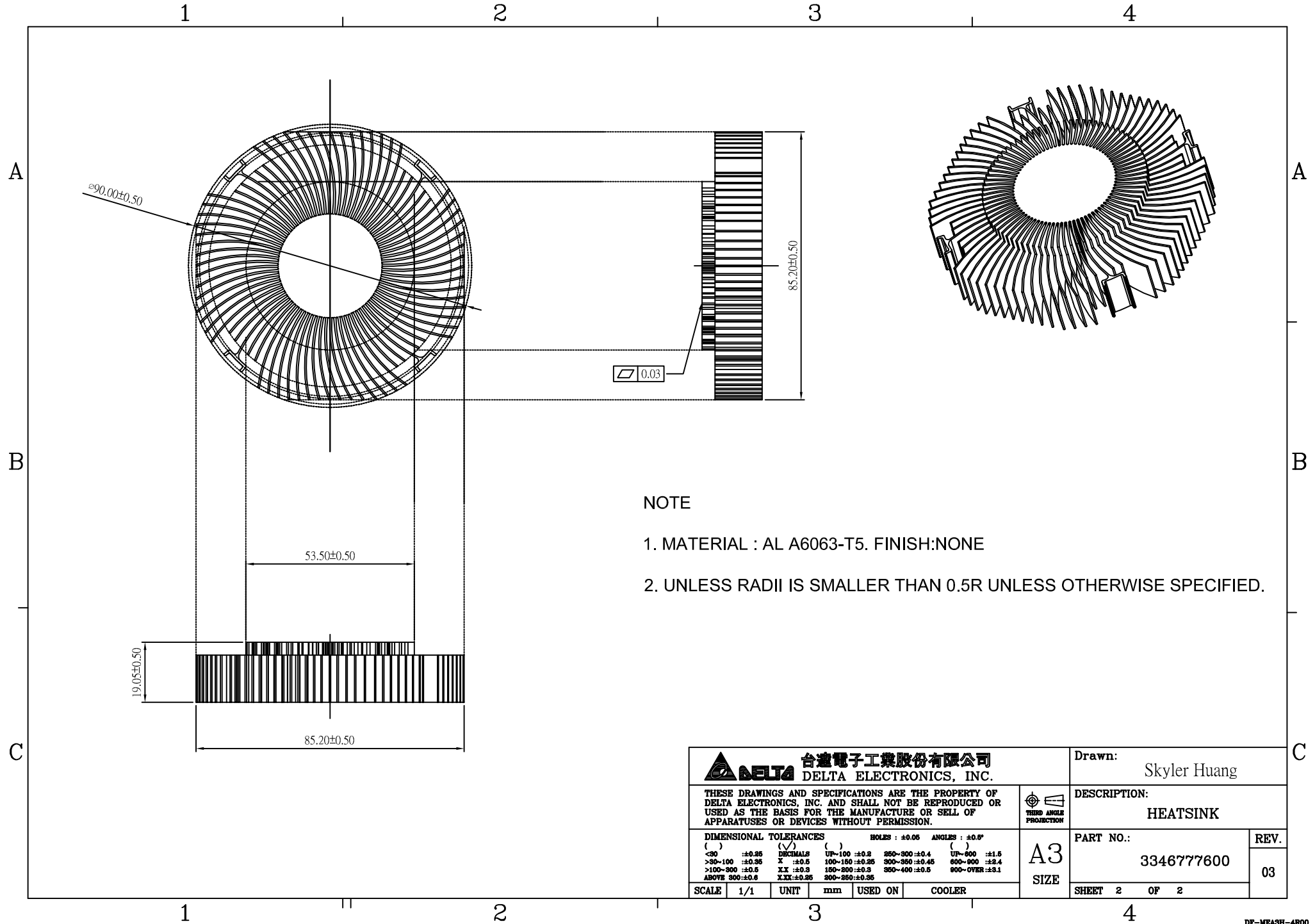

台達電子工業股份有限公司 DELTA ELECTRONICS, INC.	DELTA MODEL: FHS-A9025S20	Drawn: Skyler Huang
	THESE DRAWINGS AND SPECIFICATIONS ARE THE PROPERTY OF DELTA ELECTRONICS, INC. AND SHALL NOT BE REPRODUCED OR USED AS THE BASIS FOR THE MANUFACTURE OR SELL OF APPARATUSES OR DEVICES WITHOUT PERMISSION.	
DIMENSIONAL TOLERANCES () () () <30 ±0.25 DECIMALS UP-100 ±0.2 250-300 ±0.4 UP-600 ±1.5 >30-100 ±0.35 X ±0.3 100-150 ±0.25 300-350 ±0.45 600-900 ±2.4 >100-300 ±0.5 XX ±0.2 150-200 ±0.3 350-400 ±0.5 900-OVER ±3.1 ABOVE 300 ±0.6 X.XX ±0.1 200-250 ±0.35	 THIRD ANGLE PROJECTION	Description: PRODUCTION SPEC. (ASSEMBLY ORDER)
	SCALE --- UNIT --- USED ON COOLER	A4 SIZE
		REV. 05



 台達電子工業股份有限公司 DELTA ELECTRONICS, INC.		Drawn: Skyler Huang	
THESE DRAWINGS AND SPECIFICATIONS ARE THE PROPERTY OF DELTA ELECTRONICS, INC. AND SHALL NOT BE REPRODUCED OR USED AS THE BASIS FOR THE MANUFACTURE OR SELL OF APPARATUS OR DEVICES WITHOUT PERMISSION.		 DESCRIPTION: HEATSINK	
DIMENSIONAL TOLERANCES () ± 0.25 (✓) () () <30 ± 0.25 DECIMALS UP-100 ± 0.3 250-300 ± 0.4 UP-600 ± 1.5 >30-100 ± 0.25 X ± 0.5 100-150 ± 0.25 300-350 ± 0.45 600-900 ± 2.4 >100-300 ± 0.5 XX ± 0.5 150-200 ± 0.5 350-400 ± 0.5 900-OVER ± 3.1 ABOVE 300 ± 0.6 XXX ± 0.25 300-250 ± 0.25		A3 SIZE	
SCALE	1/1	UNIT	mm
USED ON	COOLER	PART NO.: 3346777600	
SHEET 2 OF 2		REV. 03	

1

2

3

4

A

A

B

B

C

C

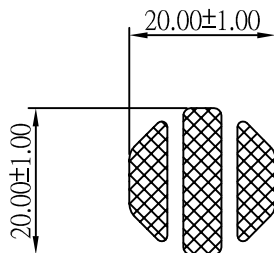

- NOTES: 1. THICKNESS: 0.18mm
 2. VENDOR P/N: DOW CORNING TC-1996
 3. COLOR: GRAY.
 4. THERMAL CONDUCTIVITY: 4.1 W/m-°C
 5. THERMAL CONTACT RESISTANCE: 0.06 °C-cm²/W @40psi
 6. GROSS WEIGHT: 140±30 mg
 7. VENDOR : DOW CORNING
 8. MUST MEET DELTA'S SPEC : 10000-0162

 台達電子工業股份有限公司 DELTA ELECTRONICS, INC.		Drawn: Skyler Huang			
THESE DRAWINGS AND SPECIFICATIONS ARE THE PROPERTY OF DELTA ELECTRONICS, INC. AND SHALL NOT BE REPRODUCED OR USED AS THE BASIS FOR THE MANUFACTURE OR SELL OF APPARATUS OR DEVICES WITHOUT PERMISSION.		DESCRIPTION: THERMAL INTERFACE			
DIMENSIONAL TOLERANCES () : ±0.25 (✓) : ±0.5 () : ±0.25 () : ±0.25 () : ±0.25 <30 : ±0.25 DECIMALS UP-100 : ±0.2 250-300 : ±0.4 UP-600 : ±1.5 >30-100 : ±0.25 X : ±0.5 100-150 : ±0.25 300-350 : ±0.45 600-900 : ±2.4 >100-300 : ±0.5 XX : ±0.8 150-200 : ±0.3 350-400 : ±0.5 900-OVER : ±3.1 ABOVE 300 : ±0.6 XXX : ±0.1 300-350 : ±0.35		PART NO.: 4021101500			
SCALE	1/1	UNIT	mm	USED ON	COOLER
A4 SIZE		REV. 00			
SHEET		1 OF 1			

1

2

3



4



Delta Electronics Corp.

3. PACKING PLAN

Packing Specification

CARTON ILLUSTRATE	SIZE	524(L)*225(w)*475(H)(mm) 	PACKING QUANTITY	6LAYERS/CARTON 
	MATERIAL	3 LAYERS"AB" FLUTE	CARTON WEIGHT	0.62 kg (REF.)

CARTON OUTSIDE ILLUSTRATE

FRONT

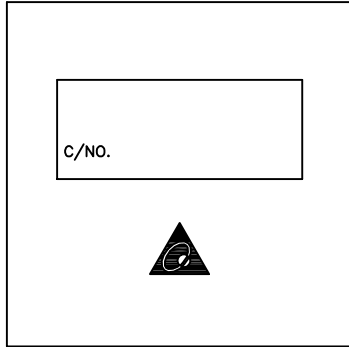

BACK

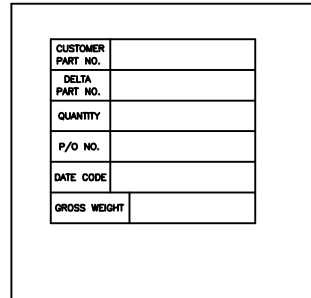

(ONE LABEL PER CARTON)

PET TRAY PACKING ILLUSTRATE	SIZE	94(L)*94(w)*30(H)(mm)	PACKING QUANTITY	1PCS/PET TRAY
	MATERIAL	PET TRAY		
	MATERIAL WEIGHT	6g (REF.)		

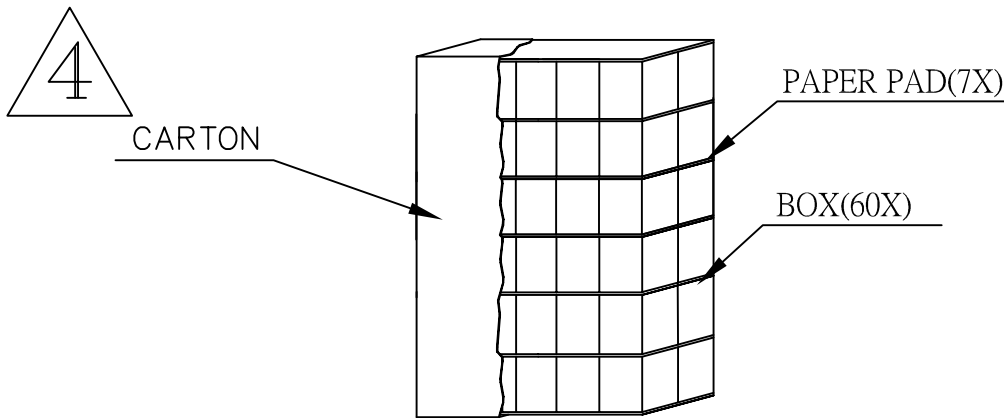

台達電子工業股份有限公司
DELTA ELECTRONICS, INC.

DELTA MODEL:
FHS-A9025S20

Drawn:
Skyler Huang

THESE DRAWINGS AND SPECIFICATIONS ARE THE PROPERTY OF DELTA ELECTRONICS, INC. AND SHALL NOT BE REPRODUCED OR USED AS THE BASIS FOR THE MANUFACTURE OR SELL OF APPARATUS OR DEVICES WITHOUT PERMISSION.

CUSTOMER NAME: -----
CUSTOMER P/N: -----

DIMENSIONAL TOLERANCES		HOLES : ±0.05		ANGLES : ±0.5°	
()	()	()	()	()	()
<30	±0.25	DECIMALS	UP~100 ±0.2	250~300 ±0.4	UP~800 ±1.5
>30~100	±0.35	X	±0.3	100~150 ±0.25	300~350 ±0.45
>100~300	±0.5	XX	±0.2	150~200 ±0.3	350~400 ±0.5
ABOVE 300	±0.6	XXX	±0.1	200~250 ±0.35	900~OVER ±3.1



Description: PRODUCTION SPEC.
(PACKING ASSMEBLY)

A4
SIZE

Part No.
FHS-A9025S20-PA

REV.
06

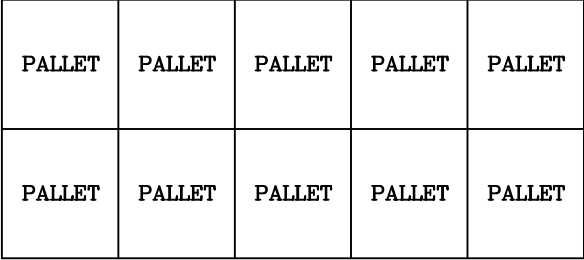
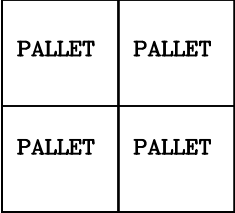

SCALE --- UNIT mm USED ON COOLER

SHEET 1 OF 2 ISSUE DATE:

PART NO.	FHS-A9025S20				
BASIC DATA	QUANTITY/CARTON	60PCS (6 LAYERS/CARTON, 10PCS/LAYER) $\triangle 4$			
	PRODUCTION NET WEIGHT	10.8kg (REF.) $\triangle 4$			
	PRODUCTION GROSS WEIGHT	13.9kg (REF.) $\triangle 4$	$\triangle 6$		
20(ft)CONTAINER ILLUSTRATE	SIZE	5.889(L)*2.352(w)*2.386(H)m		PACKING QUANTITY	20PALLET/CONTAINER
	CONTAINER	STEEL			
CONTAINER FORM					
CONTAINER LOADING MATHOD					
					
TOP VIEW				FRONT VIEW	
				$\triangle 6$	

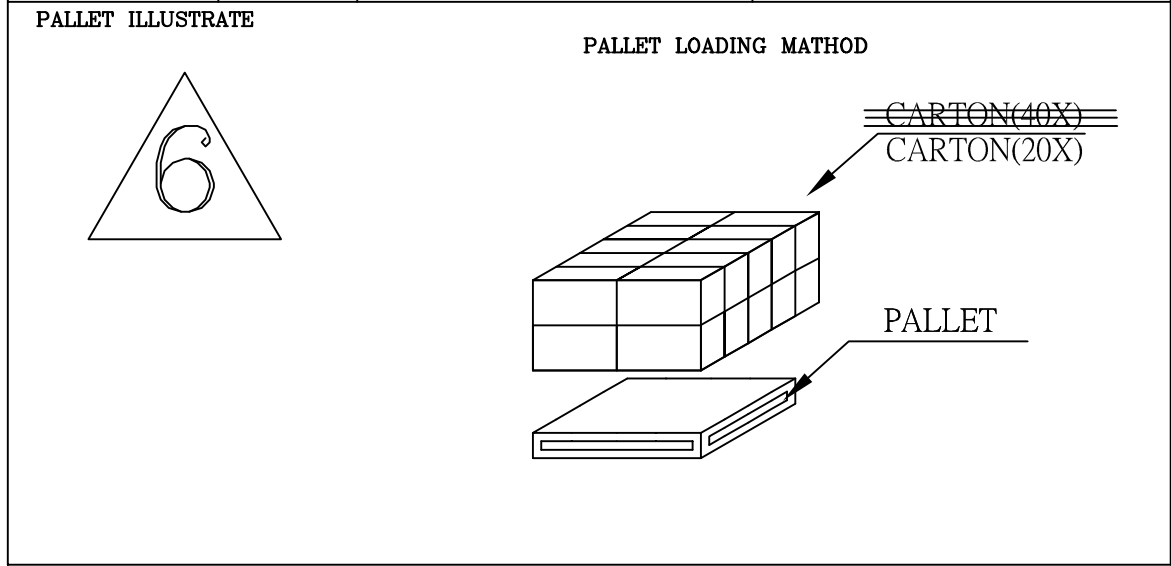
PALLET LOADING ILLUSTRATE	SIZE	117(L)*107(w)*13(H)cm	PACKING QUANTITY	20 CARTONS/PALLET
	PALLET	WOOD		



 台達電子工業股份有限公司 DELTA ELECTRONICS, INC.	DELTA MODEL:	FHS-A9025S20		Drawn:	Skyler Huang
	THESE DRAWINGS AND SPECIFICATIONS ARE THE PROPERTY OF DELTA ELECTRONICS, INC. AND SHALL NOT BE REPRODUCED OR USED AS THE BASIS FOR THE MANUFACTURE OR SELL OF APPARATUSES OR DEVICES WITHOUT PERMISSION.	CUSTOMER NAME:	-----		
	CUSTOMER P/N:	-----			
DIMENSIONAL TOLERANCES () () () HOLES : ± 0.05 ANGLES : $\pm 0.5^\circ$ <30 ± 0.25 DECIMALS UP~100 ± 0.2 250~300 ± 0.4 UP~800 ± 1.5 >30~100 ± 0.35 X ± 0.3 100~150 ± 0.25 300~350 ± 0.45 600~900 ± 2.4 >100~300 ± 0.5 XX ± 0.2 150~200 ± 0.3 350~400 ± 0.5 900~OVER ± 3.1 ABOVE 300 ± 0.6 XXX ± 0.1 200~250 ± 0.35	 Description: PRODUCTION SPEC. (PACKING ASSMEBLY)	Part No.		REV.	
SCALE --- UNIT mm USED ON COOLER	A4	FHS-A9025S20-PA		06	
	SIZE	SHEET 2 OF 2	ISSUE DATE:		



Delta Electronics Corp.

4. FAN

Fan Specification



SPECIFICATION FOR APPROVAL

Customer T M P B U

Description DC FAN

Part No. _____ REV. _____

Delta Model No. AUC0912D-DB55 REV. 00

Sample Issue No. _____

Sample Issue Date FEB.21.2013

PLEASE SEND ONE COPY OF THIS SPECIFICATION BACK
AFTER YOU SIGNED APPROVAL FOR PRODUCTION PRE-
ARRANGMENT.

APPROVED BY: _____

DATE : _____

DELTA ELECTRONICS, INC.
TAOYUAN PLANT
252, SHANG YING ROAD, KUEI SAN INDUSTRIAL ZONE TAOYUAN
SHIEN, TAIWAN, R.O.C.
TEL:886-(0)3-3591968
FAX:886-(0)3-3591991

DELTA ELECTRONICS, INC.
 252, SHANG YING ROAD, KUEI SAN
 TAOYUAN HSIEN 333, TAIWAN, R. O. C.

TEL : 886-(0)3-3591968
 FAX : 886-(0)3-3591991

SPECIFICATION FOR APPROVAL

Customer: TMPBU

 Description: DC FAN

 Customer P/N: REV:

 Delta Model NO.: AUC0912D-DB55 Delta Safety Model NO.: AUC0912D-8L2V

 Sample Rev: 00 Issue NO:

 Sample Issue Date: FEB.21.2013 Quantity:

1. SCOPE:

THIS SPECIFICATION DEFINES THE ELECTRICAL AND MECHANICAL CHARACTERISTICS OF THE DC BRUSHLESS AXIAL FLOW FAN. THE FAN MOTOR IS WITH SINGLE PHASES AND FOUR POLES.

2. CHARACTERS:

ITEM	DESCRIPTION	
SENSOR TEMPERATURE	30°C	40°C
RATED VOLTAGE	12.0 VDC	
OPERATION VOLTAGE	10.8 - 13.2 VDC	
START UP CURRENT	MAX. 0.60A	MAX. 0.75A
INPUT CURRENT	0.07 (MAX. 0.14) A (CURRENT ON SAFETY LABEL 0.60A)	0.16 (MAX. 0.60) A (CURRENT ON SAFETY LABEL 0.60A)
INPUT POWER	0.84 (MAX. 1.68) W	1.68 (MAX. 7.20) W
SPEED (FAN ONLY)	2050±10% R.P.M.	3200±10% R.P.M.
SPEED (FAN ON SINK)	2000±10% R.P.M.	3150±10% R.P.M.
MAX. AIR FLOW (FAN ONLY) (AT ZERO STATIC PRESSURE)	0.537 (MIN. 0.483) M ³ /MIN. 18.96 (MIN. 17.06) CFM	0.914 (MIN. 0.823) M ³ /MIN. 32.29 (MIN. 29.06) CFM
MAX. AIR PRESSURE (FAN ONLY) (AT ZERO AIRFLOW)	1.53 (MIN. 1.24) mmH ₂ O 0.060 (MIN. 0.049) inchH ₂ O	3.61 (MIN. 2.92) mmH ₂ O 0.142 (MIN. 0.115) inchH ₂ O
ACOUSTICAL NOISE(ON SINK AVG.)	26.0 (MAX. 30.0) dB-A	36.0 (MAX. 40.0) dB-A
INSULATION TYPE	UL: CLASS A	

(continued)

PART NO:

DELTA MODEL: AUC0912D-DB55

INSULATION STRENGTH	10 MEG OHM MIN. AT 500 VDC (BETWEEN FRAME AND (+) TERMINAL)
DIELECTRIC STRENGTH	5 mA MAX. AT 500 VAC 50/60 Hz ONE MINUTE, (BETWEEN FRAME AND (+) TERMINAL)
EXTERNAL COVER	OPEN TYPE
LIFE EXPECTANCE (AT LABEL VOLTAGE)	80,000 HOURS CONTINUOUS OPERATION AT 45 °C WITH 15 ~ 65 %RH.
ROTATION	CLOCKWISE VIEW FROM NAME PLATE SIDE
OVER CURRENT SHUT DOWN	THE CURRENT WILL SHUT DOWN WHEN LOCKING ROTOR
LEAD WIRE	UL 10368 -F- AWG #26 BLACK WIRE:NEGATIVE(-) YELLOW WIRE:POSITIVE(+) GREEN WIRE:TACHOMETER OUTPUT (F00) BLUE WIRE:SPEED CONTROL (PWM)

- NOTES: 1. ALL READINGS ARE MEASURED AFTER STABLY WARMING UP THROUGH 10 MINUTES.
2. STANDARD AIR PROPERTY IS AIR AT (Td) 25°C TEMPERATURE, (RH) 65% RELATIVE HUMIDITY, AND (Pb) 760 mmHg BAROMETRIC PRESSURE.
3. THE VALUES WRITTEN IN PARENS , (), ARE LIMITED SPEC.
4. ACOUSTICAL NOISE MEASURING CONDITION:

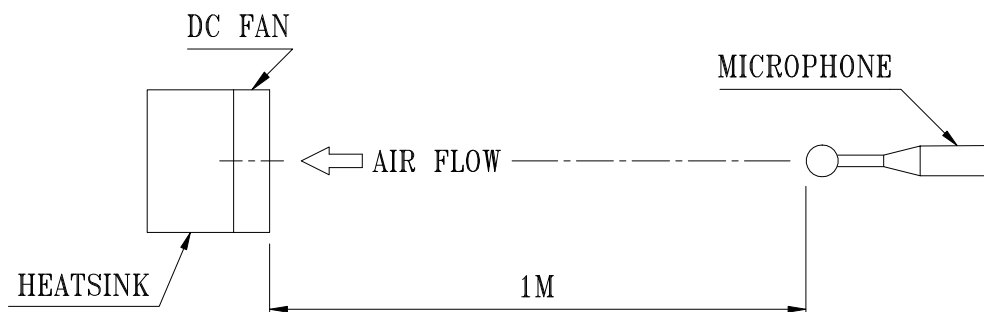

NOISE IS MEASURED AT RATED VOLTAGE IN FREE AIR IN ANECHOIC CHAMBER WITH B & K SOUND LEVEL METER WITH MICROPHONE AT A DISTANCE OF ONE METER FROM THE FAN INTAKE.

PART NO:

DELTA MODEL: AUC0912D-DB55

3. MECHANICAL:

- 3-1. DIMENSIONS ----- SEE DIMENSIONS DRAWING
- 3-2. FRAME ----- PLASTIC UL: 94V-0
(THE HALOGEN SUBSTANCE CONTENT IS LESS THAN 1500 PPM FOR USING EDX ...ETC)
- 3-3. IMPELLER ----- PLASTIC UL: 94V-0
(THE HALOGEN SUBSTANCE CONTENT IS LESS THAN 1500 PPM FOR USING EDX ...ETC)
- 3-4. BEARING SYSTEM ----- SUPERFLO BEARING
- 3-5. WEIGHT ----- 82 GRAMS

4. ENVIRONMENTAL:

- 4-1. OPERATING TEMPERATURE ----- -10 TO +70 DEGREE C
- 4-2. STORAGE TEMPERATURE ----- -35 TO +80 DEGREE C
- 4-3. OPERATING HUMIDITY --- 85% RELATIVE HUMIDITY WITH 55 DEGREE C
- 4-4. STORAGE HUMIDITY ----- 5 TO 95 % RH

5. PROTECTION:

- 5-1. LOCKED ROTOR PROTECTION
IMPEDANCE OF MOTOR WINDING PROTECTS MOTOR FROM FIRE IN 96 HOURS OF LOCKED ROTOR CONDITION AT THE RATED VOLTAGE.
- 5-2. POLARITY PROTECTION
BE CAPABLE OF WITHSTANDING IF REVERSE CONNECTION FOR POSITIVE AND NEGATIVE LEADS.

6. RE OZONE DEPLETING SUBSTANCES:

- 6-1. NO CONTAINING PBBs, PBBOs, CFCs, PBBEs, PBDPEs AND HCFCs.

7. PRODUCTION LOCATION

- 7-1. PRODUCTS WILL BE PRODUCED IN CHINA OR THAILAND .

PART NO:

DELTA MODEL: AUC0912D-DB55

8. P & Q CURVE:
PWM 100% DUTY CYCLE

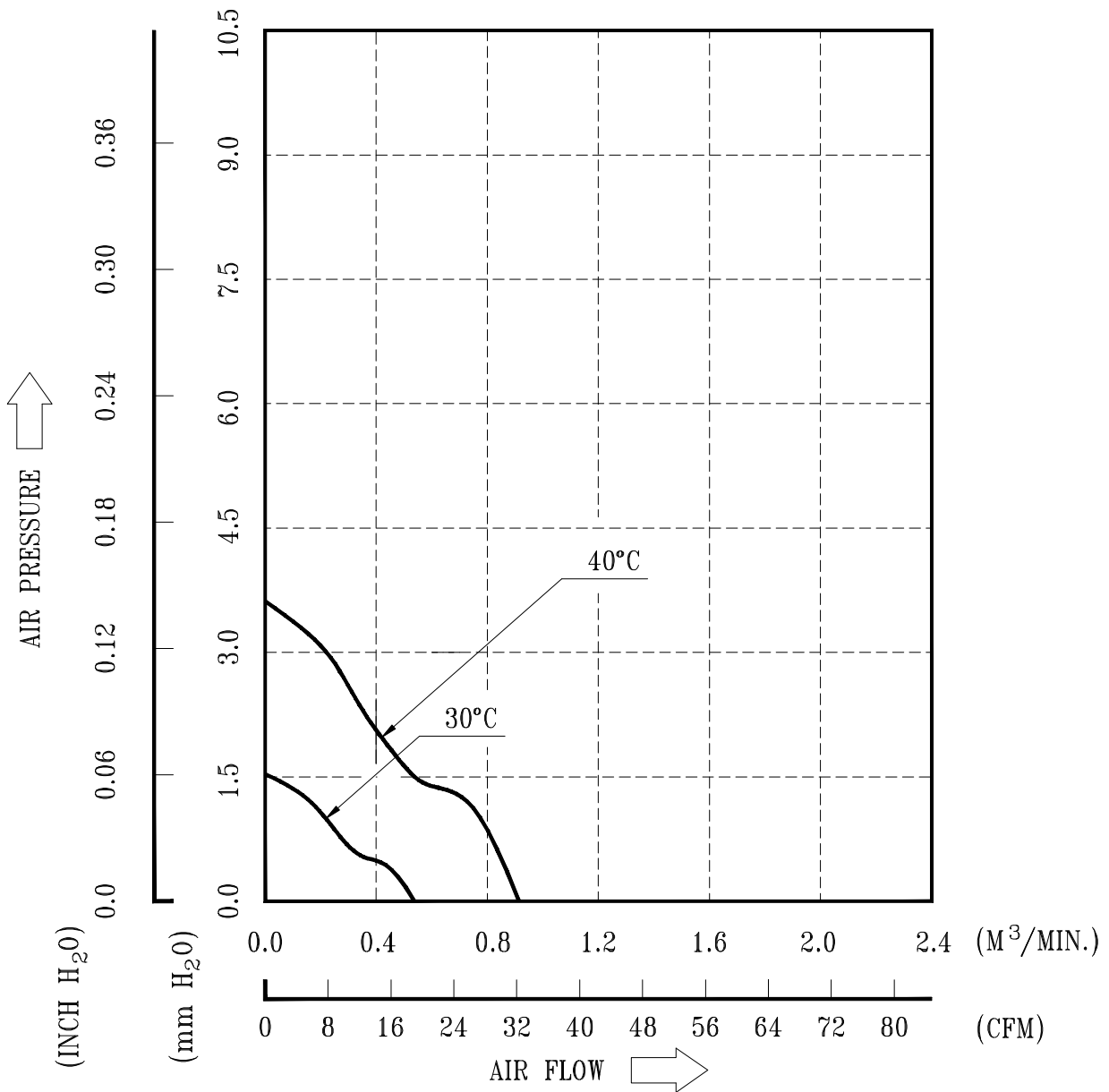

* TEST CONDITION: INPUT VOLTAGE ----- OPERATION VOLTAGE
TEMPERATURE ----- ROOM TEMPERATURE
HUMIDITY ----- 65%RH

PART NO:

DELTA MODEL: AUC0912D-DB55

9. DIMENSION DRAWING:

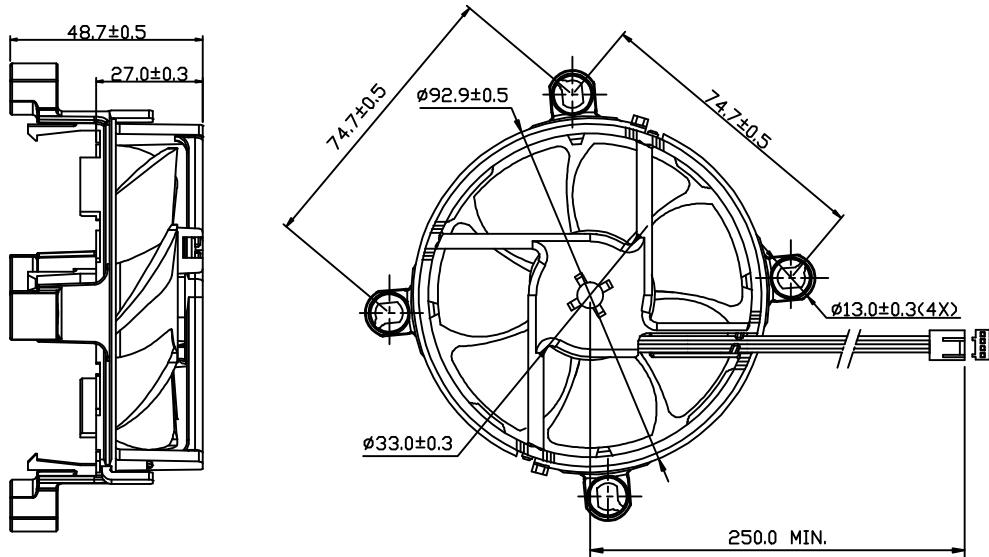

UNIT: MM

- NOTE : 1. LEAD WIRE: UL 10368 -F- AWG #26
PIN 1 : BLACK WIRE: NEGATIVE(-)
PIN 2 : YELLOW WIRE: POSITIVE(+)
PIN 3 : GREEN WIRE: TACHOMETER OUTPUT (F00)
PIN 4 : BLUE WIRE: SPEED CONTROL (PWM)
2. HOUSING : MOLEX 47054-1000 OR EQUIVALENT
3. TERMINAL : MOLEX 2759T 08-50-0113 OR EQUIVALENT
4. THIS PRODUCT IS RoHS COMPLIANT
5. DELTA'S RESTRICTIONS ON HALOGEN APPLY ONLY TO BROMINATED AND CHLORINATED COMPOUNDS. NO OTHER HALOGEN IS RESTRICTED. SUBSTANCES RESTRICTIONS FOR HALOGEN-FREE(INCLUDE FAN PLASTIC PARTS, PWB BOARD, IC, ELECTRICAL MATERIALS & CABLE ASSY),
a. BROMINE(Br) ≤ 900 PPM.
b. CHLORINE(Cl) ≤ 900 PPM.
c. (Br) + (Cl) ≤ 1500 PPM.

PART NO:

DELTA MODEL: AUC0912D-DB55

10. FREQUENCY GENERATOR (FG) SIGNAL:

10-1. OUTPUT CIRCUIT - OPEN DRAIN MODE:

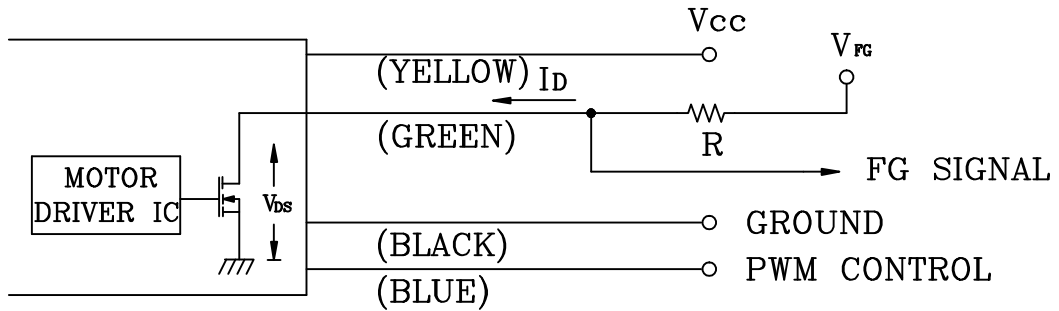

CAUTION: THE FG SIGNAL LEAD WIRE MUST BE KEPT AWAY FROM "+" LEAD WIRE & "-" LEAD WIRE.

10-2. SPECIFICATION:

V_{DS} (LINEAR)=0.5V MAX.

V_{FG} =5.0V TYP. (V_{CC} MAX.)

I_D =5mA MAX.

$R \geq V_{FG} / I_D$

10-3. FREQUENCY GENERATOR WAVEFORM:

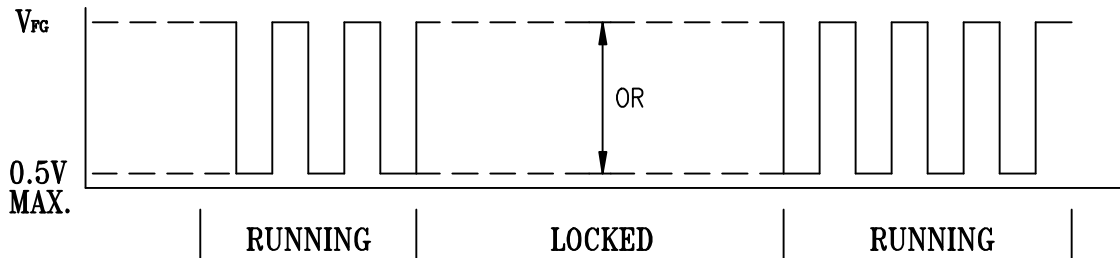

FAN RUNNING FOR 4 POLES

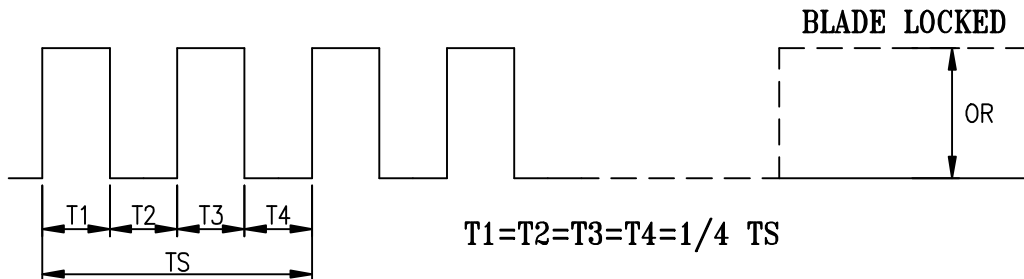

$N=R.P.M$

$TS=60/N(SEC)$

*VOLTAGE LEVEL AFTER BLADE LOCKED

*4 POLES

A00

PART NO:

DELTA MODEL: AUC0912D-DB55

11. PWM CONTROL FUNCTION:(FAN ON SINK)

11-1 SIGNAL DESCRIPTION:

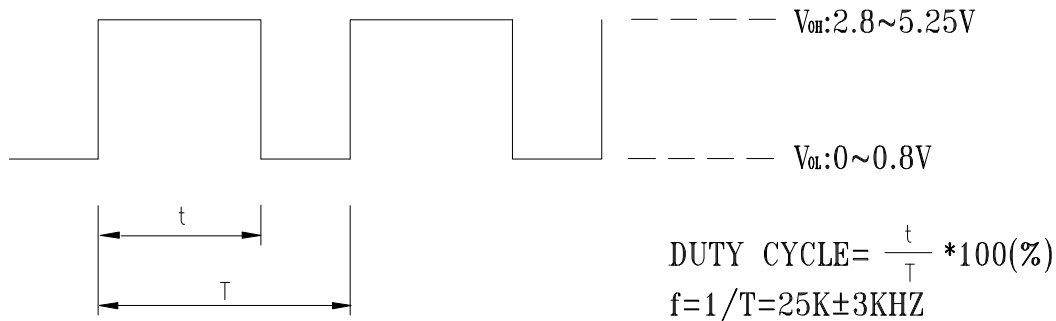

- AT 25K HZ 30% DUTY CYCLE ,THE FAN WILL BE ABLE TO START FROM A DEAD STOP .

11-2 SPEED CONTROL

TEST CONDITION : INPUT VCC=12V PWM FREQUENCY=25KHZ

11-2-1 TEMPERATURE CONTROL

BELOW 30 DEGREE C,THE FAN SPEED IS 2000RPM.

ABOVE 40 DEGREE C,THE FAN SPEED IS 3150RPM.

BETWEEN 30~40 DEGREE C,THE FAN SPEED IS 2000RPM~3150RPM.

11-2-2 PWM CONTROL

BELOW 30 DEGREE C

BETWEEN 0%~20% TO 100% DUTY CYCLE,THE FAN SPEED IS 1000RPM TO 2000RPM.

ABOVE 40 DEGREE C

BETWEEN 0%~20% TO 100% DUTY CYCLE,THE FAN SPEED IS 1000RPM TO 3150RPM.

TEMPERATURE (°C)	DUTY CYCLE (%)	SPEED (R.P.M.)
30	0~20	1000±200
30	100	2000±10%
40	0~20	1000±200
40	100	3150±10%

- IF THE CONTROL SIGNAL IS DISCONNECT THE FAN WILL GO TO TEMPERATURE CONTROL SPEED.

PART NO:

DELTA MODEL: AUC0912D-DB55

12. PWM CONTROL FUNCTION:(FAN ONLY)

12-1 SIGNAL DESCRIPTION:

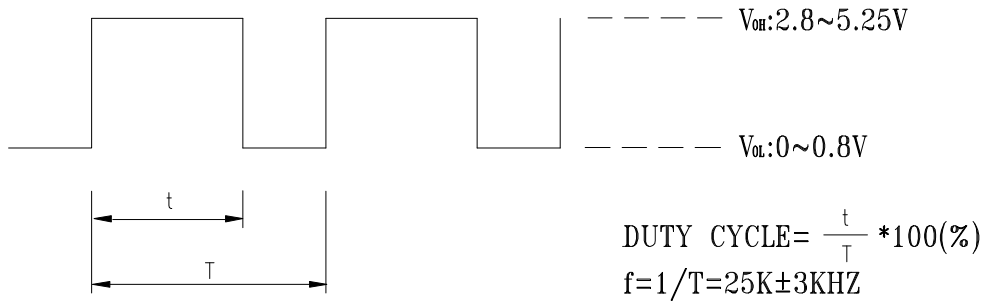

- AT 25K HZ 30% DUTY CYCLE ,THE FAN WILL BE ABLE TO START FROM A DEAD STOP .

12-2 SPEED CONTROL

TEST CONDITION : INPUT VCC=12V PWM FREQUENCY=25KHZ

12-2-1 TEMPERATURE CONTROL

BELOW 30 DEGREE C,THE FAN SPEED IS 2050RPM.

ABOVE 40 DEGREE C,THE FAN SPEED IS 3200RPM.

BETWEEN 30~40 DEGREE C,THE FAN SPEED IS 2050RPM~3200RPM.

12-2-2 PWM CONTROL

BELOW 30 DEGREE C

BETWEEN 0%~20% TO 100% DUTY CYCLE,THE FAN SPEED IS 1000RPM TO 2050RPM.

ABOVE 40 DEGREE C

BETWEEN 0%~20% TO 100% DUTY CYCLE,THE FAN SPEED IS 1000RPM TO 3200RPM.

TEMPERATURE (°C)	DUTY CYCLE (%)	SPEED (R.P.M.)
30	0~20	1000±200
30	100	2050±10%
40	0~20	1000±200
40	100	3200±10%

- IF THE CONTROL SIGNAL IS DISCONNECT THE FAN WILL GO TO TEMPERATURE CONTROL SPEED.

13. PWM CONTROL LEAD WIRE INPUT IMPEDANCE:

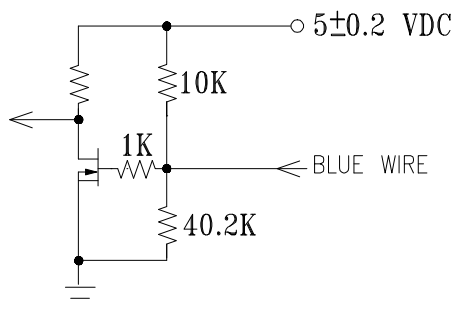



Application Notice

- 1. Delta will not guarantee the performance of the products if the application condition falls outside the parameters set forth in the specification.**
- 2. A written request should be submitted to Delta prior to approval if deviation from this specification is required.**
- 3. Please exercise caution when handling fans. Damage may be caused when pressure is applied to the impeller, if the fans are handled by the lead wires, or if the fan was hard-dropped to the production floor.**
- 4. Except as pertains to some special designs, there is no guarantee that the products will be free from any such safety problems or failures as caused by the introduction of powder, droplets of water or encroachment of insect into the hub.**
- 5. The above-mentioned conditions are representative of some unique examples and viewed as the first point of reference prior to all other information.**
- 6. It is very important to establish the correct polarity before connecting the fan to the power source. Positive (+) and Negative (-). Damage may be caused to the fans if connection is with reverse polarity, if there is no foolproof method to protect against such error specifically mentioned in this spec.**
- 7. Delta fans without special protection are not suitable where any corrosive fluids are introduced to their environment.**
- 8. Please ensure all fans are stored according to the storage temperature limits specified. Do not store fans in a high humidity environment. We highly recommend performance testing is conducted before shipping, if the fans have been stored over 6 months.**
- 9. Not all fans are provided with the Lock Rotor Protection feature. If you impair the rotation of the impeller for the fans that do not have this function, the performance of those fans will lead to failure.**
- 10. Please be cautious when mounting the fan. Incorrect mounting of fans may cause excess resonance, vibration and subsequent noise.**
- 11. It is important to consider safety when testing the fans. A suitable fan guard should be fitted to the fan to guard against any potential for personal injury.**
- 12. Except where specifically stated, all tests are carried out at room (ambient) temperature and relative humidity conditions of 25°C, 65% RH. The test value is only for fan performance itself.**
- 13. Be certain to connect an “ 4.7 μ F or greater” capacitor to the fan externally when the application calls for using multiple fans in parallel, to avoid any unstable power.**

5. Material Certification

5.1. PBT

5.2. AL6063-T5

5.3. PC

5.4. PET 、 INK 、 COATING

5.5. DOW TC-1996

Test Report

No. : CE/2012/A3314

Date : 2012/10/22

Page: 1 of 5

SHINKONG SYNTHETIC FIBERS CORPORATION
(SHINKONG INDUSTRY (HANGZHOU) CO., LTD.)
8F., NO. 123, SEC. 2, NANKING E. RD., TAIPEI, TAIWAN
(NO.1, AVENUE 6, ECONOMY & TECHNOLOGY DEVELOPMENT ZONE, HANGZHOU, CHINA)



The following sample(s) was/were submitted and identified by/on behalf of the client as:

Sample Description : THERMOPLASTIC POLYESTER RESIN
Style/Item No. : SHINITE[®] PBT D202G30BK
Sample Receiving Date : 2012/10/16
Testing Period : 2012/10/16 TO 2012/10/22

=====
Test Requested : As specified by client, with reference to RoHS Directive 2011/65/EU Annex II to determine Cadmium, Lead, Mercury, Cr(VI), PBBs, PBDEs contents in the submitted sample.
Test Method : With reference to IEC 62321: 2008.
Test Result(s) : Please refer to next page(s).
Conclusion : Based on the performed tests on submitted samples, the test results of Cadmium, Lead, Mercury, Cr(VI), PBBs, PBDEs comply with the limits as set by RoHS Directive 2011/65/EU Annex II; recasting 2002/95/EC.



Chenyu Kung / Operation Manager
Signed for and on behalf of
SGS TAIWAN LTD.
Chemical Laboratory – Taipei

Unless otherwise stated the results shown in this test report refer only to the sample(s) tested. This test report cannot be reproduced, except in full, without prior written permission of the Company. 除非另有說明，此報告結果僅對測試之樣品負責。本報告未經本公司書面許可，不可部分複製。
This document is issued by the Company subject to its General Conditions of Service printed overleaf, available on request or accessible at www.sgs.com/terms_and_conditions.htm and, for electronic format documents, subject to Terms and Conditions for Electronic Documents at www.sgs.com/en/Terms-and-Conditions/Terms-e-Documents. Attention is drawn to the limitation of liability, indemnification and jurisdiction issues defined therein. Any holder of this document is advised that information contained hereon reflects the Company's findings at the time of its intervention only and within the limits of Client's instructions, if any. The Company's sole responsibility is to its Client and this document does not exonerate parties to a transaction from exercising all their rights and obligations under the transaction documents. This document cannot be reproduced except in full, without prior written approval of the Company. Any unauthorized alteration, forgery or falsification of the content or appearance of this document is unlawful and offenders may be prosecuted to the fullest extent of the law.

Test Report

No. : CE/2012/A3314

Date : 2012/10/22

Page: 2 of 5

SHINKONG SYNTHETIC FIBERS CORPORATION
 (SHINKONG INDUSTRY (HANGZHOU) CO., LTD.)
 8F., NO. 123, SEC. 2, NANKING E. RD., TAIPEI, TAIWAN
 (NO.1, AVENUE 6, ECONOMY & TECHNOLOGY DEVELOPMENT ZONE, HANGZHOU, CHINA)



Test Result(s)

PART NAME No.1 : BLACK PLASTIC PELLETS

Test Item(s)	Unit	Method	MDL	Result	Limit
				No.1	
Cadmium (Cd)	mg/kg	With reference to IEC 62321: 2008 and performed by ICP-AES.	2	n.d.	100
Lead (Pb)	mg/kg		2	12	1000
Mercury (Hg)	mg/kg		2	n.d.	1000
Hexavalent Chromium Cr(VI)	mg/kg	With reference to IEC 62321: 2008 and performed by UV-VIS.	2	n.d.	1000
Sum of PBBs	mg/kg	With reference to IEC 62321: 2008 and performed by GC/MS.	-	n.d.	1000
Monobromobiphenyl	mg/kg		5	n.d.	-
Dibromobiphenyl	mg/kg		5	n.d.	-
Tribromobiphenyl	mg/kg		5	n.d.	-
Tetrabromobiphenyl	mg/kg		5	n.d.	-
Pentabromobiphenyl	mg/kg		5	n.d.	-
Hexabromobiphenyl	mg/kg		5	n.d.	-
Heptabromobiphenyl	mg/kg		5	n.d.	-
Octabromobiphenyl	mg/kg		5	n.d.	-
Nonabromobiphenyl	mg/kg		5	n.d.	-
Decabromobiphenyl	mg/kg		5	n.d.	-
Sum of PBDEs	mg/kg		-	n.d.	1000
Monobromodiphenyl ether	mg/kg		5	n.d.	-
Dibromodiphenyl ether	mg/kg		5	n.d.	-
Tribromodiphenyl ether	mg/kg		5	n.d.	-
Tetrabromodiphenyl ether	mg/kg		5	n.d.	-
Pentabromodiphenyl ether	mg/kg		5	n.d.	-
Hexabromodiphenyl ether	mg/kg	5	n.d.	-	
Heptabromodiphenyl ether	mg/kg	5	n.d.	-	
Octabromodiphenyl ether	mg/kg	5	n.d.	-	
Nonabromodiphenyl ether	mg/kg	5	n.d.	-	
Decabromodiphenyl ether	mg/kg	5	n.d.	-	

Note :

1. mg/kg = ppm ; 0.1wt% = 1000ppm
2. n.d. = Not Detected
3. MDL = Method Detection Limit
4. " - " = Not Regulated

Unless otherwise stated the results shown in this test report refer only to the sample(s) tested. This test report cannot be reproduced, except in full, without prior written permission of the Company. 除非另有說明，此報告結果僅對測試之樣品負責。本報告未經本公司書面許可，不可部分複製。
 This document is issued by the Company subject to its General Conditions of Service printed overleaf, available on request or accessible at www.sgs.com/terms_and_conditions.htm and, for electronic format documents, subject to Terms and Conditions for Electronic Documents at www.sgs.com/en/Terms-and-Conditions/Terms-e-Document. Attention is drawn to the limitation of liability, indemnification and jurisdiction issues defined therein. Any holder of this document is advised that information contained hereon reflects the Company's findings at the time of its intervention only and within the limits of Client's instructions, if any. The Company's sole responsibility is to its Client and this document does not exonerate parties to a transaction from exercising all their rights and obligations under the transaction documents. This document cannot be reproduced except in full, without prior written approval of the Company. Any unauthorized alteration, forgery or falsification of the content or appearance of this document is unlawful and offenders may be prosecuted to the fullest extent of the law.

Test Report

No. : CE/2012/A3314

Date : 2012/10/22

Page: 3 of 5

SHINKONG SYNTHETIC FIBERS CORPORATION
 (SHINKONG INDUSTRY (HANGZHOU) CO., LTD.)
 8F., NO. 123, SEC. 2, NANKING E. RD., TAIPEI, TAIWAN
 (NO.1, AVENUE 6, ECONOMY & TECHNOLOGY DEVELOPMENT ZONE, HANGZHOU, CHINA)



- 1) These samples were dissolved totally by pre-conditioning method according to below flow chart.
 (Cr⁶⁺ test method excluded)
- 2) Name of the person who made measurement: Climbgreat Yang
- 3) Name of the person in charge of measurement: Troy Chang

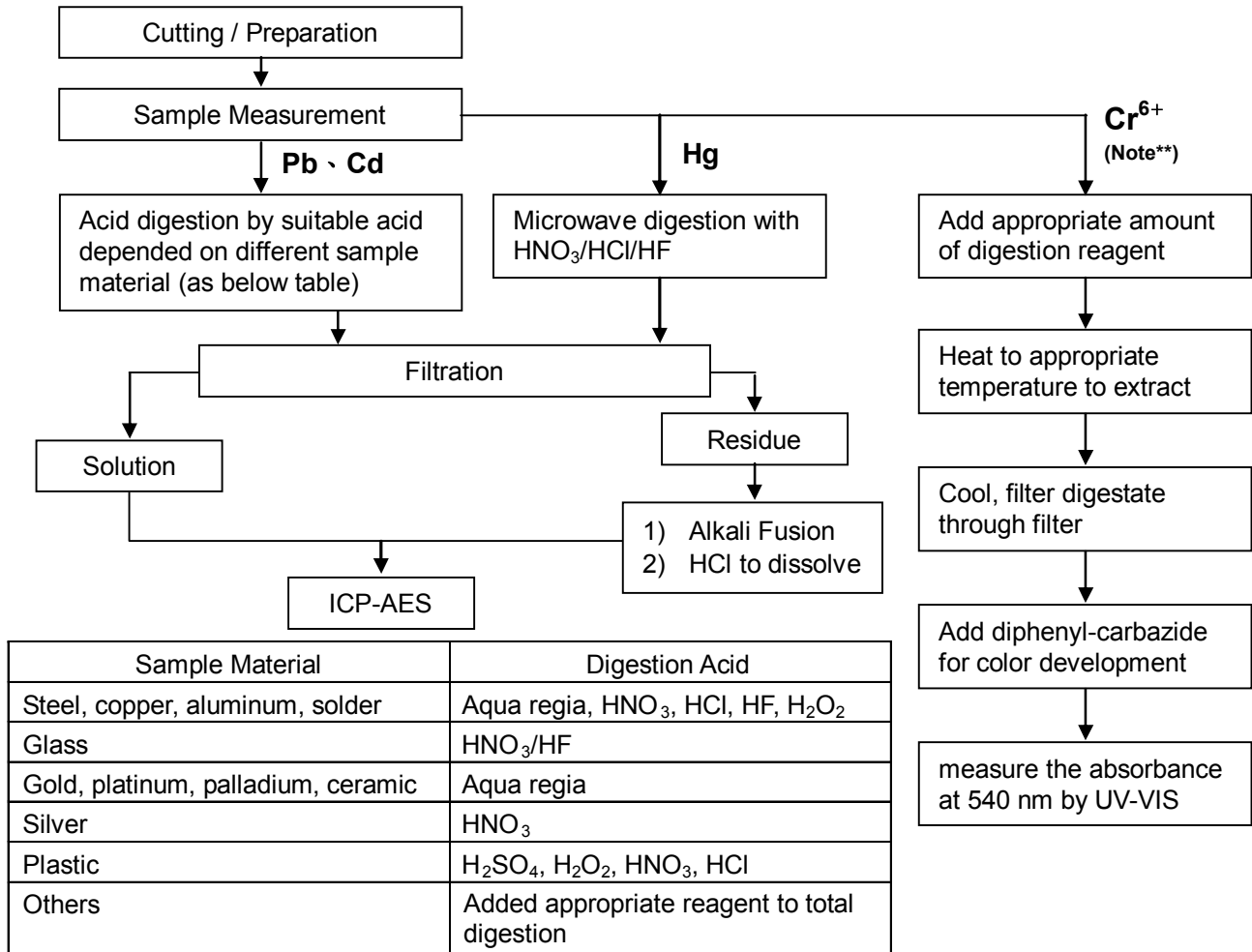

Note :** (1) For non-metallic material, add alkaline digestion reagent and heat to 90~95 °C.
 (2) For metallic material, add pure water and heat to boiling.

Unless otherwise stated the results shown in this test report refer only to the sample(s) tested. This test report cannot be reproduced, except in full, without prior written permission of the Company. 除非另有說明，此報告結果僅對測試之樣品負責。本報告未經本公司書面許可，不可部分複製。
 This document is issued by the Company subject to its General Conditions of Service printed overleaf, available on request or accessible at www.sgs.com/terms_and_conditions.htm and, for electronic format documents, subject to Terms and Conditions for Electronic Documents at www.sgs.com/en/Terms-and-Conditions/Terms-e-Document. Attention is drawn to the limitation of liability, indemnification and jurisdiction issues defined therein. Any holder of this document is advised that information contained hereon reflects the Company's findings at the time of its intervention only and within the limits of Client's instructions, if any. The Company's sole responsibility is to its Client and this document does not exonerate parties to a transaction from exercising all their rights and obligations under the transaction documents. This document cannot be reproduced except in full, without prior written approval of the Company. Any unauthorized alteration, forgery or falsification of the content or appearance of this document is unlawful and offenders may be prosecuted to the fullest extent of the law.

SHINKONG SYNTHETIC FIBERS CORPORATION
 (SHINKONG INDUSTRY (HANGZHOU) CO., LTD.)
 8F., NO. 123, SEC. 2, NANKING E. RD., TAIPEI, TAIWAN
 (NO.1, AVENUE 6, ECONOMY & TECHNOLOGY DEVELOPMENT ZONE, HANGZHOU, CHINA)



PBB/PBDE analytical FLOW CHART

- Name of the person who made measurement: Roman Wong
- Name of the person in charge of measurement: Troy Chang

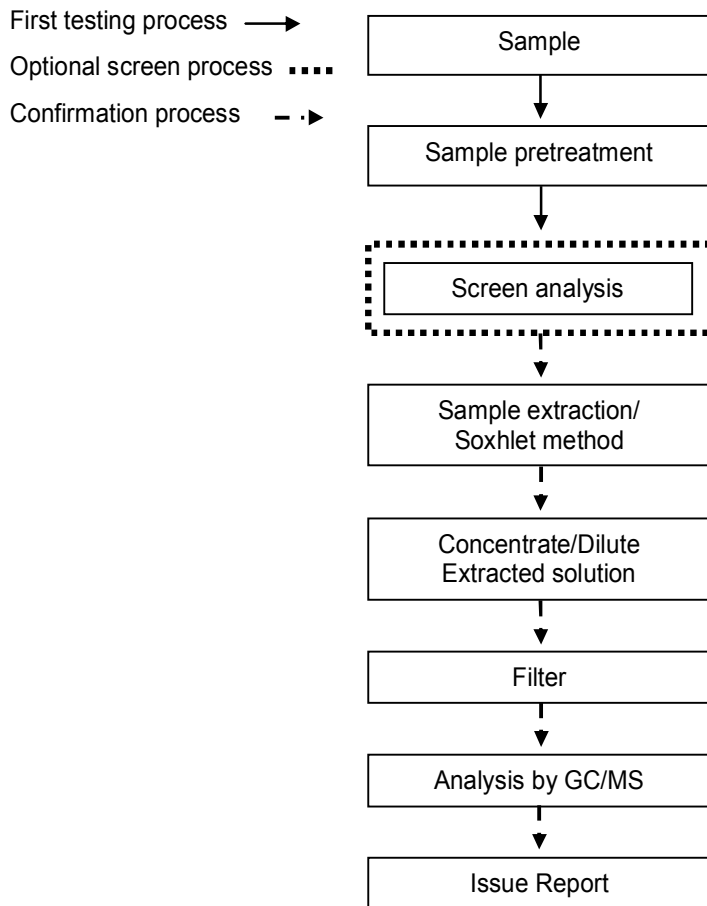

Unless otherwise stated the results shown in this test report refer only to the sample(s) tested. This test report cannot be reproduced, except in full, without prior written permission of the Company. 除非另有說明，此報告結果僅對測試之樣品負責。本報告未經本公司書面許可，不可部分複製。
 This document is issued by the Company subject to its General Conditions of Service printed overleaf, available on request or accessible at www.sgs.com/terms_and_conditions.htm and, for electronic format documents, subject to Terms and Conditions for Electronic Documents at www.sgs.com/en/Terms-and-Conditions/Terms-e-Document. Attention is drawn to the limitation of liability, indemnification and jurisdiction issues defined therein. Any holder of this document is advised that information contained hereon reflects the Company's findings at the time of its intervention only and within the limits of Client's instructions, if any. The Company's sole responsibility is to its Client and this document does not exonerate parties to a transaction from exercising all their rights and obligations under the transaction documents. This document cannot be reproduced except in full, without prior written approval of the Company. Any unauthorized alteration, forgery or falsification of the content or appearance of this document is unlawful and offenders may be prosecuted to the fullest extent of the law.

Test Report

No. : CE/2012/A3314

Date : 2012/10/22

Page: 5 of 5

SHINKONG SYNTHETIC FIBERS CORPORATION
(SHINKONG INDUSTRY (HANGZHOU) CO., LTD.)
8F., NO. 123, SEC. 2, NANKING E. RD., TAIPEI, TAIWAN
(NO.1, AVENUE 6, ECONOMY & TECHNOLOGY DEVELOPMENT ZONE, HANGZHOU, CHINA)



* The tested sample / part is marked by an arrow if it's shown on the photo. *

CE/2012/A3314



** End of Report **

Unless otherwise stated the results shown in this test report refer only to the sample(s) tested. This test report cannot be reproduced, except in full, without prior written permission of the Company. 除非另有說明，此報告結果僅對測試之樣品負責。本報告未經本公司書面許可，不可部分複製。
This document is issued by the Company subject to its General Conditions of Service printed overleaf, available on request or accessible at www.sgs.com/terms_and_conditions.htm and, for electronic format documents, subject to Terms and Conditions for Electronic Documents at www.sgs.com/en/Terms-and-Conditions/Terms-e-Document. Attention is drawn to the limitation of liability, indemnification and jurisdiction issues defined therein. Any holder of this document is advised that information contained hereon reflects the Company's findings at the time of its intervention only and within the limits of Client's instructions, if any. The Company's sole responsibility is to its Client and this document does not exonerate parties to a transaction from exercising all their rights and obligations under the transaction documents. This document cannot be reproduced except in full, without prior written approval of the Company. Any unauthorized alteration, forgery or falsification of the content or appearance of this document is unlawful and offenders may be prosecuted to the fullest extent of the law.

HUIZHOU CITY JINGXIN ALUMINUM INDUSTRY TECHNOLOGY CO.,LTD

HUAN SHENG INDUSTRY PARK LONG QIAO BIG WAY LONGXI TOWN,BO LUO COUNTY,HUIZHOU
CITY,GUANGDONG PROVINCE,CHINA

The following sample(s) was/were submitted and identified on behalf of the clients as : ALUMINUM TYPE
MATERIAL

SGS Job No. : CP13-002258 - SZ
Client Ref. Info. : Material: AL6063-T5
Sample color: Silver white
Lot No. : A15B130114DC
Supplier : JINGXIN
Buyer : Buyer
Date of Sample Received : 16 Jan 2013
Testing Period : 16 Jan 2013 - 23 Jan 2013
Test Requested : Selected test(s) as requested by client.
Test Method : Please refer to next page(s).
Test Results : Please refer to next page(s).

Signed for and on behalf of
SGS-CSTC Ltd.



Kenny Wang
Approved Signatory

This document is issued by the Company subject to its General Conditions of Service printed overleaf, available on request or accessible at http://www.sgs.com/terms_and_conditions.htm and, for electronic format documents, subject to Terms and Conditions for Electronic Documents at www.sgs.com/terms_e-document.htm. Attention is drawn to the limitation of liability, indemnification and jurisdiction issues defined therein. Any holder of this document is advised that information contained hereon reflects the Company's findings at the time of its preparation only, and within the limits of Client's instructions, if any. The Company's sole responsibility is to its Client and this document does not exonerate parties to a transaction from exercising all their rights and obligations under the transaction documents. This document cannot be reproduced except in full, without prior written approval of the Company. Any unauthorized alteration, forgery or falsification of the content or appearance of this document is unlawful and offenders may be prosecuted to the fullest extent of the law. Unless otherwise stated, the results shown in this test report refer only to the sample(s) tested.

Test Results :

Test Part Description :

Specimen No.	SGS Sample ID	Description
1	CAN13-008615.002	Silvery metal

Remarks :

- (1) 1 mg/kg = 1 ppm = 0.0001%
- (2) MDL = Method Detection Limit
- (3) ND = Not Detected (< MDL)
- (4) "-" = Not Regulated

Elementary Analysis

Test Method : With reference to IEC 62321:2008

- (1) Determination of Cadmium by ICP-OES.
- (2) Determination of Lead by ICP-OES.
- (3) Determination of Mercury by ICP-OES.
- (4) Determination of Hexavalent Chromium by Spot test / Colorimetric Method using UV-Vis.

<u>Test Item(s)</u>	<u>Unit</u>	<u>MDL</u>	<u>002</u>
Cadmium (Cd)	mg/kg	2	ND
Lead (Pb)	mg/kg	2	15
Mercury (Hg)	mg/kg	2	ND
Hexavalent Chromium (CrVI)	-	◇	Negative

Notes :

- (1)◇Spot-test:
 Negative = Absence of CrVI coating, Positive = Presence of CrVI coating;
 (The tested sample should be further verified by boiling-water-extraction method if the spot test result is Negative or cannot be confirmed.)
 ◇Boiling-water-extraction:
 Negative = Absence of CrVI coating
 Positive = Presence of CrVI coating; the detected concentration in boiling-water-extraction solution is equal or greater than 0.02 mg/kg with 50 cm² sample surface area.
 Information on storage conditions and production date of the tested sample is unavailable and thus results of Cr(VI) represent status of the sample at the time of testing.

Elementary Analysis

This document is issued by the Company subject to its General Conditions of Service printed overleaf, available on request or accessible at http://www.sgs.com/terms_and_conditions.htm and, for electronic format documents, subject to Terms and Conditions for Electronic Documents at www.sgs.com/terms_e-document.htm. Attention is drawn to the limitation of liability, jurisdiction and jurisdiction issues defined therein. Any holder of this document is advised that information contained hereon reflects the Company's findings at the time of its preparation only and within the limits of Client's instructions, if any. The Company's sole responsibility is to its Client and this document does not exonerate parties to a transaction from exercising all their rights and obligations under the transaction documents. This document cannot be reproduced except in full, without prior written approval of the Company. Any unauthorized alteration, forgery or falsification of the content or appearance of this document is unlawful and offenders may be prosecuted to the fullest extent of the law. Unless otherwise stated, the results shown in this test report refer only to the sample(s) tested.

Test Report

No. CANEC1300861502

Date: 23 Jan 2013

Page 3 of 7

Test Method : With reference to US EPA Method 3050B:1996, analysis was performed by ICP-OES.

<u>Test Item(s)</u>	<u>Unit</u>	<u>MDL</u>	<u>002</u>
Arsenic (As)	mg/kg	10	ND

PFOS (Perfluorooctane Sulfonates)

Test Method : With reference to US EPA 3550C: 2007, analysis was performed by HPLC-MS.

<u>Test Item(s)</u>	<u>Unit</u>	<u>MDL</u>	<u>002</u>
Perfluorooctane Sulfonates (PFOS) and related Acid, Metal Salt and Amide	mg/kg	10	ND

Notes :

For reference: commission regulation (EU) No 757/2010 amending regulation (EC) No 850/2004:

- (1) For the purposes of this entry, Article 4(1) (b) shall apply to concentrations of PFOS equal to or below 10 mg/kg (0,001 % by weight) when it occurs in substances or in preparations.
- (2) For the purposes of this entry, Article 4(1) (b) shall apply to concentrations of PFOS in semi-finished products or articles, or parts thereof, if the concentration of PFOS is lower than 0,1 % by weight calculated with reference to the mass of structurally or micro-structurally distinct parts that contain PFOS or, for textiles or other coated materials, if the amount of PFOS is lower than 1µg /m2 of the coated material.

This document is issued by the Company subject to its General Conditions of Service printed overleaf, available on request or accessible at http://www.sgs.com/terms_and_conditions.htm and, for electronic format documents, subject to Terms and Conditions for Electronic Documents at www.sgs.com/terms_e-document.htm. Attention is drawn to the limitation of liability, indemnification and jurisdiction issues defined therein. Any holder of this document is advised that information contained hereon reflects the Company's findings at the time of its preparation only and within the limits of Client's instructions, if any. The Company's sole responsibility is to its Client and this document does not exonerate parties to a transaction from exercising all their rights and obligations under the transaction documents. This document cannot be reproduced except in full, without prior written approval of the Company. Any unauthorized alteration, forgery or falsification of the content or appearance of this document is unlawful and offenders may be prosecuted to the fullest extent of the law. Unless otherwise stated, the results shown in this test report refer only to the sample(s) tested.

ATTACHMENTS

RoHS Testing Flow Chart

- 1) Name of the person who made testing: Michael Tso
- 2) Name of the person in charge of testing: Adams Yu
- 3) These samples were dissolved totally by pre-conditioning method according to below flow chart (Cr6+ test method excluded).

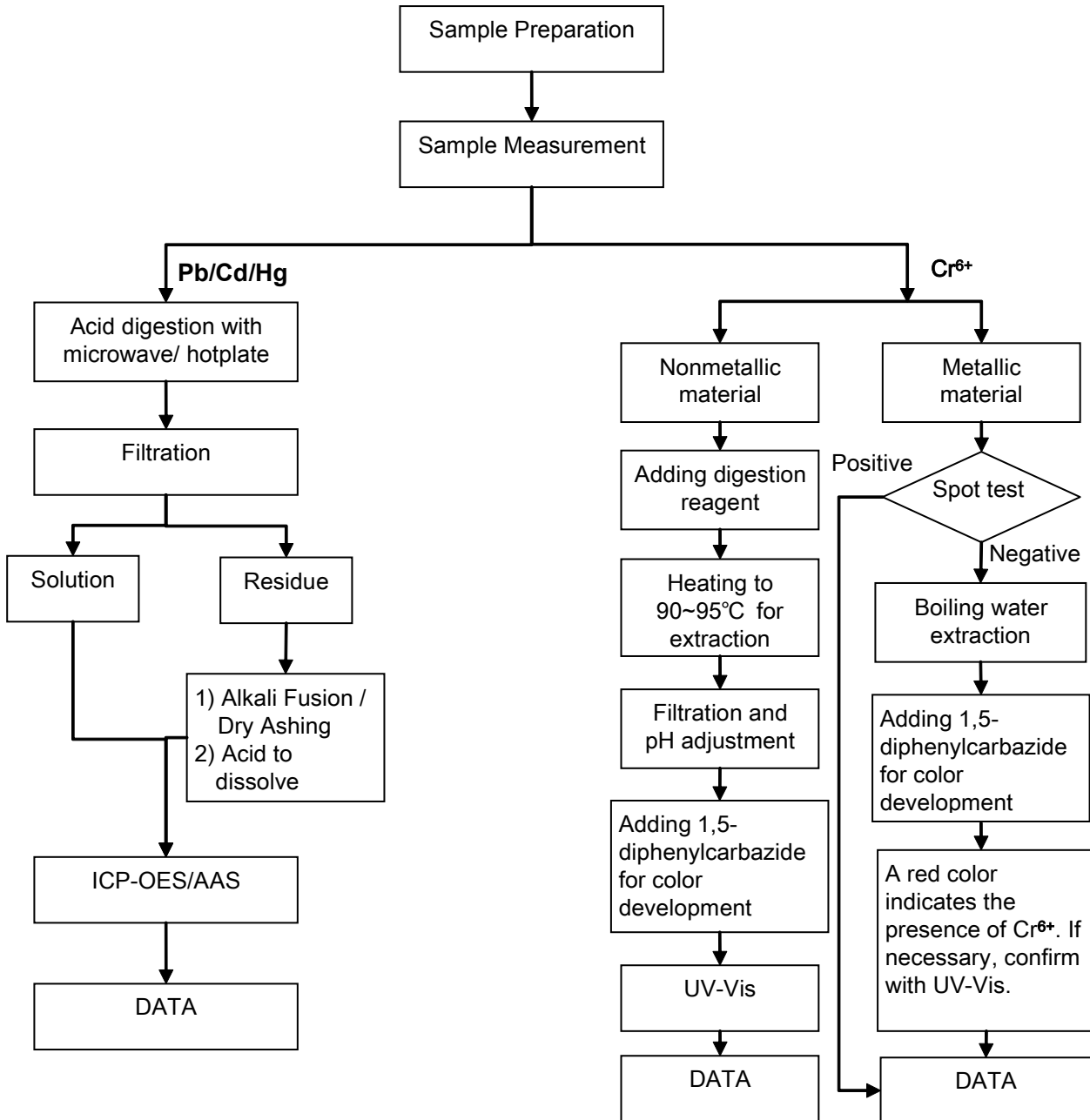

This document is issued by the Company subject to its General Conditions of Service printed overleaf, available on request or accessible at http://www.sgs.com/terms_and_conditions.htm and, for electronic format documents, subject to Terms and Conditions for Electronic Documents at www.sgs.com/terms_e-document.htm. Attention is drawn to the limitation of liability, indemnification and jurisdiction issues defined therein. Any holder of this document is advised that information contained hereon reflects the Company's findings at the time of its preparation only and within the limits of Client's instructions, if any. The Company's sole responsibility is to its Client and this document does not exonerate parties to a transaction from exercising all their rights and obligations under the transaction documents. This document cannot be reproduced except in full, without prior written approval of the Company. Any unauthorized alteration, forgery or falsification of the content or appearance of this document is unlawful and offenders may be prosecuted to the fullest extent of the law. Unless otherwise stated, the results shown in this test report refer only to the sample(s) tested.

ATTACHMENTS

PFOA / PFOS Testing Flow Chart

- 1) Name of the person who made testing: Tina Zhao
- 2) Name of the person in charge of testing: Yolanda Wei

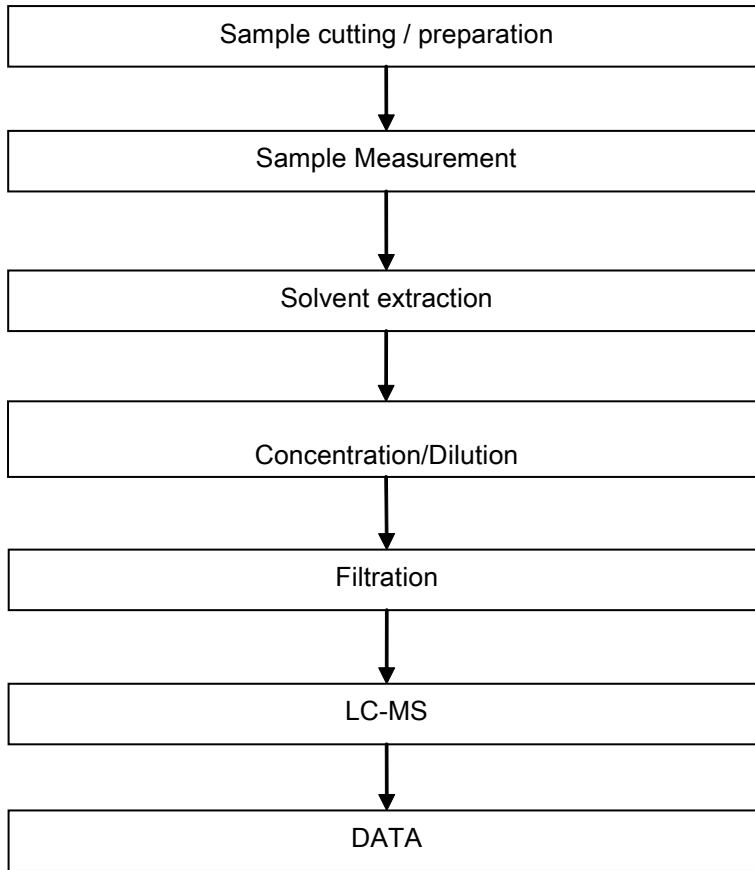

This document is issued by the Company subject to its General Conditions of Service printed overleaf, available on request or accessible at http://www.sgs.com/terms_and_conditions.htm and, for electronic format documents, subject to Terms and Conditions for Electronic Documents at www.sgs.com/terms_e-document.htm. Attention is drawn to the limitation of liability, indemnification and jurisdiction issues defined therein. Any holder of this document is advised that information contained hereon reflects the Company's findings at the time of its preparation only and within the limits of Client's instructions, if any. The Company's sole responsibility is to its Client and this document does not exonerate parties to a transaction from exercising all their rights and obligations under the transaction documents. This document cannot be reproduced except in full, without prior written approval of the Company. Any unauthorized alteration, forgery or falsification of the content or appearance of this document is unlawful and offenders may be prosecuted to the fullest extent of the law. Unless otherwise stated, the results shown in this test report refer only to the sample(s) tested.

ATTACHMENTS

Elementary Testing Flow Chart

- 1) Name of the person who made testing: Bella Wang
- 2) Name of the person in charge of testing: Adams Yu

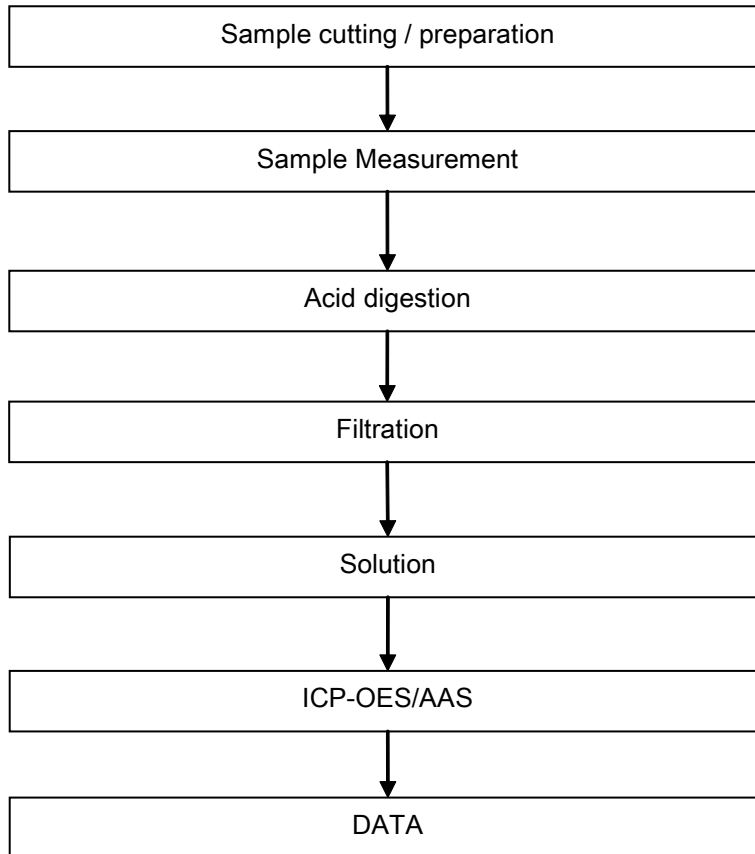

This document is issued by the Company subject to its General Conditions of Service printed overleaf, available on request or accessible at http://www.sgs.com/terms_and_conditions.htm and, for electronic format documents, subject to Terms and Conditions for Electronic Documents at www.sgs.com/terms_e-document.htm. Attention is drawn to the limitation of liability, indemnification and jurisdiction issues defined therein. Any holder of this document is advised that information contained hereon reflects the Company's findings at the time of its preparation only, and within the limits of Client's instructions, if any. The Company's sole responsibility is to its Client and this document does not exonerate parties to a transaction from exercising all their rights and obligations under the transaction documents. This document cannot be reproduced except in full, without prior written approval of the Company. Any unauthorized alteration, forgery or falsification of the content or appearance of this document is unlawful and offenders may be prosecuted to the fullest extent of the law. Unless otherwise stated, the results shown in this test report refer only to the sample(s) tested.

Sample photo:

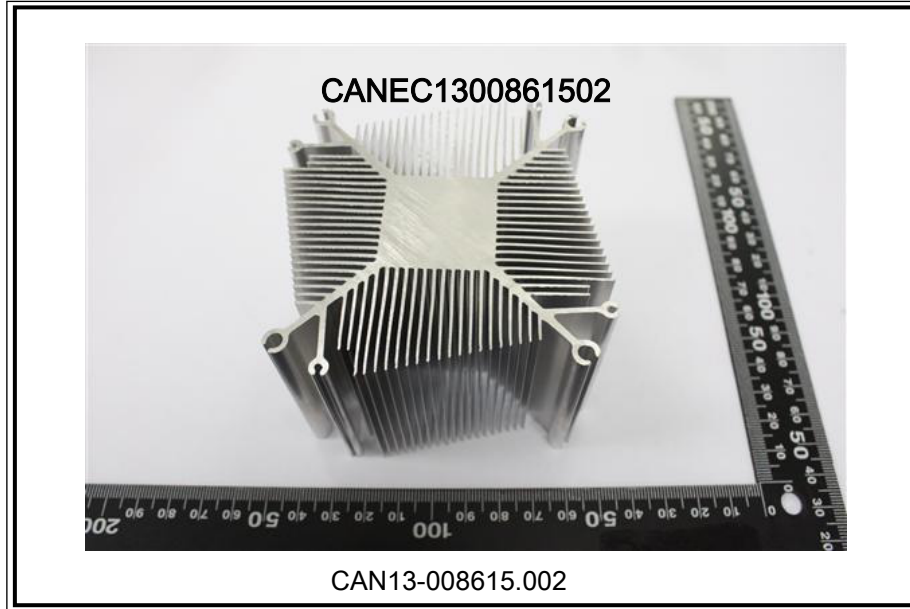

SGS authenticate the photo on original report only

*** End of Report ***

This document is issued by the Company subject to its General Conditions of Service printed overleaf, available on request or accessible at http://www.sgs.com/terms_and_conditions.htm and, for electronic format documents, subject to Terms and Conditions for Electronic Documents at www.sgs.com/terms_e-document.htm. Attention is drawn to the limitation of liability, indemnification and jurisdiction issues defined therein. Any holder of this document is advised that information contained hereon reflects the Company's findings at the time of its preparation only and within the limits of Client's instructions, if any. The Company's sole responsibility is to its Client and this document does not exonerate parties to a transaction from exercising all their rights and obligations under the transaction documents. This document cannot be reproduced except in full, without prior written approval of the Company. Any unauthorized alteration, forgery or falsification of the content or appearance of this document is unlawful and offenders may be prosecuted to the fullest extent of the law. Unless otherwise stated, the results shown in this test report refer only to the sample(s) tested.

測試報告 Test Report

號碼(No.) : KA/2012/70394 日期(Date) : 2012/07/11 頁數(Page) : 1 of 9

安天德百電股份有限公司
ITW ELECTRONIC BUSINESS ASIA CO., LTD.
高雄市前鎮加工出口區東六街3-2號
A4, 3-2, K.E.P.Z. KAOHSIUNG, TAIWAN

以下測試樣品係由客戶送樣，且由客戶聲稱並經客戶確認如下 (The following samples was/were submitted and identified by/on behalf of the client as) :

樣品名稱(Sample Description) : SABIC LEXAN PC
樣品型號(Style/Item No.) : 3412ECR-739
收件日期(Sample Receiving Date) : 2012/07/05
測試期間(Testing Period) : 2012/07/05 TO 2012/07/11
送樣廠商(Sample Submitted By) : 安天德百電股份有限公司 (ITW ELECTRONIC BUSINESS ASIA CO., LTD.)

=====
測試結果(Test Results) : 請見下一頁 (Please refer to next pages).

Ray Chang / Asst. Manager
Signed for and on behalf of
SGS Taiwan Limited



測試報告

Test Report

號碼(No.) : KA/2012/70394 日期(Date) : 2012/07/11 頁數(Page) : 2 of 9

安天德百電股份有限公司
ITW ELECTRONIC BUSINESS ASIA CO., LTD.
高雄市前鎮加工出口區東六街3-2號
A4, 3-2, K.E.P.Z. KAOHSIUNG, TAIWAN

測試結果(Test Results)

測試部位(PART NAME) NO.1 : 黑色 SABIC LEXAN PC (BLACK SABIC LEXAN PC)

測試項目 (Test Items)	單位 (Unit)	測試方法 (Method)	方法偵測 極限值 (MDL)	結果 (Result)
				NO.1
鎘 / Cadmium (Cd)	mg/kg	參考IEC 62321: 2008方法, 用感應耦合電漿原子發射光譜儀檢測. / With reference to IEC 62321: 2008 and performed by ICP-AES.	2	n.d.
鉛 / Lead (Pb)	mg/kg	參考IEC 62321: 2008方法, 用感應耦合電漿原子發射光譜儀檢測. / With reference to IEC 62321: 2008 and performed by ICP-AES.	2	6.34
汞 / Mercury (Hg)	mg/kg	參考IEC 62321: 2008方法, 用感應耦合電漿原子發射光譜儀檢測. / With reference to IEC 62321: 2008 and performed by ICP-AES.	2	n.d.
六價鉻 / Hexavalent Chromium Cr(VI) by alkaline extraction	mg/kg	參考IEC 62321: 2008方法, 用UV-VIS檢測. / With reference to IEC 62321: 2008 and performed by UV-VIS.	2	n.d.
全氟辛烷磺酸 / Perfluorooctane sulfonates (PFOS - Acid, Metal Salt, Amide)	mg/kg	參考US EPA 3550C: 2007方法, 以液相層析/質譜儀檢測. / With reference to US EPA 3550C: 2007. Analysis was performed by LC/MS.	10	n.d.
全氟辛酸(銨) / PFOA (CAS No.: 335-67-1)	mg/kg	參考US EPA 3550C: 2007方法, 以液相層析/質譜儀檢測. / With reference to US EPA 3550C: 2007. Analysis was performed by LC/MS.	10	n.d.

Unless otherwise stated the results shown in this test report refer only to the sample(s) tested. This test report cannot be reproduced, except in full, without prior written permission of the Company. 除非另有說明, 此報告結果僅對測試之樣品負責。本報告未經本公司書面許可, 不可部分複製。
This document is issued by the Company subject to its General Conditions of Service printed overleaf, available on request or accessible at www.sgs.com/terms_and_conditions.htm and, for electronic format documents, subject to Terms and Conditions for Electronic Documents at www.sgs.com/terms_e-document.htm. Attention is drawn to the limitation of liability, indemnification and jurisdiction issues defined therein. Any holder of this document is advised that information contained hereon reflects the Company's findings at the time of its intervention only and within the limits of Client's instructions, if any. The Company's sole responsibility is to its Client and this document does not exonerate parties to a transaction from exercising all their rights and obligations under the transaction documents. This document cannot be reproduced except in full, without prior written approval of the Company. Any unauthorized alteration, forgery or falsification of the content or appearance of this document is unlawful and offenders may be prosecuted to the fullest extent of the law.

測試報告

Test Report

號碼(No.) : KA/2012/70394 日期(Date) : 2012/07/11 頁數(Page) : 3 of 9

安天德百電股份有限公司
ITW ELECTRONIC BUSINESS ASIA CO., LTD.
高雄市前鎮加工出口區東六街3-2號
A4, 3-2, K.E.P.Z. KAOHSIUNG, TAIWAN

測試項目 (Test Items)	單位 (Unit)	測試方法 (Method)	方法偵測 極限值 (MDL)	結果 (Result)
				NO.1
多溴聯苯總和 / Sum of PBBs	mg/kg	參考IEC 62321: 2008方法, 以氣相層析儀/質譜儀檢測. / With reference to IEC 62321: 2008 and performed by GC/MS.	-	n.d.
一溴聯苯 / Monobromobiphenyl			5	n.d.
二溴聯苯 / Dibromobiphenyl			5	n.d.
三溴聯苯 / Tribromobiphenyl			5	n.d.
四溴聯苯 / Tetrabromobiphenyl			5	n.d.
五溴聯苯 / Pentabromobiphenyl			5	n.d.
六溴聯苯 / Hexabromobiphenyl			5	n.d.
七溴聯苯 / Heptabromobiphenyl			5	n.d.
八溴聯苯 / Octabromobiphenyl			5	n.d.
九溴聯苯 / Nonabromobiphenyl			5	n.d.
十溴聯苯 / Decabromobiphenyl			5	n.d.
多溴聯苯醚總和 / Sum of PBDEs	mg/kg	參考IEC 62321: 2008方法, 以氣相層析儀/質譜儀檢測. / With reference to IEC 62321: 2008 and performed by GC/MS.	-	n.d.
一溴聯苯醚 / Monobromodiphenyl ether			5	n.d.
二溴聯苯醚 / Dibromodiphenyl ether			5	n.d.
三溴聯苯醚 / Tribromodiphenyl ether			5	n.d.
四溴聯苯醚 / Tetrabromodiphenyl ether			5	n.d.
五溴聯苯醚 / Pentabromodiphenyl ether			5	n.d.
六溴聯苯醚 / Hexabromodiphenyl ether			5	n.d.
七溴聯苯醚 / Heptabromodiphenyl ether			5	n.d.
八溴聯苯醚 / Octabromodiphenyl ether			5	n.d.
九溴聯苯醚 / Nonabromodiphenyl ether			5	n.d.
十溴聯苯醚 / Decabromodiphenyl ether			5	n.d.
鹵素(溴) / Halogen-Bromine (Br) (CAS No.: 010097-32-2)	mg/kg	參考BS EN 14582:2007, 以離子層析儀分析. / With reference to BS EN 14582:2007. Analysis was performed by IC.	50	n.d.
鹵素(氯) / Halogen-Chlorine (Cl) (CAS No.: 022537-15-1)	mg/kg	參考BS EN 14582:2007, 以離子層析儀分析. / With reference to BS EN 14582:2007. Analysis was performed by IC.	50	n.d.

Unless otherwise stated the results shown in this test report refer only to the sample(s) tested. This test report cannot be reproduced, except in full, without prior written permission of the Company. 除非另有說明, 此報告結果僅對測試之樣品負責。本報告未經本公司書面許可, 不可部分複製。
This document is issued by the Company subject to its General Conditions of Service printed overleaf, available on request or accessible at www.sgs.com/terms_and_conditions.htm and, for electronic format documents, subject to Terms and Conditions for Electronic Documents at www.sgs.com/terms_e-document.htm. Attention is drawn to the limitation of liability, indemnification and jurisdiction issues defined therein. Any holder of this document is advised that information contained hereon reflects the Company's findings at the time of its intervention only and within the limits of Client's instructions, if any. The Company's sole responsibility is to its Client and this document does not exonerate parties to a transaction from exercising all their rights and obligations under the transaction documents. This document cannot be reproduced except in full, without prior written approval of the Company. Any unauthorized alteration, forgery or falsification of the content or appearance of this document is unlawful and offenders may be prosecuted to the fullest extent of the law.

測試報告 Test Report

號碼(No.) : KA/2012/70394 日期(Date) : 2012/07/11 頁數(Page) : 4 of 9

安天德百電股份有限公司
ITW ELECTRONIC BUSINESS ASIA CO., LTD.
高雄市前鎮加工出口區東六街3-2號
A4, 3-2, K.E.P.Z. KAOHSIUNG, TAIWAN

備註(Note) :

1. mg/kg = ppm ; 0.1wt% = 1000ppm
2. n.d. = Not Detected (未檢出)
3. MDL = Method Detection Limit (方法偵測極限值)
4. "-" = Not Regulated (無規格值)

PFOS參考資訊(Reference Information) : 持久性有機污染物 POPs - (EU) 757/2010

PFOS濃度在物質或製備中不得超過0.001%(10ppm)，在半成品、成品或零部件中不得超過0.1%(1000ppm)，在紡織品或塗層材料中不得超過 $1\mu\text{g}/\text{m}^2$ 。(Outlawing PFOS as substances or preparations in concentrations above 0.001% (10ppm), in semi-finished products or articles or parts at a level above 0.1%(1000ppm), in textiles or other coated materials above $1\mu\text{g}/\text{m}^2$.)

測試報告 Test Report

號碼(No.) : KA/2012/70394 日期(Date) : 2012/07/11 頁數(Page) : 5 of 9

安天德百電股份有限公司
ITW ELECTRONIC BUSINESS ASIA CO., LTD.
高雄市前鎮加工出口區東六街3-2號
A4, 3-2, K.E.P.Z. KAOHSIUNG, TAIWAN

- 1) 根據以下的流程圖之條件，樣品已完全溶解。(六價鉻測試方法除外) / These samples were dissolved totally by pre-conditioning method according to below flow chart. (Cr⁶⁺ test method excluded)
- 2) 測試人員：張俊雄 / Name of the person who made measurement: Alex Chang
- 3) 測試負責人：張伯睿 / Name of the person in charge of measurement: Ray Chang

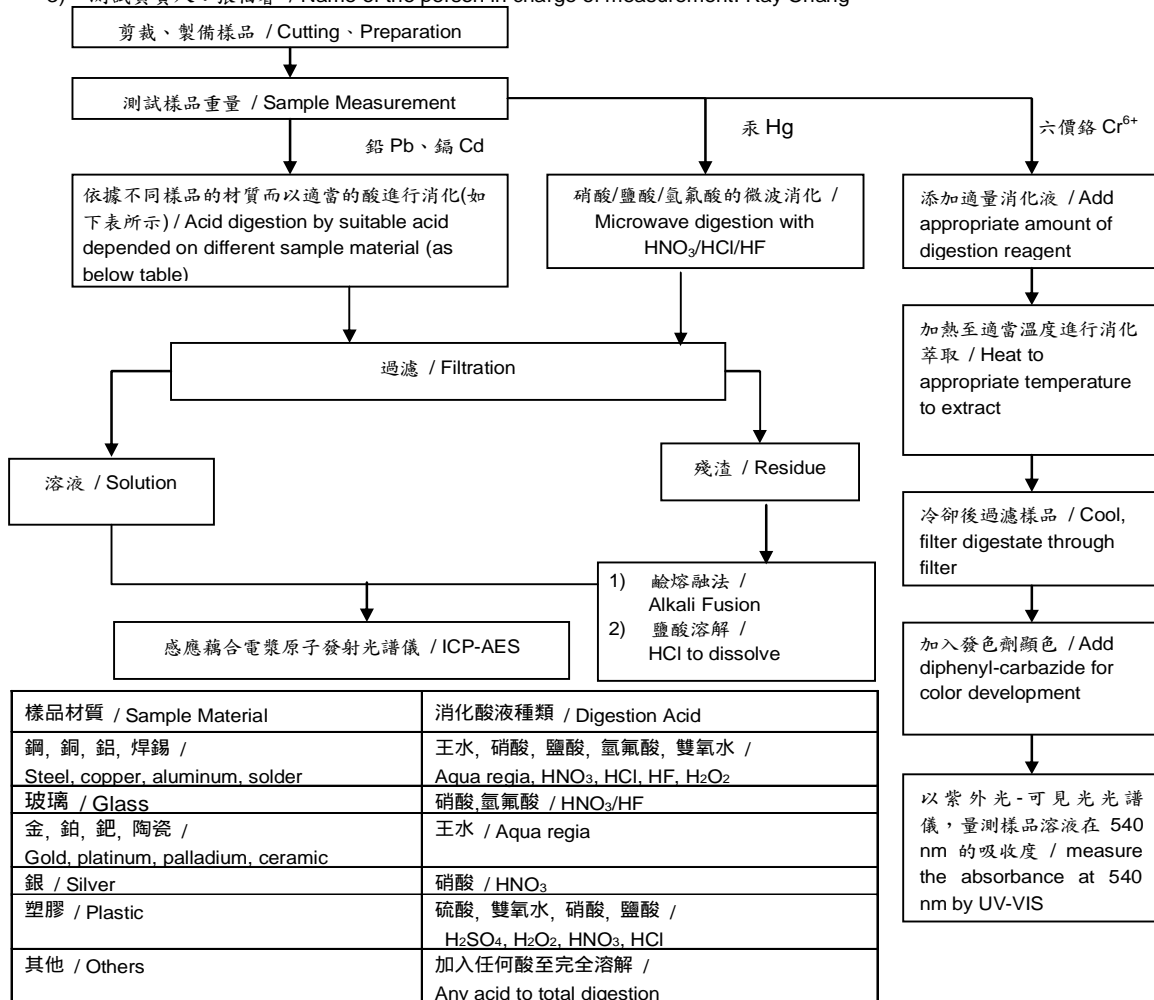

- Note**:** (1) 針對非金屬材料加入鹼性消化液，加熱至 90~95°C 萃取。 / For non-metallic material, add alkaline digestion reagent and heat to 90~95°C.
(2) 針對金屬材料加入純水，加熱至沸騰萃取。 / For metallic material, add pure water and heat to boiling.

測試報告 Test Report

號碼(No.) : KA/2012/70394 日期(Date) : 2012/07/11 頁數(Page) : 6 of 9

安天德百電股份有限公司
ITW ELECTRONIC BUSINESS ASIA CO., LTD.
高雄市前鎮加工出口區東六街3-2號
A4, 3-2, K.E.P.Z. KAOHSIUNG, TAIWAN

多溴聯苯/多溴聯苯醚 分析流程圖 / PBB/PBDE analytical FLOW CHART

- 1) 測試人員：曹嘉琪 / Name of the person who made measurement: Anson Tsao
2) 測試負責人：張伯睿 / Name of the person in charge of measurement: Ray Chang

初次測試程序 / First testing process ———→

選擇性篩檢程序 / Optional screen process→

確認程序 / Confirmation process - - - - -→

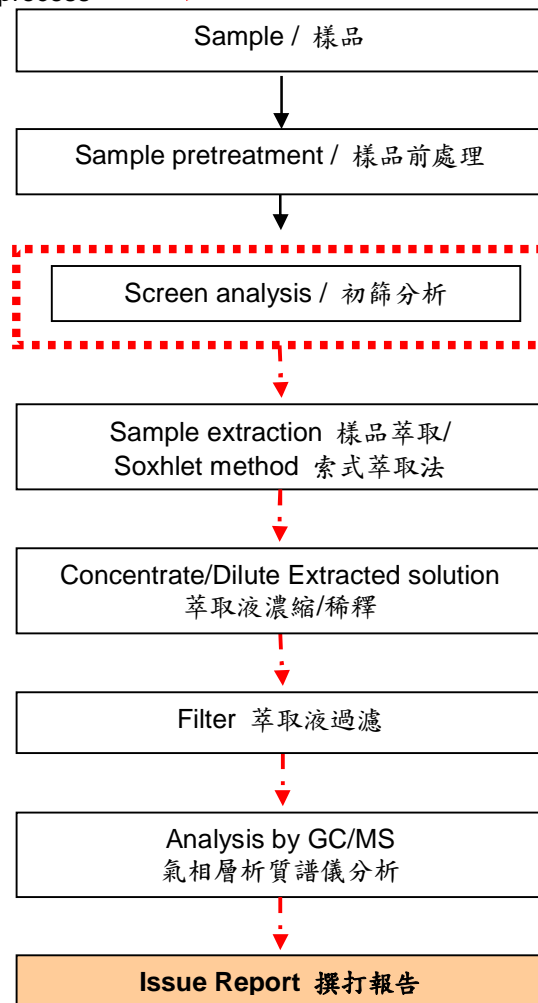

Unless otherwise stated the results shown in this test report refer only to the sample(s) tested. This test report cannot be reproduced, except in full, without prior written permission of the Company. 除非另有說明，此報告結果僅對測試之樣品負責。本報告未經本公司書面許可，不可部分複製。
This document is issued by the Company subject to its General Conditions of Service printed overleaf, available on request or accessible at www.sgs.com/terms_and_conditions.htm and, for electronic format documents, subject to Terms and Conditions for Electronic Documents at www.sgs.com/terms_e-document.htm. Attention is drawn to the limitation of liability, indemnification and jurisdiction issues defined therein. Any holder of this document is advised that information contained hereon reflects the Company's findings at the time of its intervention only and within the limits of Client's instructions, if any. The Company's sole responsibility is to its Client and this document does not exonerate parties to a transaction from exercising all their rights and obligations under the transaction documents. This document cannot be reproduced except in full, without prior written approval of the Company. Any unauthorized alteration, forgery or falsification of the content or appearance of this document is unlawful and offenders may be prosecuted to the fullest extent of the law.

測試報告 Test Report

號碼(No.) : KA/2012/70394 日期(Date) : 2012/07/11 頁數(Page) : 7 of 9

安天德百電股份有限公司
ITW ELECTRONIC BUSINESS ASIA CO., LTD.
高雄市前鎮加工出口區東六街3-2號
A4, 3-2, K.E.P.Z. KAOHSIUNG, TAIWAN

全氟辛酸(銨)/ 全氟辛烷磺酸分析流程圖 /

Analytical flow chart of PFOA/PFOS content

- 1) 測試人員：曹嘉琪 / Name of the person who made measurement: Anson Tsao
2) 測試負責人：張伯睿 / Name of the person in charge of measurement: Ray Chang

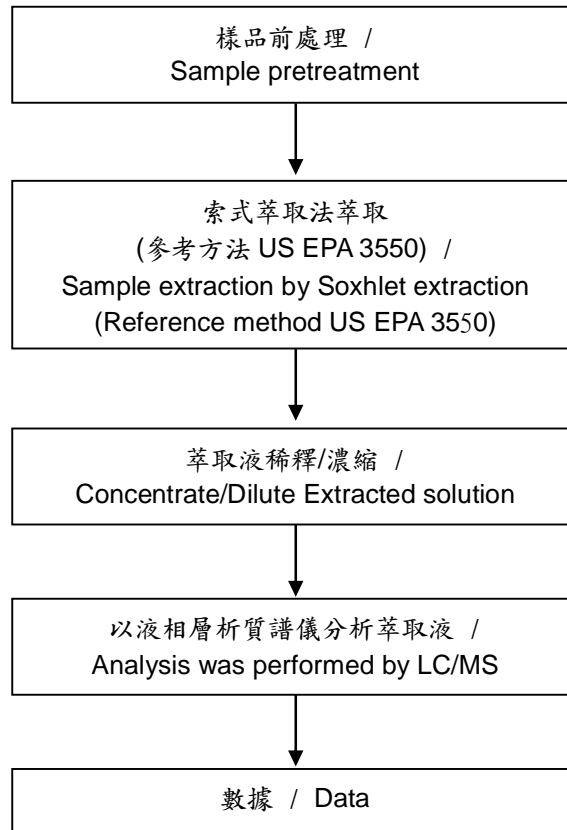

測試報告 Test Report

號碼(No.) : KA/2012/70394 日期(Date) : 2012/07/11 頁數(Page) : 8 of 9

安天德百電股份有限公司
ITW ELECTRONIC BUSINESS ASIA CO., LTD.
高雄市前鎮加工出口區東六街3-2號
A4, 3-2, K.E.P.Z. KAOHSIUNG, TAIWAN

鹵素分析流程圖 / Analytical flow chart of halogen content

- 1) 測試人員：洪秀真 / Name of the person who made measurement: Jean Hung
- 2) 測試負責人：張伯睿 / Name of the person in charge of measurement: Ray Chang

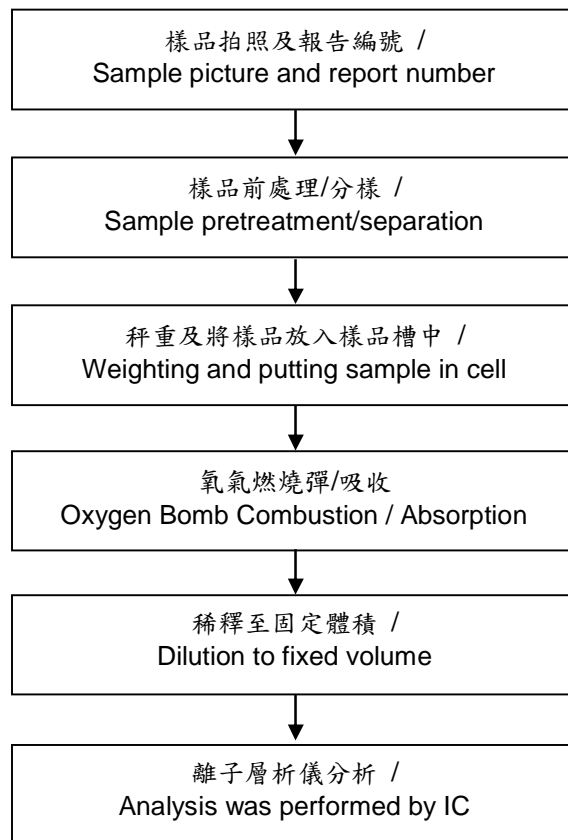

Unless otherwise stated the results shown in this test report refer only to the sample(s) tested. This test report cannot be reproduced, except in full, without prior written permission of the Company. 除非另有說明，此報告結果僅對測試之樣品負責。本報告未經本公司書面許可，不可部分複製。
This document is issued by the Company subject to its General Conditions of Service printed overleaf, available on request or accessible at www.sgs.com/terms_and_conditions.htm and, for electronic format documents, subject to Terms and Conditions for Electronic Documents at www.sgs.com/terms_e-document.htm. Attention is drawn to the limitation of liability, indemnification and jurisdiction issues defined therein. Any holder of this document is advised that information contained hereon reflects the Company's findings at the time of its intervention only and within the limits of Client's instructions, if any. The Company's sole responsibility is to its Client and this document does not exonerate parties to a transaction from exercising all their rights and obligations under the transaction documents. This document cannot be reproduced except in full, without prior written approval of the Company. Any unauthorized alteration, forgery or falsification of the content or appearance of this document is unlawful and offenders may be prosecuted to the fullest extent of the law.

測試報告 Test Report

號碼(No.) : KA/2012/70394 日期(Date) : 2012/07/11 頁數(Page) : 9 of 9

安天德百電股份有限公司
ITW ELECTRONIC BUSINESS ASIA CO., LTD.
高雄市前鎮加工出口區東六街3-2號
A4, 3-2, K.E.P.Z. KAOHSIUNG, TAIWAN

* 照片中如有箭頭標示，則表示為實際檢測之樣品/部位。*
(The tested sample / part is marked by an arrow if it's shown on the photo.)

KA/2012/70394



** 報告結尾(End of Report) **

Test Report

Report No. RLSZE001320600001

Page 1 of 6

Applicant DONGGUAN SUNWAY PRINTING INDUSTRY CO.,LTD
Address YINLING INDUSTRIAL, XIAQIAO GUANLONG ROAD, DONGCHENG ZONE,
DONGGUAN CITY, GUANGDONG PROVINCE, CHINA

The following sample(s) and sample information was/were submitted and identified by/on the behalf of the client

Sample Name 上光PP
Part No. OPAT
COLOR Transparent
Material PP film
Sample Received Date Jun. 14, 2012
Testing Period Jun. 14, 2012 to Jun. 18, 2012

Test Requested As specified by client, to test Lead(Pb), Cadmium(Cd), Mercury(Hg), Hexavalent Chromium(Cr(VI)), Polybrominated Biphenyls(PBBs), Polybrominated Diphenyl Ethers(PBDEs), Three Phthalates (DBP, BBP, DEHP), Hexabromocyclododecane(HBCDD), Chlorine(Cl), Bromine(Br) in the submitted sample and it was tested as a whole.

Test Method Please refer to the following page(s).

Test Result(s) Please refer to the following page(s).

Tested by

Rick Li

Reviewed by

Vargas He

Approved by

Danny Liu

Date

Jun. 18, 2012

Danny Liu

Technical Manager

No. 38792801

Centre Testing International (Shenzhen) Co., Ltd. Hongwei Industrial Zone, Bao'an 70 District, Shenzhen, Guangdong, China

Test Report

Report No. RLSZE001320600001

Page 2 of 6

Test Method

Test Item(s)	Test Method	Measured Equipment(s)	MDL
Lead(Pb)	IEC 62321:2008 Ed.1 Sec.8	ICP-OES	2 mg/kg
Cadmium(Cd)	IEC 62321:2008 Ed.1 Sec.8	ICP-OES	2 mg/kg
Mercury(Hg)	IEC 62321:2008 Ed.1 Sec.7	ICP-OES	2 mg/kg
Hexavalent Chromium(Cr(VI))	IEC 62321:2008 Ed.1 Annex C	UV-Vis	2 mg/kg
Polybrominated Biphenyls(PBBs)	IEC 62321:2008 Ed.1 Annex A	GC-MS	5 mg/kg
Polybrominated Diphenyl Ethers(PBDEs)	IEC 62321:2008 Ed.1 Annex A	GC-MS	5 mg/kg
Chlorine(Cl)	Refer to BS EN 14582:2007	IC	10 mg/kg
Bromine(Br)	Refer to BS EN 14582:2007	IC	10 mg/kg
Three Phthalates (DBP,BBP,DEHP)	Refer to EN 14372:2004	GC-MS	50 mg/kg
Hexabromocyclododecane(HBCDD)	Refer to US EPA 3540C:1996	GC-MS	5 mg/kg

Test Result(s)

Tested Item(s)	Content
Lead(Pb)	N.D.
Cadmium (Cd)	N.D.
Mercury(Hg)	N.D.
Hexavalent Chromium(Cr(VI))	N.D.

Tested Item(s)	Content
Polybrominated Biphenyls(PBBs)	
Monobromobiphenyl	N.D.
Dibromobiphenyl	N.D.
Tribromobiphenyl	N.D.
Tetrabromobiphenyl	N.D.
Pentabromobiphenyl	N.D.
Hexabromobiphenyl	N.D.
Heptabromobiphenyl	N.D.
Octabromobiphenyl	N.D.
Nonabromobiphenyl	N.D.
Decabromobiphenyl	N.D.

Test Report

Report No. RLSZE001320600001

Page 3 of 6

Tested Item(s)	Content
Polybrominated Diphenyl Ethers(PBDEs)	
Monobromodiphenyl ether	N.D.
Dibromodiphenyl ether	N.D.
Tribromodiphenyl ether	N.D.
Tetrabromodiphenyl ether	N.D.
Pentabromodiphenyl ether	N.D.
Hexabromodiphenyl ether	N.D.
Heptabromodiphenyl ether	N.D.
Octabromodiphenyl ether	N.D.
Nonabromodiphenyl ether	N.D.
Decabromodiphenyl ether	N.D.

Tested Item(s)	Content
Halogen(s)	
Chlorine (Cl)	N.D.
Bromine (Br)	N.D.

Tested Item(s)	Content
Hexabromocyclododecane (HBCDD)	N.D.

Tested Item(s)	CAS No.	EC No.	Content
Three Phthalates			
Dibutyl phthalate(DBP)	84-74-2	201-557-4	N.D.
Benzylbutyl phthalate(BBP)	85-68-7	201-622-7	N.D.
Di-2-ethylhexyl phthalate(DEHP)	117-81-7	204-211-0	N.D.

Tested Sample/Part Description Transparent plastic film with adhesive paste

Note: The sample had been dissolved totally tested for Lead, Cadmium, Mercury.
 -MDL = Method Detection Limit
 -N.D. = Not Detected (<MDL)
 -mg/kg = ppm = parts per million

Test Report

Report No. RLSZE001320600001

Page 4 of 6

Test Process

1. Lead(Pb), Cadmium(Cd)

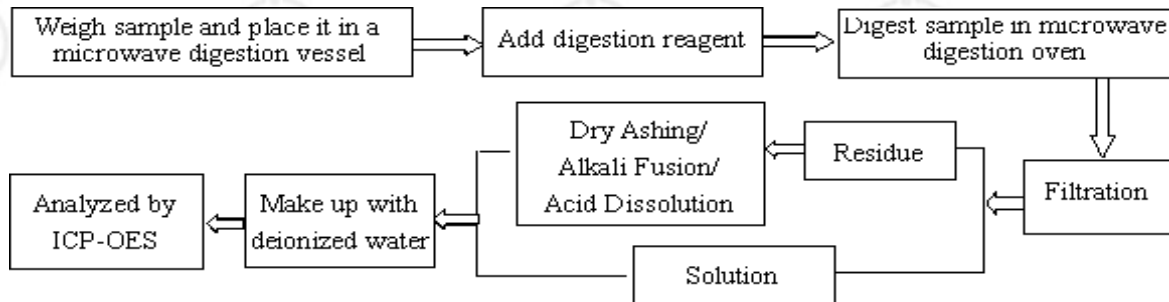

2. Mercury(Hg)

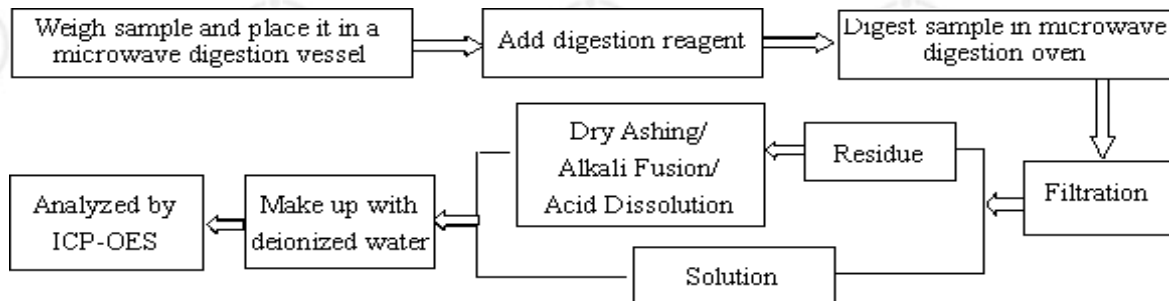

3. Hexavalent Chromium(Cr(VI))

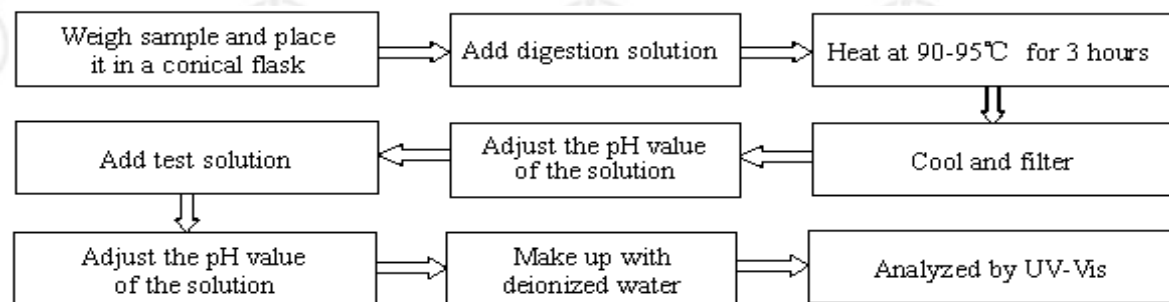

4. Three Phthalates (DBP,BBP,DEHP)

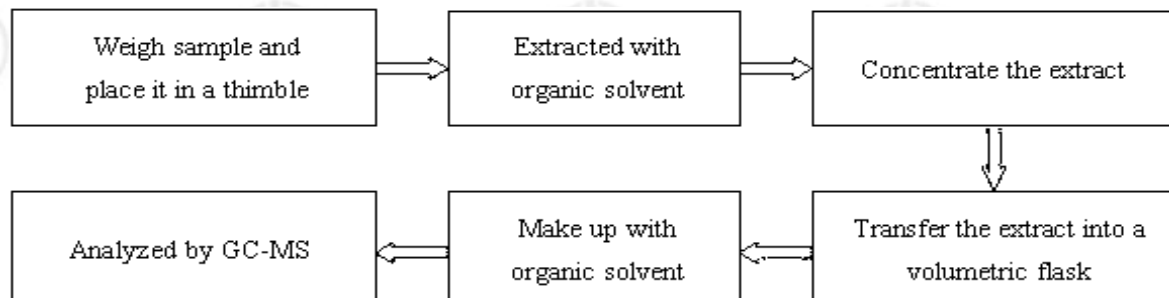

Test Report

Report No. RLSZE001320600001

Page 5 of 6

5. Polybrominated Biphenyls(PBBs), Polybrominated Diphenyl Ethers(PBDEs)

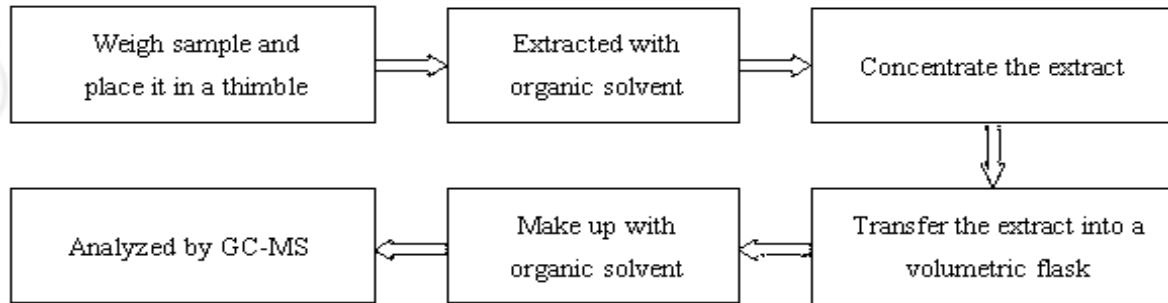

6. Hexabromocyclododecane(HBCDD)

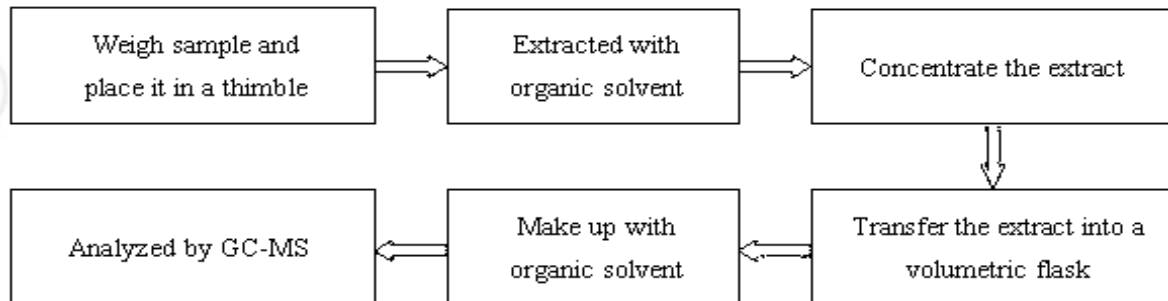

7. Chlorine(Cl), Bromine(Br)

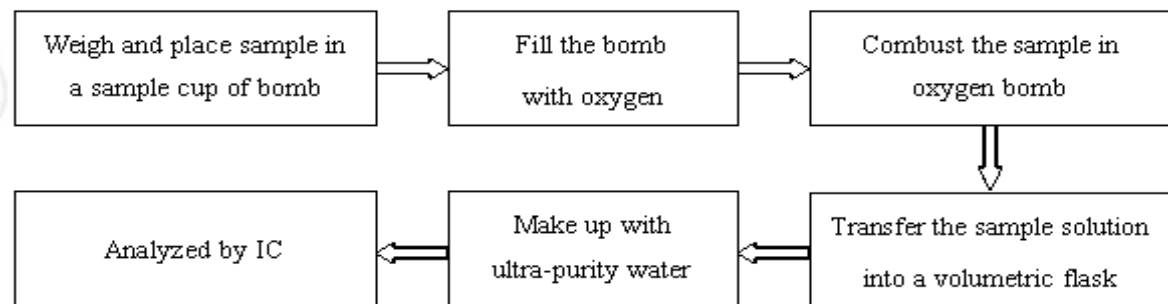

Test Report

Report No. RLSZE001320600001

Page 6 of 6

Photo(s) of the sample(s)



*** End of report ***

The test report is effective only with both signature and specialized stamp. The result(s) shown in this report refer only to the sample(s) tested. Without written approval of CTI, this report can't be reproduced except in full.

Test Report

No. CANEC1215452305

Date: 20 Nov 2012

Page 1 of 10

FOUR PILLARS INDUSTRIAL(SHENZHEN)CO.,LTD.

FOUR PILLARS TECHNOLOGIES & APPLIED MATERIALS(SHENZHEN)CO.,LTD.
FIRST AND SECOND BUILDING,THIRD INDUSTRIAL ZONE,FENGHUANG COUNTRY,FUYONG
TOWN,BAOAN DISTRICT,SHENZHEN ,CHINA

The following sample(s) was/were submitted and identified on behalf of the clients as : Label

SGS Job No. : CP12-054297 - SZ

Lot No. : 20591104

Tested Sample Info. : PO32AZ

Client Ref. Info. : PO32AZ,PO3BZ,PO3MAZ,PO3MZ,PO6BZ,PO6GZ,PO6LZ,
PO6MZ,PO6NZ,PO6TZ,PO6WZ,PO72AZ,PO72BZ,PO72TZ,
PO72Z,PO7MCZ,PO7YZ,PO7NZ,PO92Z,PO94AZ,PO9BHZ,
PO9LZ,PO9MGZ,PO9MHZ,PO9MZ,PO9WZ,POBDZ,POBEZ,
POBGZ,POBHZ,POBKZ

Manufacturer : FOUR PILLARS INDUSTRIAL(SHENZHEN)CO.,LTD.
FOUR PILLARS TECHNOLOGIES & APPLIED
MATERIALS(SHENZHEN)CO.,LTD.

Manufacturer Address : FIRST AND SECOND BUILDING,THIRD INDUSTRIAL ZONE,FENGHUANG
COUNTRY,FUYONG TOWN,BAOAN DISTRICT,SHENZHEN ,CHINA

Date of Sample Received : 14 Nov 2012

Testing Period : 14 Nov 2012 - 20 Nov 2012

Test Requested : Selected test(s) as requested by client.

Test Method : Please refer to next page(s).

Test Results : Please refer to next page(s).

Conclusion : Based on the performed tests on submitted samples, the results of Lead,
Mercury, Cadmium, Hexavalent chromium, Polybrominated biphenyls (PBB),
Polybrominated diphenyl ethers (PBDE) comply with the limits as set by RoHS
Directive 2011/65/EU Annex II; recasting 2002/95/EC.

This document is issued by the Company subject to its General Conditions of Service printed overleaf, available on request or accessible at http://www.sgs.com/terms_and_conditions.htm and, for electronic format documents, subject to Terms and Conditions for Electronic Documents at www.sgs.com/terms_e-document.htm. Attention is drawn to the limitation of liability, indemnification and jurisdiction issues defined therein. Any holder of this document is advised that information contained hereon reflects the Company's findings at the time of its preparation only, and within the limits of Client's instructions, if any. The Company's sole responsibility is to its Client and this document does not exonerate parties to a transaction from exercising all their rights and obligations under the transaction documents. This document cannot be reproduced except in full, without prior written approval of the Company. Any unauthorized alteration, forgery or falsification of the content or appearance of this document is unlawful and offenders may be prosecuted to the fullest extent of the law. Unless otherwise stated, the results shown in this test report refer only to the sample(s) tested.



Test Report

No. CANEC1215452305

Date: 20 Nov 2012

Page 2 of 10

Signed for and on behalf of
SGS-CSTC Ltd.

Almay Gao
Approved Signatory

This document is issued by the Company subject to its General Conditions of Service printed overleaf, available on request or accessible at http://www.sgs.com/terms_and_conditions.htm and, for electronic format documents, subject to Terms and Conditions for Electronic Documents at www.sgs.com/terms_e-document.htm. Attention is drawn to the limitation of liability, indemnification and jurisdiction issues defined therein. Any holder of this document is advised that information contained hereon reflects the Company's findings at the time of its preparation only, and within the limits of Client's instructions, if any. The Company's sole responsibility is to its Client and this document does not exonerate parties to a transaction from exercising all their rights and obligations under the transaction documents. This document cannot be reproduced except in full, without prior written approval of the Company. Any unauthorized alteration, forgery or falsification of the content or appearance of this document is unlawful and offenders may be prosecuted to the fullest extent of the law. Unless otherwise stated, the results shown in this test report refer only to the sample(s) tested.

Test Report

No. CANEC1215452305

Date: 20 Nov 2012

Page 3 of 10

Test Results :

Test Part Description :

Specimen No.	SGS Sample ID	Description
1	CAN12-154523.005	Silvery adhesive sheet

Remarks :

- (1) 1 mg/kg = 1 ppm = 0.0001%
- (2) MDL = Method Detection Limit
- (3) ND = Not Detected (< MDL)
- (4) "-" = Not Regulated

RoHS Directive 2011/65/EU

Test Method : With reference to IEC 62321:2008

- (1) Determination of Cadmium by ICP-OES.
- (2) Determination of Lead by ICP-OES.
- (3) Determination of Mercury by ICP-OES.
- (4) Determination of Hexavalent Chromium by Colorimetric Method using UV-Vis.
- (5) Determination of PBBs / PBDEs content by GC-MS.

Test Item(s)	Limit	Unit	MDL	005
Cadmium (Cd)	100	mg/kg	2	ND
Lead (Pb)	1,000	mg/kg	2	ND
Mercury (Hg)	1,000	mg/kg	2	ND
Hexavalent Chromium (CrVI)	1,000	mg/kg	2	ND
Sum of PBBs	1,000	mg/kg	-	ND
Monobromobiphenyl	-	mg/kg	5	ND
Dibromobiphenyl	-	mg/kg	5	ND
Tribromobiphenyl	-	mg/kg	5	ND
Tetrabromobiphenyl	-	mg/kg	5	ND
Pentabromobiphenyl	-	mg/kg	5	ND
Hexabromobiphenyl	-	mg/kg	5	ND
Heptabromobiphenyl	-	mg/kg	5	ND
Octabromobiphenyl	-	mg/kg	5	ND
Nonabromobiphenyl	-	mg/kg	5	ND
Decabromobiphenyl	-	mg/kg	5	ND
Sum of PBDEs	1,000	mg/kg	-	ND
Monobromodiphenyl ether	-	mg/kg	5	ND

This document is issued by the Company subject to its General Conditions of Service printed overleaf, available on request or accessible at http://www.sgs.com/terms_and_conditions.htm and, for electronic format documents, subject to Terms and Conditions for Electronic Documents at www.sgs.com/terms_e-document.htm. Attention is drawn to the limitation of liability, indemnification and jurisdiction issues defined therein. Any holder of this document is advised that information contained hereon reflects the Company's findings at the time of its preparation only and within the limits of Client's instructions, if any. The Company's sole responsibility is to its Client and this document does not exonerate parties to a transaction from exercising all their rights and obligations under the transaction documents. This document cannot be reproduced except in full, without prior written approval of the Company. Any unauthorized alteration, forgery or falsification of the content or appearance of this document is unlawful and offenders may be prosecuted to the fullest extent of the law. Unless otherwise stated, the results shown in this test report refer only to the sample(s) tested.

Test Report

No. CANEC1215452305

Date: 20 Nov 2012

Page 4 of 10

<u>Test Item(s)</u>	<u>Limit</u>	<u>Unit</u>	<u>MDL</u>	<u>005</u>
Dibromodiphenyl ether	-	mg/kg	5	ND
Tribromodiphenyl ether	-	mg/kg	5	ND
Tetrabromodiphenyl ether	-	mg/kg	5	ND
Pentabromodiphenyl ether	-	mg/kg	5	ND
Hexabromodiphenyl ether	-	mg/kg	5	ND
Heptabromodiphenyl ether	-	mg/kg	5	ND
Octabromodiphenyl ether	-	mg/kg	5	ND
Nonabromodiphenyl ether	-	mg/kg	5	ND
Decabromodiphenyl ether	-	mg/kg	5	ND

Notes :

- (1) The maximum permissible limit is quoted from the directive 2011/65/EU, Annex II.

Halogen

Test Method : With reference to EN 14582: 2007, analysis was performed by Ion Chromatograph (IC).

<u>Test Item(s)</u>	<u>Unit</u>	<u>MDL</u>	<u>005</u>
Fluorine (F)	mg/kg	50	ND
Chlorine (Cl)	mg/kg	50	ND
Bromine (Br)	mg/kg	50	ND
Iodine (I)	mg/kg	50	ND

Hexabromocyclododecane (HBCDD)

Test Method : Determination of HBCDD by GC-MS based on IEC 62321:2008.

<u>Test Item(s)</u>	<u>Unit</u>	<u>MDL</u>	<u>005</u>
Hexabromocyclododecane (HBCDD)	mg/kg	10	ND

Notes :

- (1) Reference Information: Directive 2011/65/EU recasting RoHS directive 2002/95/EC:
Hexabromocyclododecane (HBCDD) is considered as a priority for risk evaluation and substance restriction.

Phthalate

Test Method : Determination of phthalates by GC-MS based on EN 14372:2004.

This document is issued by the Company subject to its General Conditions of Service printed overleaf, available on request or accessible at http://www.sgs.com/terms_and_conditions.htm and, for electronic format documents, subject to Terms and Conditions for Electronic Documents at www.sgs.com/terms_e-document.htm. Attention is drawn to the limitation of liability, indemnification and jurisdiction issues defined therein. Any holder of this document is advised that information contained hereon reflects the Company's findings at the time of its preparation only and within the limits of Client's instructions, if any. The Company's sole responsibility is to its Client and this document does not exonerate parties to a transaction from exercising all their rights and obligations under the transaction documents. This document cannot be reproduced except in full, without prior written approval of the Company. Any unauthorized alteration, forgery or falsification of the content or appearance of this document is unlawful and offenders may be prosecuted to the fullest extent of the law. Unless otherwise stated, the results shown in this test report refer only to the sample(s) tested.

Test Report

No. CANEC1215452305

Date: 20 Nov 2012

Page 5 of 10

<u>Test Item(s)</u>	<u>Unit</u>	<u>MDL</u>	<u>005</u>
Dibutyl Phthalate (DBP)	% (w/w)	0.003	ND
Benzylbutyl Phthalate (BBP)	% (w/w)	0.003	ND
Bis-(2-ethylhexyl) Phthalate (DEHP)	% (w/w)	0.003	ND

Notes :

- (1) Reference Information: Directive 2011/65/EU recasting RoHS directive 2002/95/EC:
Bis (2-ethylhexyl) phthalate (DEHP), Butyl benzyl phthalate (BBP) and Dibutyl phthalate (DBP) are considered as a priority for risk evaluation and substance restriction.

This document is issued by the Company subject to its General Conditions of Service printed overleaf, available on request or accessible at http://www.sgs.com/terms_and_conditions.htm and, for electronic format documents, subject to Terms and Conditions for Electronic Documents at www.sgs.com/terms_e-document.htm. Attention is drawn to the limitation of liability, indemnification and jurisdiction issues defined therein. Any holder of this document is advised that information contained hereon reflects the Company's findings at the time of its preparation only and within the limits of Client's instructions, if any. The Company's sole responsibility is to its Client and this document does not exonerate parties to a transaction from exercising all their rights and obligations under the transaction documents. This document cannot be reproduced except in full, without prior written approval of the Company. Any unauthorized alteration, forgery or falsification of the content or appearance of this document is unlawful and offenders may be prosecuted to the fullest extent of the law. Unless otherwise stated, the results shown in this test report refer only to the sample(s) tested.

ATTACHMENTS

RoHS Testing Flow Chart

- 1) Name of the person who made testing: Michael Tso / Cutey Yu
- 2) Name of the person in charge of testing: Adams Yu / Yolanda Wei
- 3) These samples were dissolved totally by pre-conditioning method according to below flow chart (Cr⁶⁺ and PBBs/PBDEs test method excluded).

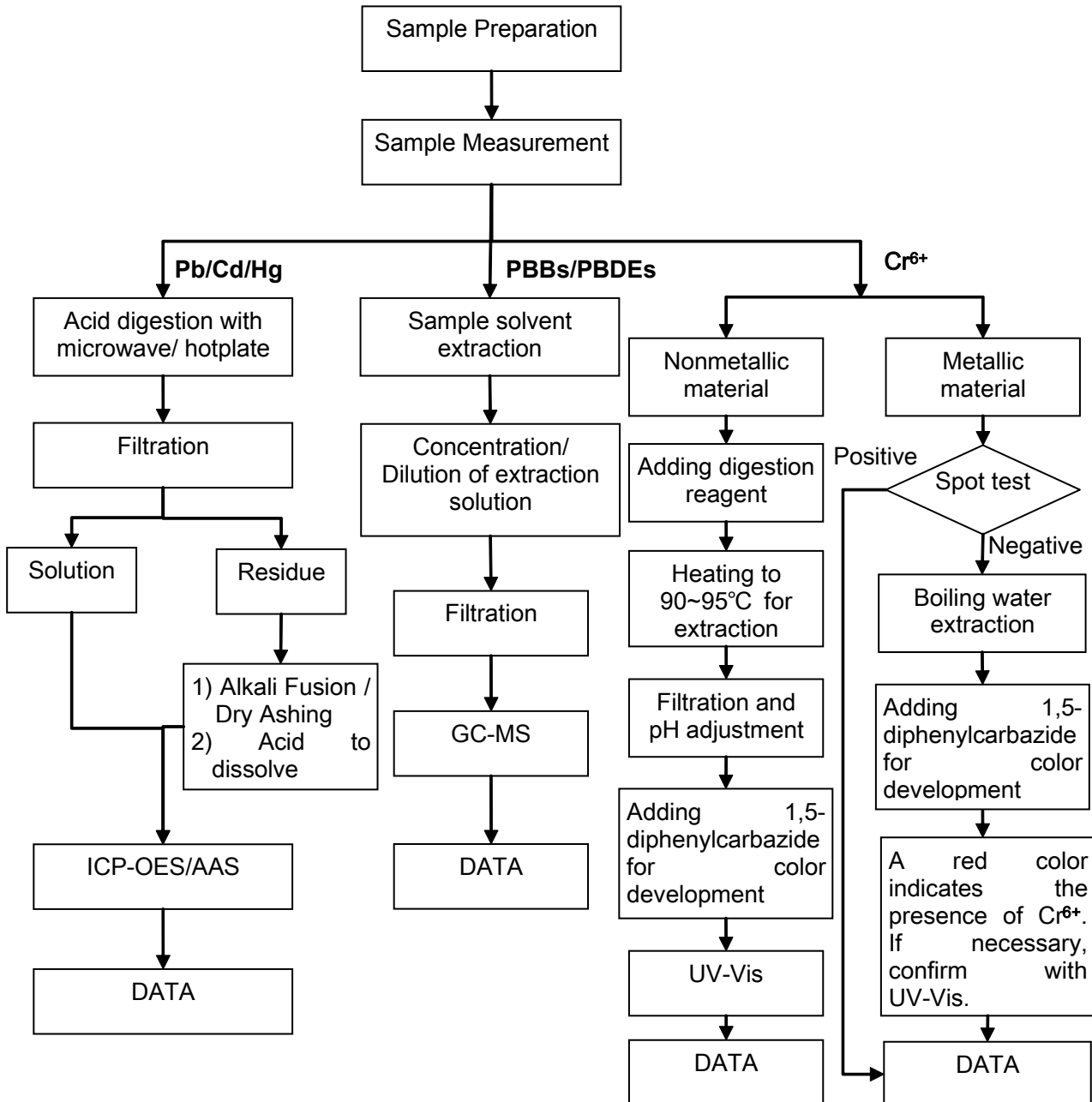

This document is issued by the Company subject to its General Conditions of Service printed overleaf, available on request or accessible at http://www.sgs.com/terms_and_conditions.htm and, for electronic format documents, subject to Terms and Conditions for Electronic Documents at www.sgs.com/terms_e-document.htm. Attention is drawn to the limitation of liability, indemnification and jurisdiction issues defined therein. Any holder of this document is advised that information contained hereon reflects the Company's findings at the time of its preparation only and within the limits of Client's instructions, if any. The Company's sole responsibility is to its Client and this document does not exonerate parties to a transaction from exercising all their rights and obligations under the transaction documents. This document cannot be reproduced except in full, without prior written approval of the Company. Any unauthorized alteration, forgery or falsification of the content or appearance of this document is unlawful and offenders may be prosecuted to the fullest extent of the law. Unless otherwise stated, the results shown in this test report refer only to the sample(s) tested.

ATTACHMENTS

Phthalates Testing Flow Chart

- 1) Name of the person who made testing: Liu Qiong
- 2) Name of the person in charge of testing: Yolanda Wei

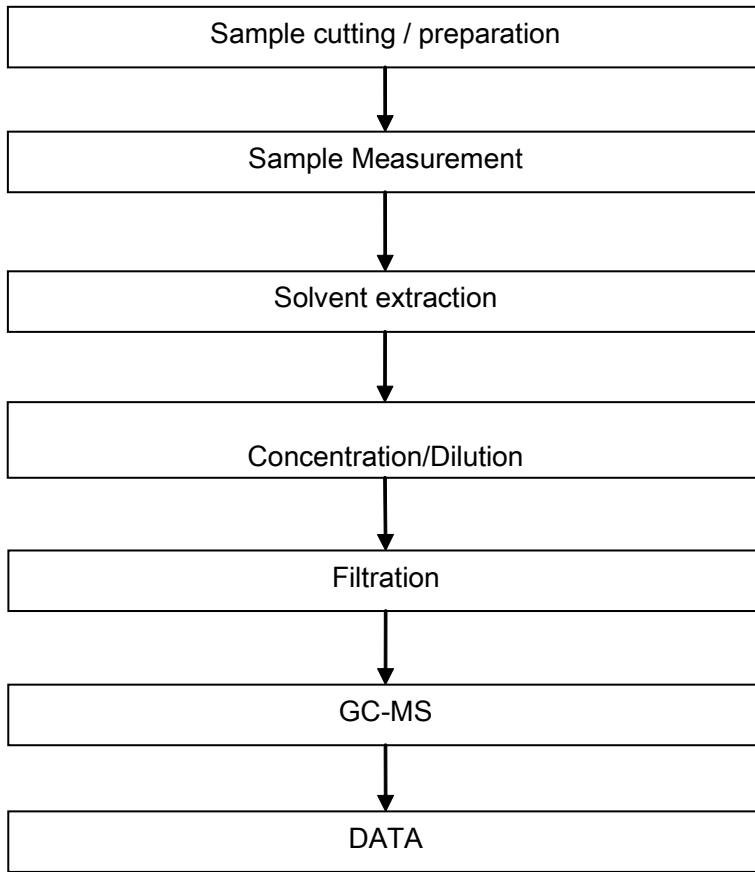

This document is issued by the Company subject to its General Conditions of Service printed overleaf, available on request or accessible at http://www.sgs.com/terms_and_conditions.htm and, for electronic format documents, subject to Terms and Conditions for Electronic Documents at www.sgs.com/terms_e-document.htm. Attention is drawn to the limitation of liability, indemnification and jurisdiction issues defined therein. Any holder of this document is advised that information contained hereon reflects the Company's findings at the time of its preparation only and within the limits of Client's instructions, if any. The Company's sole responsibility is to its Client and this document does not exonerate parties to a transaction from exercising all their rights and obligations under the transaction documents. This document cannot be reproduced except in full, without prior written approval of the Company. Any unauthorized alteration, forgery or falsification of the content or appearance of this document is unlawful and offenders may be prosecuted to the fullest extent of the law. Unless otherwise stated, the results shown in this test report refer only to the sample(s) tested.

ATTACHMENTS

HBCDD Testing Flow Chart

- 1) Name of the person who made testing: Cutey Yu
- 2) Name of the person in charge of testing: Yolanda Wei

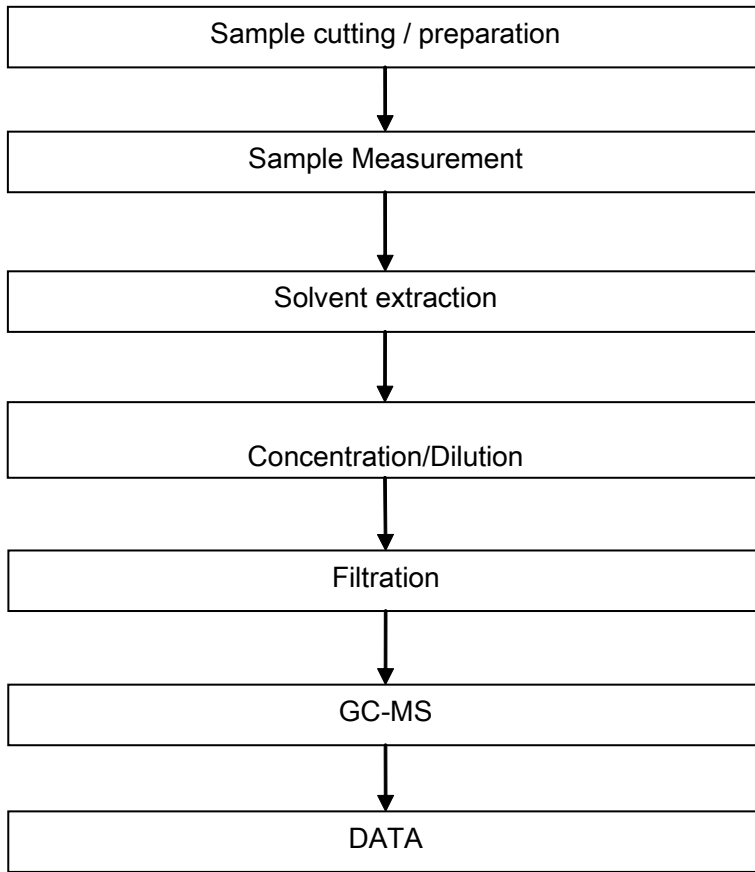

This document is issued by the Company subject to its General Conditions of Service printed overleaf, available on request or accessible at http://www.sgs.com/terms_and_conditions.htm and, for electronic format documents, subject to Terms and Conditions for Electronic Documents at www.sgs.com/terms_e-document.htm. Attention is drawn to the limitation of liability, indemnification and jurisdiction issues defined therein. Any holder of this document is advised that information contained hereon reflects the Company's findings at the time of its preparation only and within the limits of Client's instructions, if any. The Company's sole responsibility is to its Client and this document does not exonerate parties to a transaction from exercising all their rights and obligations under the transaction documents. This document cannot be reproduced except in full, without prior written approval of the Company. Any unauthorized alteration, forgery or falsification of the content or appearance of this document is unlawful and offenders may be prosecuted to the fullest extent of the law. Unless otherwise stated, the results shown in this test report refer only to the sample(s) tested.

ATTACHMENTS

Halogen Testing Flow Chart

- 1) Name of the person who made testing: Bella Wang
- 2) Name of the person in charge of testing: Adams Yu

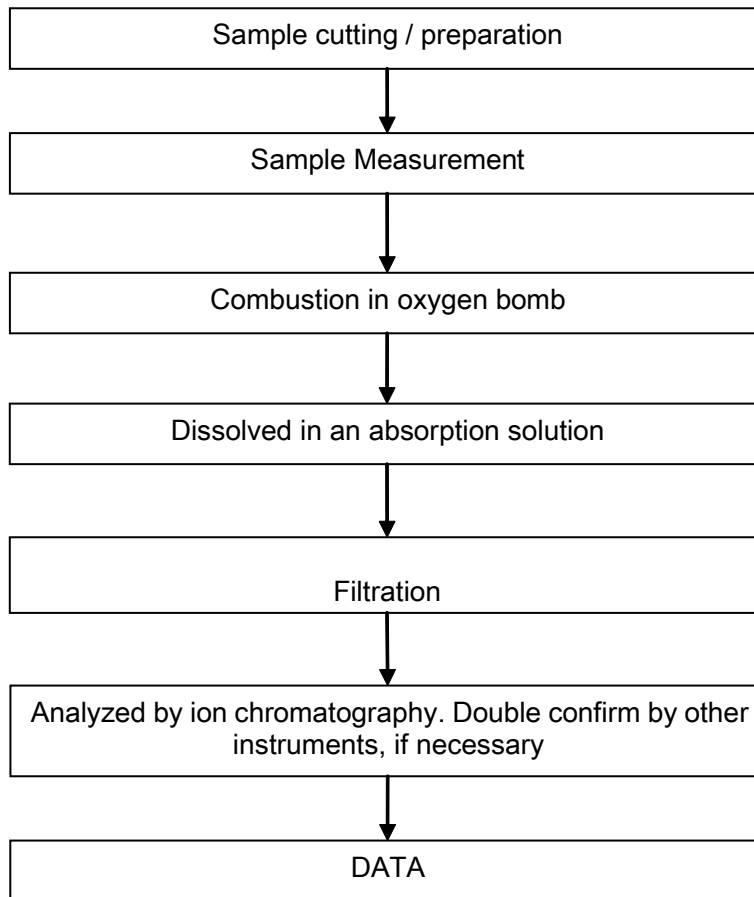

This document is issued by the Company subject to its General Conditions of Service printed overleaf, available on request or accessible at http://www.sgs.com/terms_and_conditions.htm and, for electronic format documents, subject to Terms and Conditions for Electronic Documents at www.sgs.com/terms_e-document.htm. Attention is drawn to the limitation of liability, indemnification and jurisdiction issues defined therein. Any holder of this document is advised that information contained hereon reflects the Company's findings at the time of its preparation only and within the limits of Client's instructions, if any. The Company's sole responsibility is to its Client and this document does not exonerate parties to a transaction from exercising all their rights and obligations under the transaction documents. This document cannot be reproduced except in full, without prior written approval of the Company. Any unauthorized alteration, forgery or falsification of the content or appearance of this document is unlawful and offenders may be prosecuted to the fullest extent of the law. Unless otherwise stated, the results shown in this test report refer only to the sample(s) tested.

Test Report

Report No. RLSZF001577440003

Page 1 of 6

Applicant DONGGUAN SUNWAY PRINTING INDUSTRY CO.,LTD
Address YINLING INDUSTRIAL, XIAQIAO GUANLONG ROAD, DONGCHENG ZONE,
DONGGUAN CITY, GUANGDONG PROVINCE, CHINA

The following sample(s) and sample information was/were submitted and identified by/on the behalf of the client

Sample Name INK
Part No. 新宝龙黑
Color Black
Material INK
Manufacturer 深日
Sample Received Date Feb. 2, 2013
Testing Period Feb. 2, 2013 to Feb. 6, 2013

Test Requested As specified by client, to test Lead(Pb), Cadmium(Cd), Mercury(Hg), Hexavalent Chromium(Cr(VI)), Polybrominated Biphenyls(PBBs), Polybrominated Diphenyl Ethers(PBDEs), Fluorine(F), Chlorine(Cl), Bromine(Br), Iodine(I), Hexabromocyclododecane(HBCDD), Phthalates in the submitted sample(s).

Test Method Please refer to the following page(s).

Test Result(s) Please refer to the following page(s).

Tested by

Rick Li

Reviewed by

Vargas He

Approved by

Danny Liu

Date

Feb. 6, 2013

Danny Liu

Technical Manager

No. 14465604

Centre Testing International (Shenzhen) Co., Ltd. Hongwei Industrial Zone, Bao'an 70 District, Shenzhen, Guangdong, China

Test Report

Report No. RLSZF001577440003

Page 2 of 6

Test Method

Test Item(s)	Test Method	Measured Equipment(s)	MDL
Lead(Pb)	IEC 62321:2008 Ed.1 Sec.10	ICP-OES	2 mg/kg
Cadmium(Cd)	IEC 62321:2008 Ed.1 Sec.10	ICP-OES	2 mg/kg
Mercury(Hg)	IEC 62321:2008 Ed.1 Sec.7	ICP-OES	2 mg/kg
Hexavalent Chromium(Cr(VI))	IEC 62321:2008 Ed.1 Annex C	UV-Vis	2 mg/kg
Polybrominated Biphenyls(PBBs)	IEC 62321:2008 Ed.1 Annex A	GC-MS	5 mg/kg
Polybrominated Diphenyl Ethers(PBDEs)	IEC 62321:2008 Ed.1 Annex A	GC-MS	5 mg/kg
Fluorine(F)	Refer to BS EN 14582:2007	IC	10 mg/kg
Chlorine(Cl)	Refer to BS EN 14582:2007	IC	10 mg/kg
Bromine(Br)	Refer to BS EN 14582:2007	IC	10 mg/kg
Iodine(I)	Refer to BS EN 14582:2007	IC	10 mg/kg
Phthalates	Refer to EN 14372:2004	GC-MS	50 mg/kg
Hexabromocyclododecane(HBCDD)	Refer to US EPA 3540C:1996	GC-MS	5 mg/kg

Test Result(s)

Tested Item(s)	Result
Lead(Pb)	N.D.
Cadmium (Cd)	N.D.
Mercury(Hg)	N.D.
Hexavalent Chromium(Cr(VI))	N.D.

Tested Item(s)	Result
Polybrominated Biphenyls(PBBs)	
Monobromobiphenyl	N.D.
Dibromobiphenyl	N.D.
Tribromobiphenyl	N.D.
Tetrabromobiphenyl	N.D.
Pentabromobiphenyl	N.D.
Hexabromobiphenyl	N.D.
Heptabromobiphenyl	N.D.
Octabromobiphenyl	N.D.
Nonabromobiphenyl	N.D.
Decabromobiphenyl	N.D.

Test Report

Report No. RLSZF001577440003

Page 3 of 6

Tested Item(s)	Result
Polybrominated Diphenyl Ethers(PBDEs)	
Monobromodiphenyl ether	N.D.
Dibromodiphenyl ether	N.D.
Tribromodiphenyl ether	N.D.
Tetrabromodiphenyl ether	N.D.
Pentabromodiphenyl ether	N.D.
Hexabromodiphenyl ether	N.D.
Heptabromodiphenyl ether	N.D.
Octabromodiphenyl ether	N.D.
Nonabromodiphenyl ether	N.D.
Decabromodiphenyl ether	N.D.

Tested Item(s)	Result
Halogen(s)	
Fluorine (F)	994 mg/kg
Chlorine (Cl)	251 mg/kg
Bromine (Br)	N.D.
Iodine (I)	N.D.

Tested Item(s)	Result
Hexabromocyclododecane (HBCDD)	N.D.

Tested Item(s)	CAS No.	EC No.	Result
Phthalates			
Diisobutyl phthalate(DIBP)	84-69-5	201-553-2	N.D.
Dibutyl phthalate(DBP)	84-74-2	201-557-4	N.D.
Butylbenzyl phthalate(BBP)	85-68-7	201-622-7	N.D.
Di-2-ethylhexyl phthalate(DEHP)	117-81-7	204-211-0	N.D.
Di-n-octyl phthalate(DNOP)	117-84-0	204-214-7	N.D.
Diisononyl phthalate(DINP)	28553-12-0	249-079-5	N.D.
Diisodecyl phthalate(DIDP)	26761-40-0	247-977-1	N.D.
Di-n-hexyl phthalate (DNHP)	84-75-3	201-559-5	N.D.
Dimethoxyethyl phthalate (DMEP)	117-82-8	204-212-6	N.D.

Tested Sample/Part Description Black ink

Note: **The sample(s) had been dissolved totally tested for Lead, Cadmium, Mercury.**

- MDL = Method Detection Limit
- N.D. = Not Detected (<MDL)
- mg/kg = ppm = parts per million

Test Report

Report No. RLSZF001577440003

Page 4 of 6

Test Process

1. Lead(Pb), Cadmium(Cd)

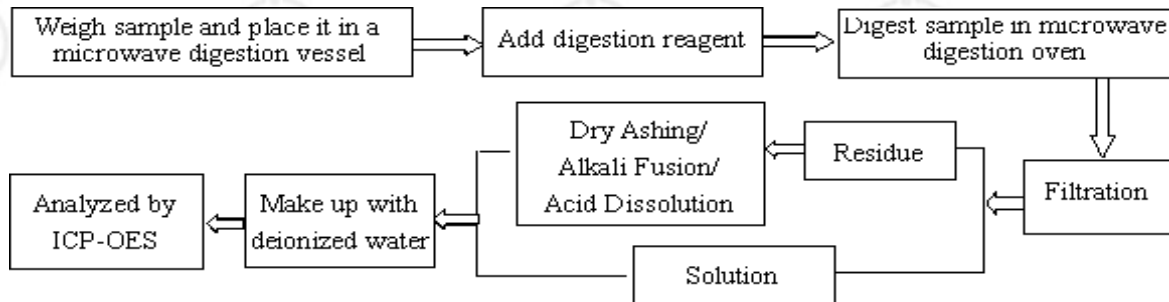

2. Mercury(Hg)

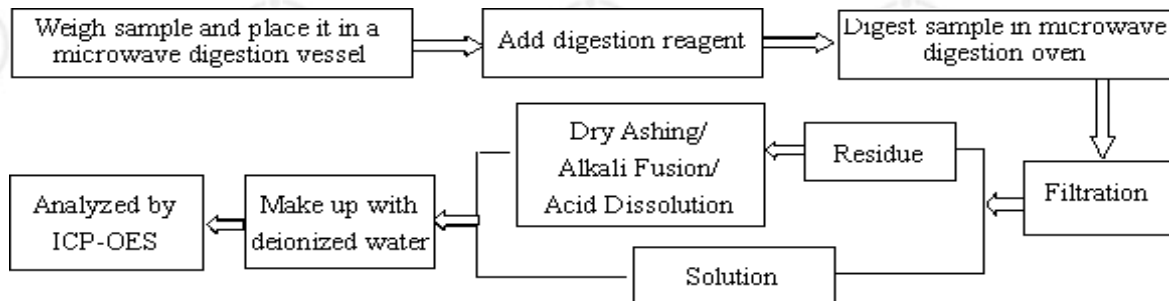

3. Hexavalent Chromium(Cr(VI))

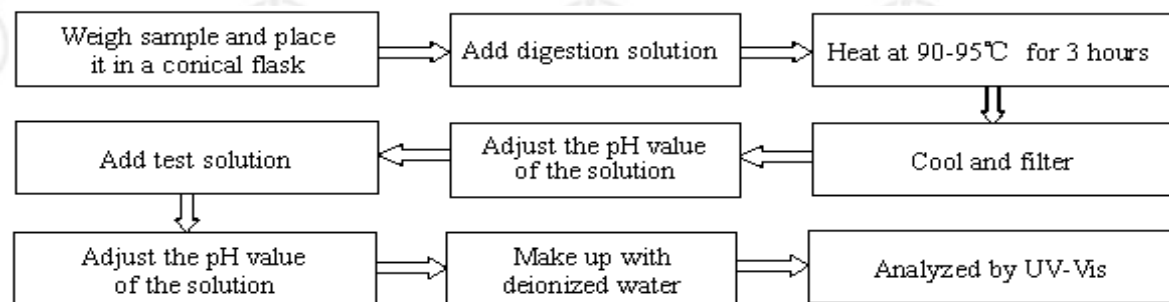

4. Phthalates

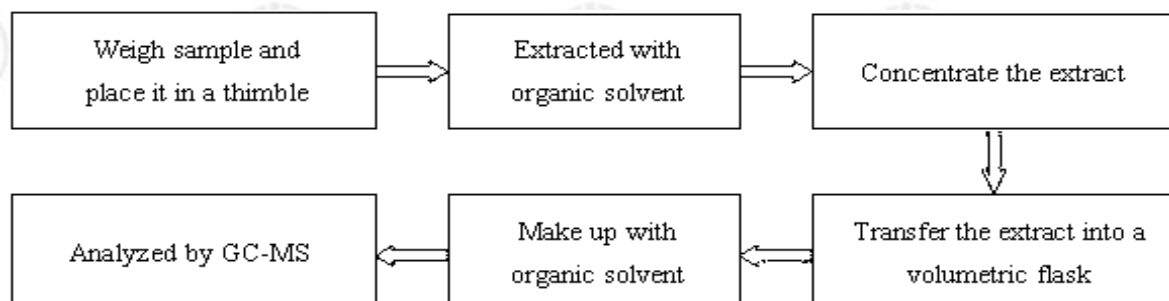

Test Report

Report No. RLSZF001577440003

Page 5 of 6

5. Polybrominated Biphenyls(PBBs), Polybrominated Diphenyl Ethers(PBDEs)

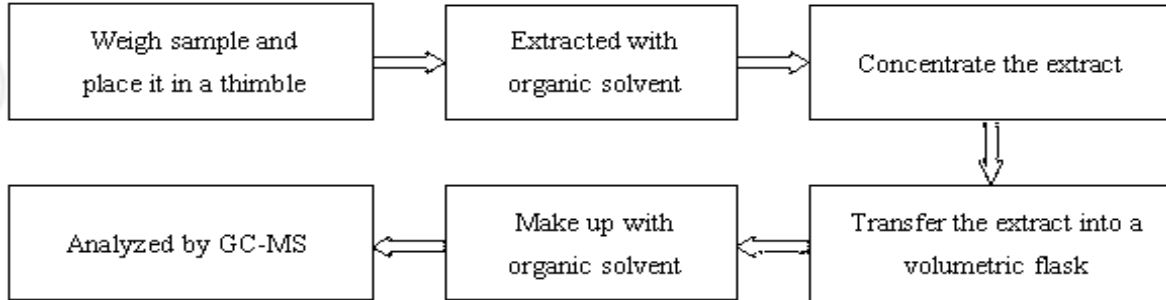

6. Hexabromocyclododecane(HBCDD)

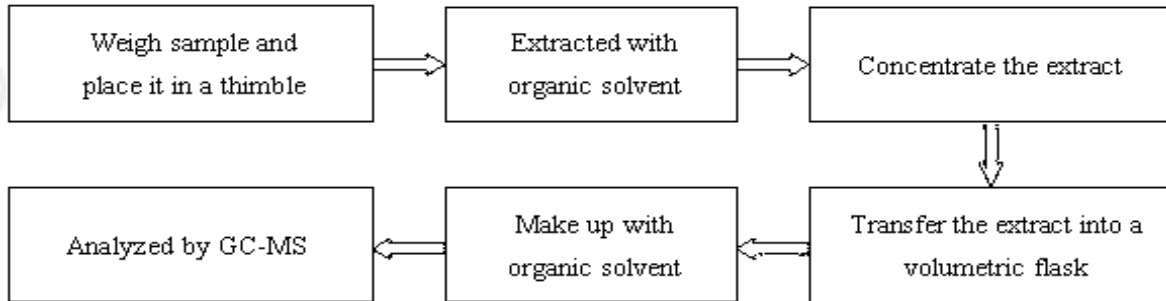

7. Fluorine(F), Chlorine(Cl), Bromine(Br), Iodine(I)

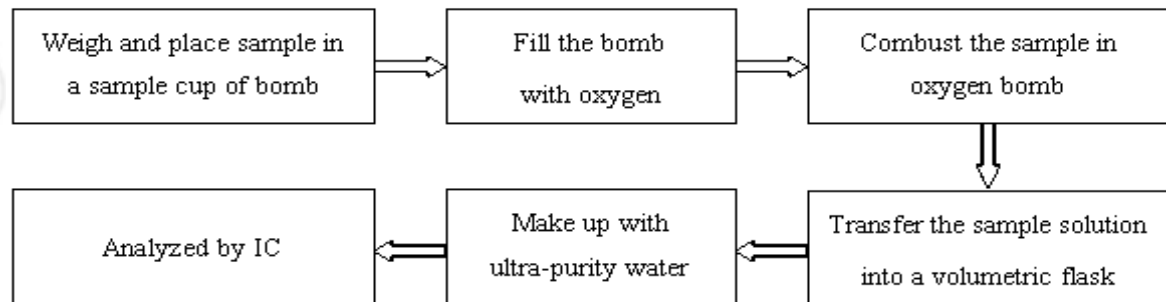

Test Report

Report No. RLSZF001577440003

Page 6 of 6

Photo(s) of the sample(s)



*** End of report ***

The test report is effective only with both signature and specialized stamp. The result(s) shown in this report refer only to the sample(s) tested. Without written approval of CTI, this report can't be reproduced except in full.

測試報告 Test Report

號碼(No.) : CE/2012/93387

日期(Date) : 2012/09/24

頁數(Page): 1 of 6

喬越實業有限公司

SIL-MORE INDUSTRIAL LTD.

新北市三重區興德路100號16樓

16F, NO. 100, XINGDE RD., SANCHONG DISTRICT, NEW TAIPEI CITY 24158, TAIWAN



以下測試樣品係由客戶送樣，且由客戶聲稱並經客戶確認如下 (The following samples was/were submitted and identified by/on behalf of the client as):

樣品名稱(Sample Description) : DOW CORNING TC-1996 THERMALLY CONDUCTIVE COMPOUND
收件日期(Sample Receiving Date) : 2012/09/18
測試期間(Testing Period) : 2012/09/18 TO 2012/09/24

=====
測試需求(Test Requested) : 依據客戶要求，參考RoHS 2011/65/EU Annex II 指令進行鎘，鉛，汞，六價鉻，多溴聯苯，多溴聯苯醚測試。(As specified by client, with reference to RoHS Directive 2011/65/EU Annex II to determine Cadmium, Lead, Mercury, Cr(VI), PBBs, PBDEs contents in the submitted sample.)

測試方法(Test Method) : 參考IEC 62321: 2008方法 / With reference to IEC 62321: 2008.

測試結果(Test Results) : 請見下一頁 (Please refer to next pages).

Chenyu Kung / Operation Manager
Signed for and on behalf of
SGS TAIWAN LTD.
Chemical Laboratory – Taipei

Unless otherwise stated the results shown in this test report refer only to the sample(s) tested. This test report cannot be reproduced, except in full, without prior written permission of the Company.除非另有說明，此報告結果僅對測試之樣品負責。本報告未經本公司書面許可，不可部分複製。
This document is issued by the Company subject to its General Conditions of Service printed overleaf, available on request or accessible at www.sgs.com/terms_and_conditions.htm and, for electronic format documents, subject to Terms and Conditions for Electronic Documents at www.sgs.com/en/Terms-and-Conditions/Terms-e-Documents. Attention is drawn to the limitation of liability, indemnification and jurisdiction issues defined therein. Any holder of this document is advised that information contained hereon reflects the Company's findings at the time of its intervention only and within the limits of Client's instructions, if any. The Company's sole responsibility is to its Client and this document does not exonerate parties to a transaction from exercising all their rights and obligations under the transaction documents. This document cannot be reproduced except in full, without prior written approval of the Company. Any unauthorized alteration, forgery or falsification of the content or appearance of this document is unlawful and offenders may be prosecuted to the fullest extent of the law.

測試報告 Test Report

號碼(No.) : CE/2012/93387

日期(Date) : 2012/09/24

頁數(Page): 2 of 6

喬越實業有限公司

SIL-MORE INDUSTRIAL LTD.

新北市三重區興德路100號16樓

16F, NO. 100, XINGDE RD., SANCHONG DISTRICT, NEW TAIPEI CITY 24158, TAIWAN



測試結果(Test Results)

測試部位(PART NAME)No.1 : 灰色膏狀 (GRAY PASTE)

測試項目 (Test Items)	單位 (Unit)	測試方法 (Method)	方法偵測 極限值 (MDL)	結果 (Result)
				No.1
鎘 / Cadmium (Cd)	mg/kg	參考IEC 62321: 2008方法, 以感應耦合電漿原子發射光譜儀檢測. / With reference to IEC 62321: 2008 and performed by ICP-AES.	2	n.d.
鉛 / Lead (Pb)	mg/kg		2	n.d.
汞 / Mercury (Hg)	mg/kg		2	n.d.
六價鉻 / Hexavalent Chromium Cr(VI)	mg/kg	參考IEC 62321: 2008方法, 以UV-VIS檢測. / With reference to IEC 62321: 2008 and performed by UV-VIS.	2	n.d.
多溴聯苯總和 / Sum of PBBs	mg/kg	參考IEC 62321: 2008方法, 以氣相層析/質譜儀檢測. / With reference to IEC 62321: 2008 and performed by GC/MS.	-	n.d.
一溴聯苯 / Monobromobiphenyl	mg/kg		5	n.d.
二溴聯苯 / Dibromobiphenyl	mg/kg		5	n.d.
三溴聯苯 / Tribromobiphenyl	mg/kg		5	n.d.
四溴聯苯 / Tetrabromobiphenyl	mg/kg		5	n.d.
五溴聯苯 / Pentabromobiphenyl	mg/kg		5	n.d.
六溴聯苯 / Hexabromobiphenyl	mg/kg		5	n.d.
七溴聯苯 / Heptabromobiphenyl	mg/kg		5	n.d.
八溴聯苯 / Octabromobiphenyl	mg/kg		5	n.d.
九溴聯苯 / Nonabromobiphenyl	mg/kg		5	n.d.
十溴聯苯 / Decabromobiphenyl	mg/kg	5	n.d.	

Unless otherwise stated the results shown in this test report refer only to the sample(s) tested. This test report cannot be reproduced, except in full, without prior written permission of the Company.除非另有說明, 此報告結果僅對測試之樣品負責。本報告未經本公司書面許可, 不可部分複製。
This document is issued by the Company subject to its General Conditions of Service printed overleaf, available on request or accessible at www.sgs.com/terms_and_conditions.htm and, for electronic format documents, subject to Terms and Conditions for Electronic Documents at www.sgs.com/en/Terms-and-Conditions/Terms-e-Documents. Attention is drawn to the limitation of liability, indemnification and jurisdiction issues defined therein. Any holder of this document is advised that information contained hereon reflects the Company's findings at the time of its intervention only and within the limits of Client's instructions, if any. The Company's sole responsibility is to its Client and this document does not exonerate parties to a transaction from exercising all their rights and obligations under the transaction documents. This document cannot be reproduced except in full, without prior written approval of the Company. Any unauthorized alteration, forgery or falsification of the content or appearance of this document is unlawful and offenders may be prosecuted to the fullest extent of the law.

測試報告 Test Report

號碼(No.) : CE/2012/93387

日期(Date) : 2012/09/24

頁數(Page): 3 of 6

喬越實業有限公司

SIL-MORE INDUSTRIAL LTD.

新北市三重區興德路100號16樓

16F, NO. 100, XINGDE RD., SANCHONG DISTRICT, NEW TAIPEI CITY 24158, TAIWAN



測試項目 (Test Items)	單位 (Unit)	測試方法 (Method)	方法偵測 極限值 (MDL)	結果 (Result)
				No.1
多溴聯苯醚總和 / Sum of PBDEs	mg/kg	參考IEC 62321: 2008方法, 以氣相層析/質譜儀檢測. / With reference to IEC 62321: 2008 and performed by GC/MS.	-	n.d.
一溴聯苯醚 / Monobromodiphenyl ether	mg/kg		5	n.d.
二溴聯苯醚 / Dibromodiphenyl ether	mg/kg		5	n.d.
三溴聯苯醚 / Tribromodiphenyl ether	mg/kg		5	n.d.
四溴聯苯醚 / Tetrabromodiphenyl ether	mg/kg		5	n.d.
五溴聯苯醚 / Pentabromodiphenyl ether	mg/kg		5	n.d.
六溴聯苯醚 / Hexabromodiphenyl ether	mg/kg		5	n.d.
七溴聯苯醚 / Heptabromodiphenyl ether	mg/kg		5	n.d.
八溴聯苯醚 / Octabromodiphenyl ether	mg/kg		5	n.d.
九溴聯苯醚 / Nonabromodiphenyl ether	mg/kg		5	n.d.
十溴聯苯醚 / Decabromodiphenyl ether	mg/kg	5	n.d.	

備註(Note) :

1. mg/kg = ppm ; 0.1wt% = 1000ppm
2. n.d. = Not Detected (未檢出)
3. MDL = Method Detection Limit (方法偵測極限值)
4. "-" = Not Regulated (無規格值)

Unless otherwise stated the results shown in this test report refer only to the sample(s) tested. This test report cannot be reproduced, except in full, without prior written permission of the Company. 除非另有說明, 此報告結果僅對測試之樣品負責。本報告未經本公司書面許可, 不可部分複製。
This document is issued by the Company subject to its General Conditions of Service printed overleaf, available on request or accessible at www.sgs.com/terms_and_conditions.htm and, for electronic format documents, subject to Terms and Conditions for Electronic Documents at www.sgs.com/en/Terms-and-Conditions/Terms-e-Document. Attention is drawn to the limitation of liability, indemnification and jurisdiction issues defined therein. Any holder of this document is advised that information contained hereon reflects the Company's findings at the time of its intervention only and within the limits of Client's instructions, if any. The Company's sole responsibility is to its Client and this document does not exonerate parties to a transaction from exercising all their rights and obligations under the transaction documents. This document cannot be reproduced except in full, without prior written approval of the Company. Any unauthorized alteration, forgery or falsification of the content or appearance of this document is unlawful and offenders may be prosecuted to the fullest extent of the law.

測試報告 Test Report

號碼(No.) : CE/2012/93387

日期(Date) : 2012/09/24

頁數(Page): 4 of 6

喬越實業有限公司

SIL-MORE INDUSTRIAL LTD.

新北市三重區興德路100號16樓

16F, NO. 100, XINGDE RD., SANCHONG DISTRICT, NEW TAIPEI CITY 24158, TAIWAN



- 1) 根據以下的流程圖之條件，樣品已完全溶解。(六價鉻測試方法除外) / These samples were dissolved totally by pre-conditioning method according to below flow chart. (Cr⁶⁺ test method excluded)
- 2) 測試人員：楊登偉 / Name of the person who made measurement: Climbgreat Yang
- 3) 測試負責人：張啓興 / Name of the person in charge of measurement: Troy Chang

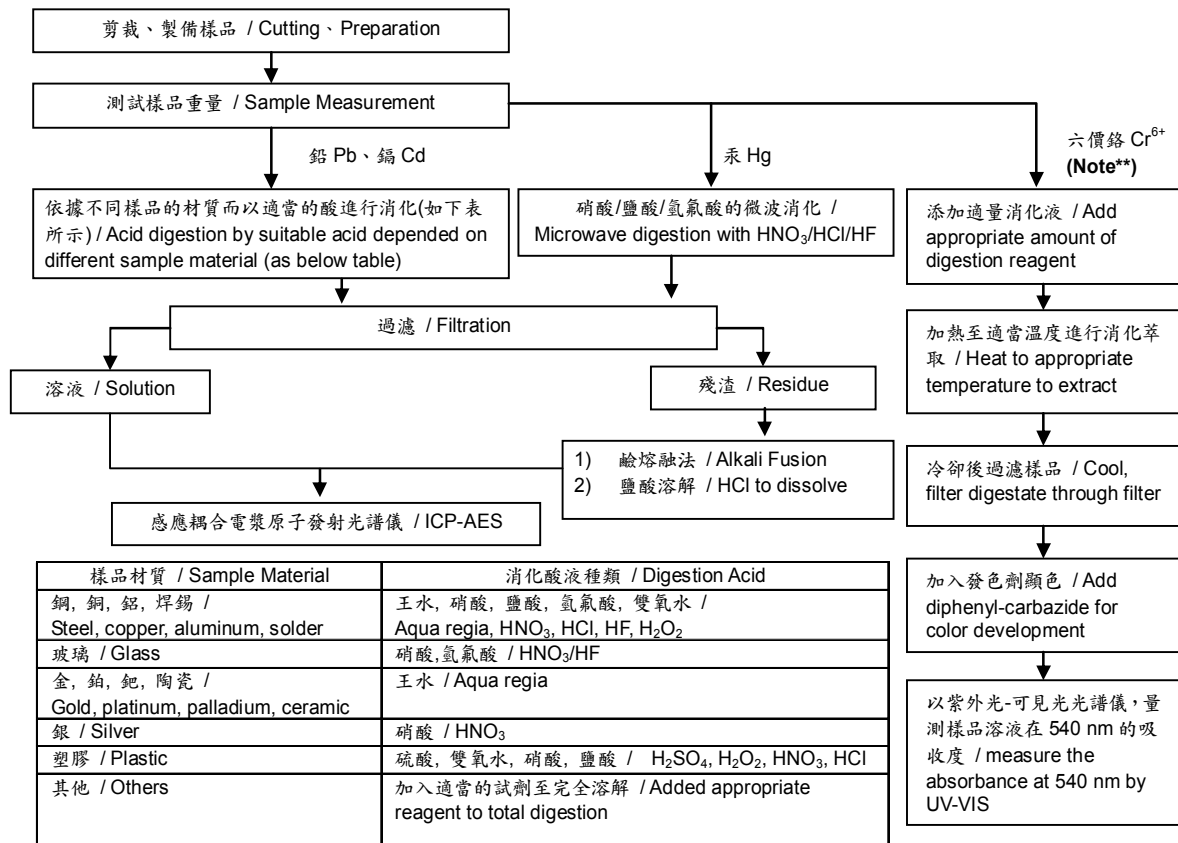

Note:** (1) 針對非金屬材料加入鹼性消化液, 加熱至 90~95°C 萃取。 / For non-metallic material, add alkaline digestion reagent and heat to 90~95°C.
 (2) 針對金屬材料加入純水, 加熱至沸騰萃取。 / For metallic material, add pure water and heat to boiling.

Unless otherwise stated the results shown in this test report refer only to the sample(s) tested. This test report cannot be reproduced, except in full, without prior written permission of the Company. 除非另有說明, 此報告結果僅對測試之樣品負責。本報告未經本公司書面許可, 不可部分複製。
 This document is issued by the Company subject to its General Conditions of Service printed overleaf, available on request or accessible at www.sgs.com/terms_and_conditions.htm and, for electronic format documents, subject to Terms and Conditions for Electronic Documents at www.sgs.com/en/Terms-and-Conditions/Terms-e-Document. Attention is drawn to the limitation of liability, indemnification and jurisdiction issues defined therein. Any holder of this document is advised that information contained hereon reflects the Company's findings at the time of its intervention only and within the limits of Client's instructions, if any. The Company's sole responsibility is to its Client and this document does not exonerate parties to a transaction from exercising all their rights and obligations under the transaction documents. This document cannot be reproduced except in full, without prior written approval of the Company. Any unauthorized alteration, forgery or falsification of the content or appearance of this document is unlawful and offenders may be prosecuted to the fullest extent of the law.

測試報告 Test Report

號碼(No.) : CE/2012/93387

日期(Date) : 2012/09/24

頁數(Page): 5 of 6

喬越實業有限公司

SIL-MORE INDUSTRIAL LTD.

新北市三重區興德路100號16樓

16F, NO. 100, XINGDE RD., SANCHONG DISTRICT, NEW TAIPEI CITY 24158, TAIWAN



多溴聯苯/多溴聯苯醚分析流程圖 / PBB/PBDE analytical FLOW CHART

- 測試人員：翁賜彬 / Name of the person who made measurement: Roman Wong
- 測試負責人：張啓興 / Name of the person in charge of measurement: Troy Chang

初次測試程序 / First testing process —————>

選擇性篩檢程序 / Optional screen process>

確認程序 / Confirmation process - - ->

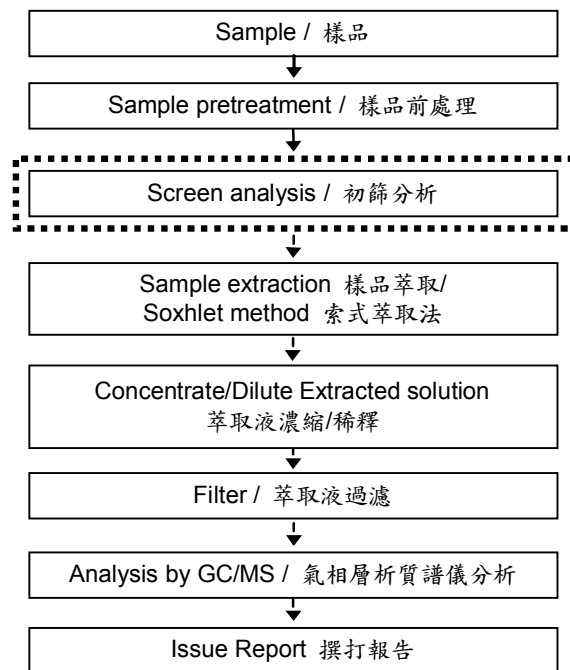

Unless otherwise stated the results shown in this test report refer only to the sample(s) tested. This test report cannot be reproduced, except in full, without prior written permission of the Company. 除非另有說明，此報告結果僅對測試之樣品負責。本報告未經本公司書面許可，不可部分複製。
This document is issued by the Company subject to its General Conditions of Service printed overleaf, available on request or accessible at www.sgs.com/terms_and_conditions.htm and, for electronic format documents, subject to Terms and Conditions for Electronic Documents at www.sgs.com/en/Terms-and-Conditions/Terms-e-Documents. Attention is drawn to the limitation of liability, indemnification and jurisdiction issues defined therein. Any holder of this document is advised that information contained hereon reflects the Company's findings at the time of its intervention only and within the limits of Client's instructions, if any. The Company's sole responsibility is to its Client and this document does not exonerate parties to a transaction from exercising all their rights and obligations under the transaction documents. This document cannot be reproduced except in full, without prior written approval of the Company. Any unauthorized alteration, forgery or falsification of the content or appearance of this document is unlawful and offenders may be prosecuted to the fullest extent of the law.

測試報告 Test Report

號碼(No.) : CE/2012/93387

日期(Date) : 2012/09/24

頁數(Page): 6 of 6

喬越實業有限公司

SIL-MORE INDUSTRIAL LTD.

新北市三重區興德路100號16樓

16F, NO. 100, XINGDE RD., SANCHONG DISTRICT, NEW TAIPEI CITY 24158, TAIWAN



* 照片中如有箭頭標示，則表示為實際檢測之樣品/部位。 *
(The tested sample / part is marked by an arrow if it's shown on the photo.)

CE/2012/93387

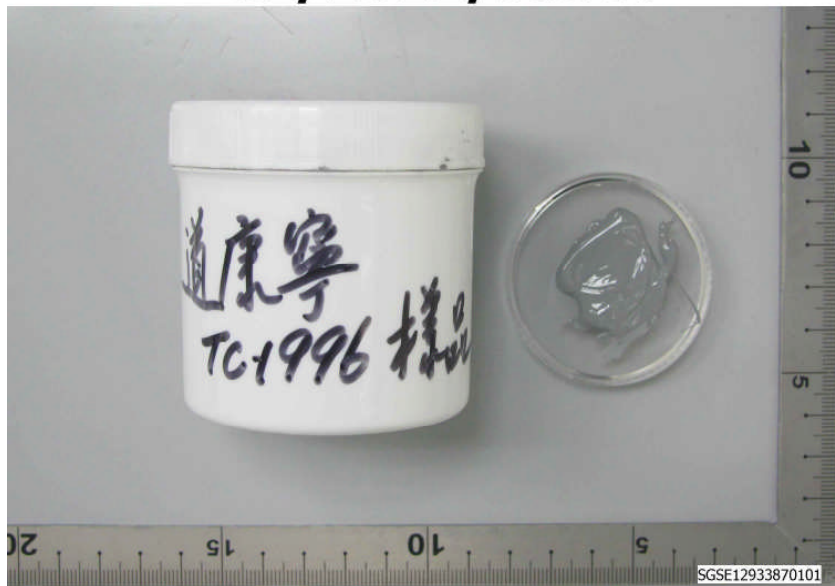

** 報告結尾 (End of Report) **

Unless otherwise stated the results shown in this test report refer only to the sample(s) tested. This test report cannot be reproduced, except in full, without prior written permission of the Company. 除非另有說明，此報告結果僅對測試之樣品負責。本報告未經本公司書面許可，不可部分複製。
This document is issued by the Company subject to its General Conditions of Service printed overleaf, available on request or accessible at www.sgs.com/terms_and_conditions.htm and, for electronic format documents, subject to Terms and Conditions for Electronic Documents at www.sgs.com/en/Terms-and-Conditions/Terms-e-Documents. Attention is drawn to the limitation of liability, indemnification and jurisdiction issues defined therein. Any holder of this document is advised that information contained hereon reflects the Company's findings at the time of its intervention only and within the limits of Client's instructions, if any. The Company's sole responsibility is to its Client and this document does not exonerate parties to a transaction from exercising all their rights and obligations under the transaction documents. This document cannot be reproduced except in full, without prior written approval of the Company. Any unauthorized alteration, forgery or falsification of the content or appearance of this document is unlawful and offenders may be prosecuted to the fullest extent of the law.