

THIS DRAWING IS UNPUBLISHED. RELEASED FOR PUBLICATION
 © COPYRIGHT - By - ALL RIGHTS RESERVED.

LOC		DIST		REVISIONS			
P	LTR	DESCRIPTION		DATE	DWN	APVD	
	T	REVISED PER ECO-14-012828		30AUG2014	MGM	CT	

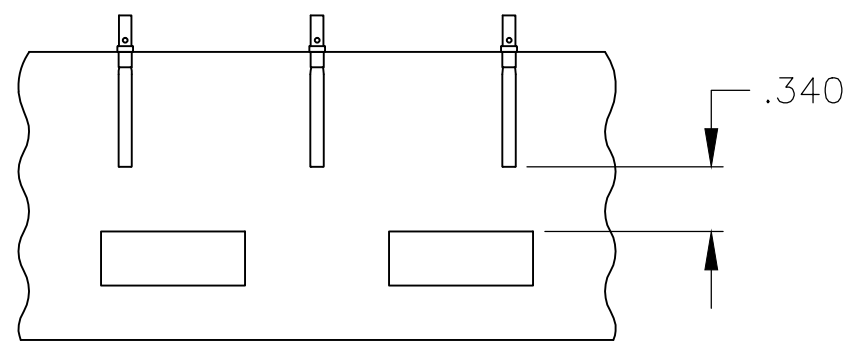

DETAIL A
 TAPE MOUNTED
 ASSEMBLY
 SCALE 1:1
 205116-2 ONLY

- WHEN ORDERING CONTACT ON TAPE, ORDER BY THE TAPE NUMBER PLUS THE PACKAGING CODE AS FOLLOWS:
 - FOR USE WITH AMP TAPETRONIC, PNEUMATIC TOOL-
 - 1000 PARTS TO A BOX ADD PACKAGING CODE: 1MBOX
 - FOR USE WITH 4/8 INDENT STRIPPER CRIMPER-
 - 1000 PARTS TO A REEL ADD PACKAGING CODE: 1MREEL
 - 5000 PARTS TO A REEL ADD PACKAGING CODE: 5MREEL
- POINT OF PLATING THICKNESS MEASUREMENT .100/.150 FROM WIRE BARREL END ON EXTERIOR.
- MANUFACTURER'S LOGO ("A" OR "-.") LOCATION OPTIONAL.

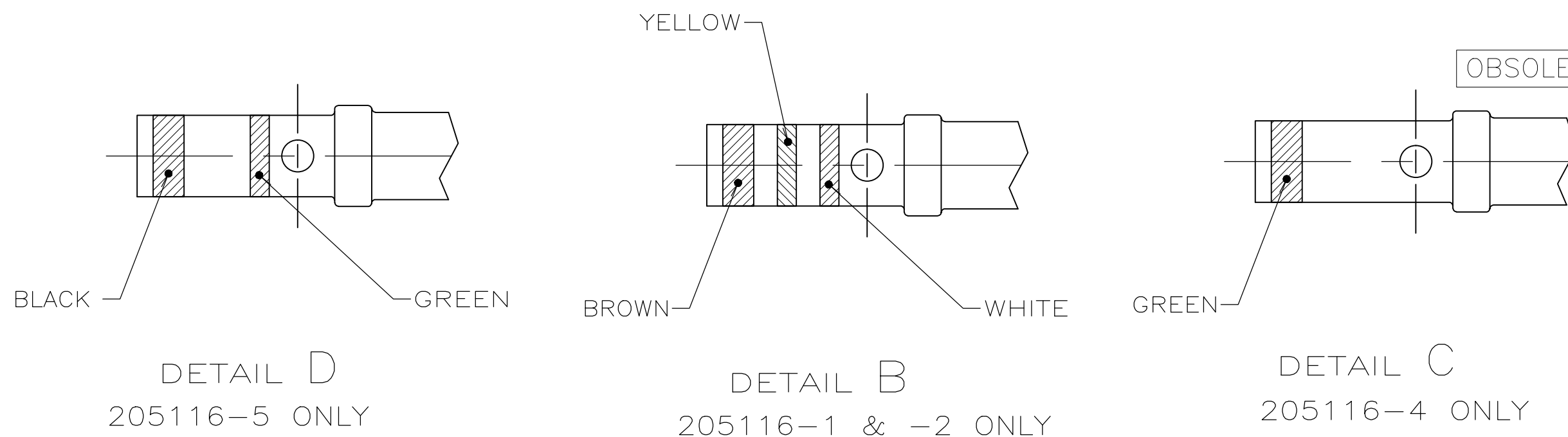
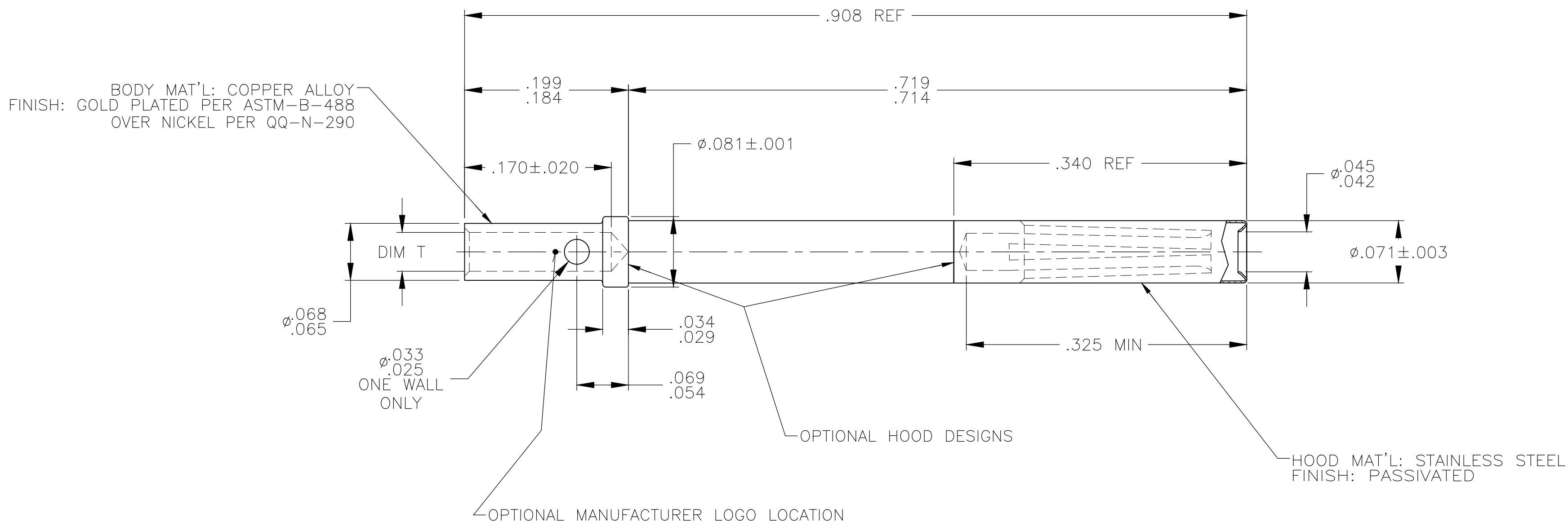

WIRE GAGE	REMARKS	DIM T	PART NUMBER
30 - 26	SEE DETAIL D	ø.023-.025	205116-5
24 - 20	SEE DETAIL C	ø.043-.046	205116-4
24 - 20	NO COLOR CODE	ø.043-.046	205116-3
24 - 20	SEE DETAIL A & B	ø.043-.046	205116-2
24 - 20	SEE DETAIL B	ø.043-.046	205116-1

THIS DRAWING IS A CONTROLLED DOCUMENT. DIMENSIONING AND TOLERANCING PER ASME Y14.5M (ISO STANDARDS)		DWN C.C.THOMAS 2-12-04	STE TE Connectivity	
DIMENSIONS: INCHES		CHK LARRY OH 2-12-04		
TOLERANCES UNLESS OTHERWISE SPECIFIED:		APVD LARRY OH 2-12-04	NAME SOCKET ASSEMBLY,SUB 20,TYPE XVII-RM	
0 PLC ± -	1 PLC ± -	PRODUCT SPEC	-	
2 PLC ± -	3 PLC ± .005	APPLICATION SPEC	-	
4 PLC ± -	ANGLES ± 2°	WEIGHT -	SIZE A2	CAGE CODE 00779
MATERIAL SEE CALLOUTS	FINISH SEE CALLOUTS	CUSTOMER DRAWING	DRAWING NO C-205116	RESTRICTED TO -
SCALE 10:1			SHEET 1 OF 1	REV T