

6

5

4

3

2

1

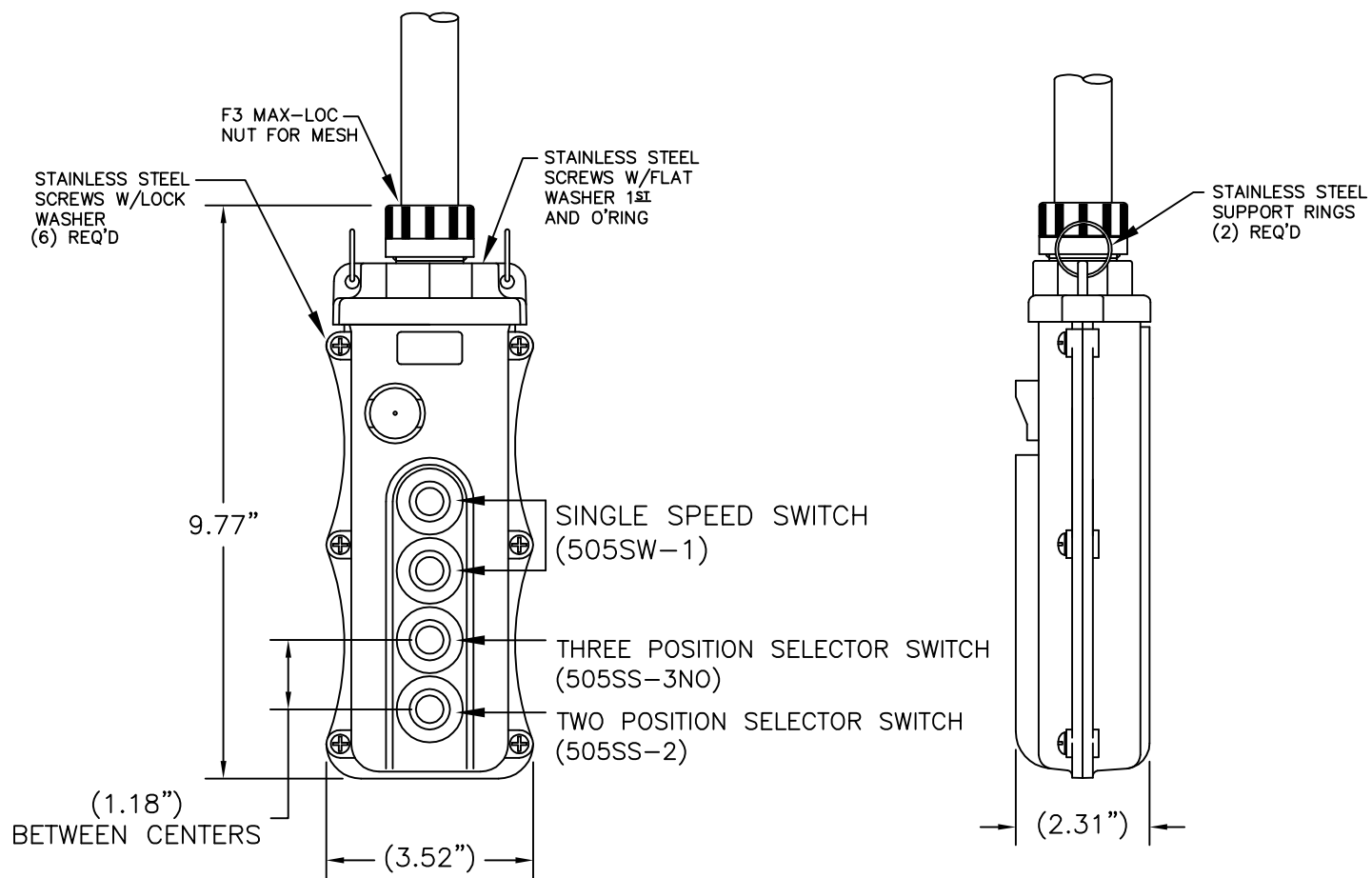

CUSTOMER DRAWING EC NO: WNA208-0100 DRWN: TVICKERS 2008/08/08 CHKD: HK 2008/09/08 APPR: SZAFAR 2008/08/13	QUALITY SYMBOLS ▽=0 ∇=0	GENERAL TOLERANCES (UNLESS SPECIFIED)		DIMENSION STYLE		SCALE	DESIGN UNITS	THIRD ANGLE PROJECTION		
			mm	INCH	----	NTS	INCH			
		4 PLACES	±---	±---	TV	DATE	TITLE			
		3 PLACES	±---	±---.005	2008/08/08	2008/08/08	4 POS PENDANT W/(2) 505SW-1			
2 PLACES	±---	±---.010	HK	DATE	505SS-3NO 505SS-2					
1 PLACE	±---	±---.020	APPROVED BY	DATE	MOLEX INCORPORATED					
ANGULAR ±1/2°		DRAFT WHERE APPLICABLE MUST REMAIN WITHIN DIMENSIONS		SZ	DATE	DOCUMENT NO.		SHEET NO.		
				MATERIAL NO.	2008/08/08	SD-130126-015		1 OF 1		
A		A		SIZE	THIS DRAWING CONTAINS INFORMATION THAT IS PROPRIETARY TO MOLEX INCORPORATED AND SHOULD NOT BE USED WITHOUT WRITTEN PERMISSION					

6

5

4

3

2

1