

DO NOT SCALE FROM THIS PRINT

DESIGNED & DIMENSIONED IN INCHES[MILLIMETERS]

PRF35-P-C-EP-402-SS

SERIES
-35: 3.5mm
GENDER
-P: PLUG
TYPE
-C: CABLE

TERMINATION
-S: SOLDER CLAMP

ORIENTATION
-S: STRAIGHT

CABLE TYPE
-402: RG-402 SEMI-RIGID

FINISH
-EP: 50µ" EXTRA HEAVY GOLD
CENTER CONTACT, PASSIVATED
OUTER CONTACT

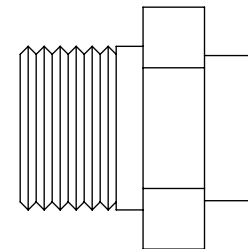
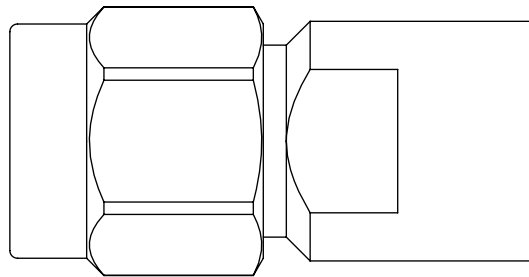
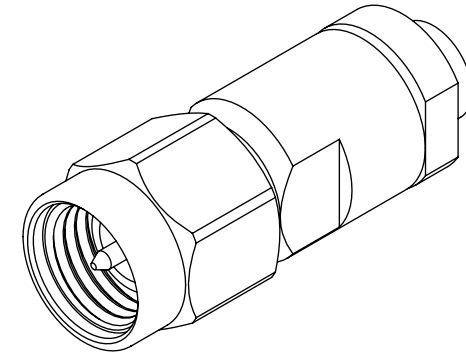
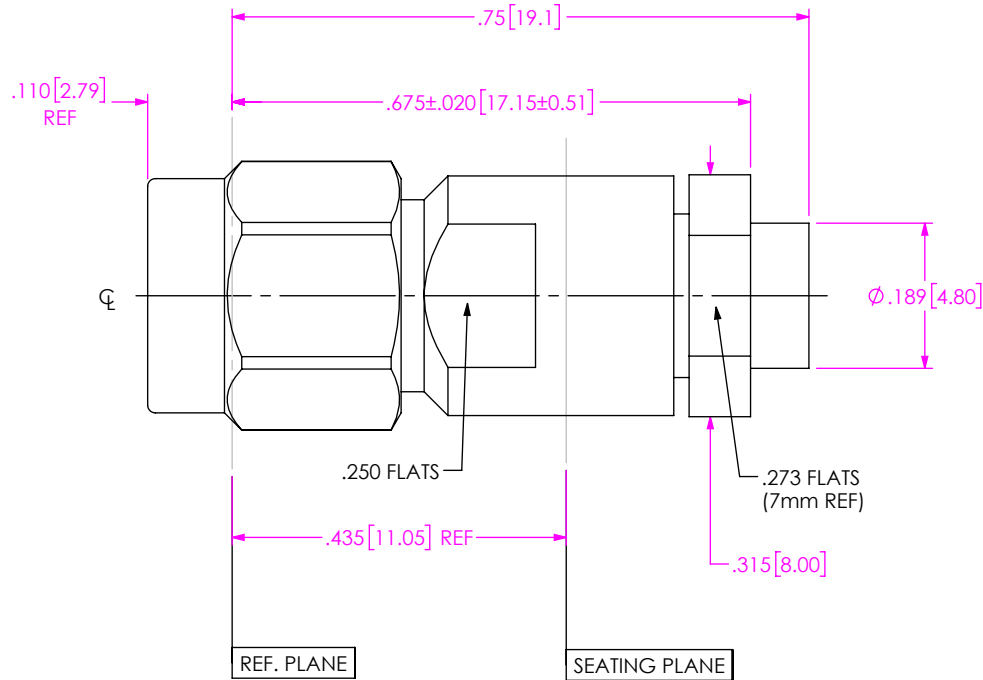

EXPLODED VIEW
NOT TO SCALE
(FOR CLARITY ONLY)

NOTES:

- MATERIAL:
BODY, BUSHING, COUPLING NUT: STAINLESS STEEL
CONTACT, LOCK RING: BERYLLIUM COPPER
CLAMP NUT: BRASS ALLOY
BEAD: PCTFE
GASKET: SILICONE RUBBER
- FINISH:
BODY, BUSHING, COUPLING NUT: PASSIVATED
CONTACT, CLAMP NUT: 50µ" MIN. GOLD OVER 50µ" MIN. NICKEL PLATE
- PCI P/N: 3774

F:\DWG\MISC\MKTG\PRF35-P-C-EP-402-SS-MKT.SLDDRW

UNLESS OTHERWISE SPECIFIED, DIMENSIONS ARE IN INCHES. TOLERANCES ARE: DECIMALS ANGLES .XX: ±.01 [0.3] 1° .XXX: ±.005 [0.13] .XXXX: ±.0005 [0.013]	* PROPRIETARY NOTE * THIS DOCUMENT CONTAINS CONFIDENTIAL AND PROPRIETARY INFORMATION AND ALL DESIGN, MANUFACTURING, REPRODUCTION, USE, PATENT RIGHTS AND SALES RIGHTS ARE EXPRESSLY RESERVED BY SAMTEC, INC. THIS DOCUMENT SHALL NOT BE DISCLOSED, IN WHOLE OR PART, TO ANY UNAUTHORIZED PERSON OR ENTITY NOR REPRODUCED, TRANSFERRED OR INCORPORATED IN ANY OTHER PROJECT IN ANY MANNER WITHOUT THE EXPRESS WRITTEN CONSENT OF SAMTEC, INC.	 520 PARK EAST BLVD, NEW ALBANY, IN 47150 PHONE: 812-944-6733 FAX: 812-948-5047 e-Mail: info@SAMTEC.com code 55322	
	DO NOT SCALE DRAWING SHEET SCALE: 4:1		DESCRIPTION: 3.5 MM PLUG SOLDER CLAMP NUT FOR RG-402 SEMI-RIGID CABLE
	DWG. NO. PRF35-P-C-EP-402-SS		BY: SAMUEL C 04/08/2019 SHEET 1 OF 2

CABLE APPLICATION VIEWS

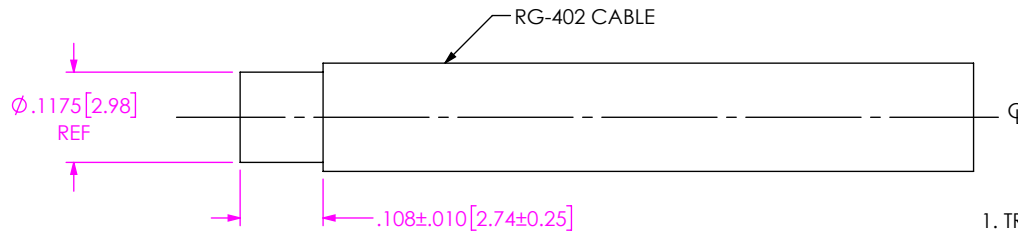

IN-PROCESS VIEW 1

1. TRIM CABLE JACKET TO EXPOSE DIELECTRIC CORE AS SHOWN.

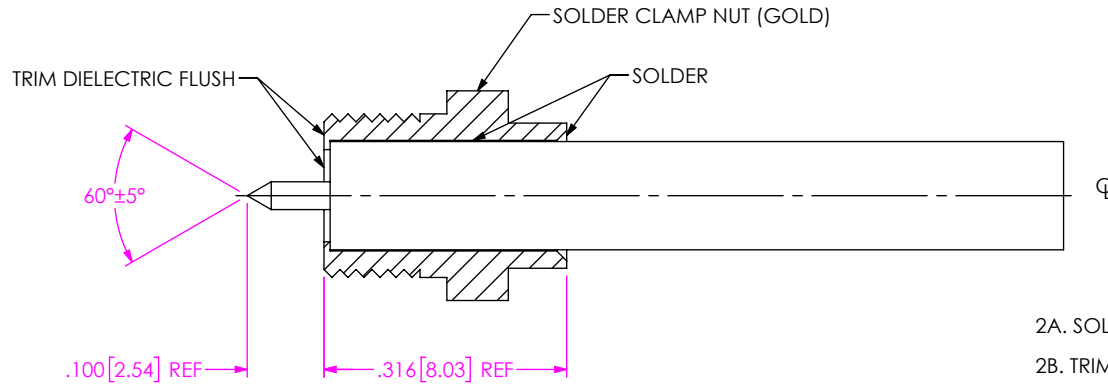

IN-PROCESS VIEW 2

- 2A. SOLDER CLAMP NUT TO CABLE AS SHOWN.
- 2B. TRIM CABLE DIELECTRIC FLUSH WITH FACE OF CLAMP NUT AS SHOWN.
- 2C. POINT CABLE CENTER CONDUCTOR AS SHOWN.

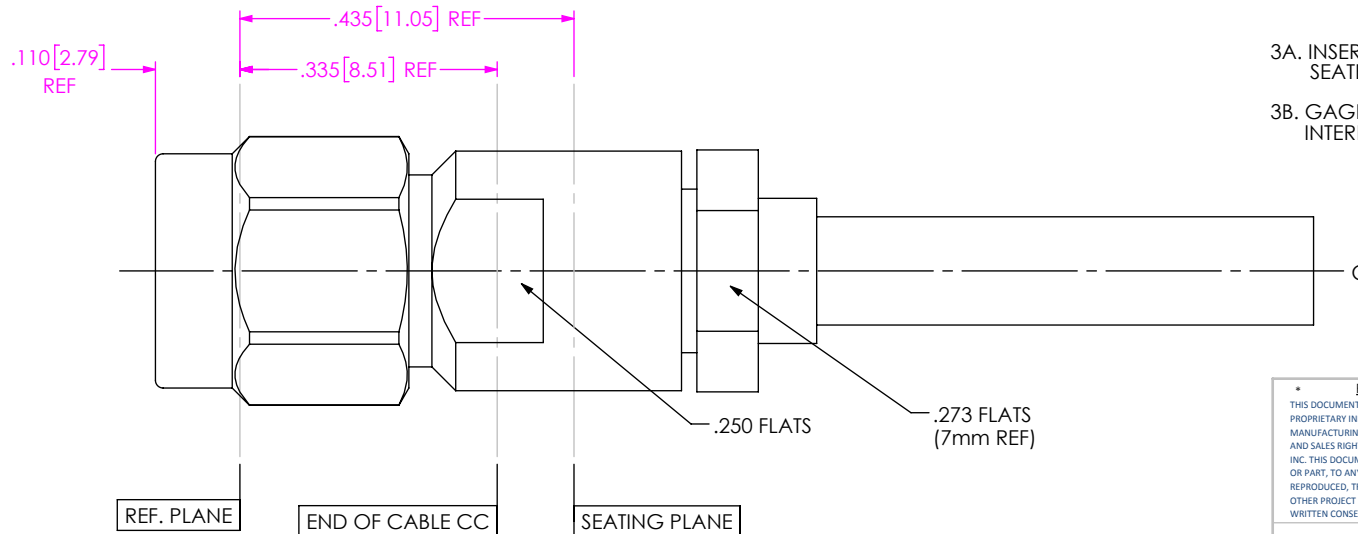

IN-PROCESS VIEW 3

- 3A. INSERT CABLE SUB-ASSEMBLY INTO CONNECTOR UNTIL SEATED AND TORQUE TO 25-30 IN-LBS.
- 3B. GAGE CONTACT RECESSON FROM CONNECTOR INTERFACE. (.000/.003 SUB-FLUSH).

DISTANCE FROM END OF CABLE CENTER CONDUCTOR TO REF PLANE IS .335 REF

PROPRIETARY NOTE
 THIS DOCUMENT CONTAINS CONFIDENTIAL AND PROPRIETARY INFORMATION AND ALL DESIGN, MANUFACTURING, REPRODUCTION, USE, PATENT RIGHTS AND SALES RIGHTS ARE EXPRESSLY RESERVED BY SAMTEC, INC. THIS DOCUMENT SHALL NOT BE DISCLOSED, IN WHOLE OR PART, TO ANY UNAUTHORIZED PERSON OR ENTITY NOR REPRODUCED, TRANSFERRED OR INCORPORATED IN ANY OTHER PROJECT IN ANY MANNER WITHOUT THE EXPRESS WRITTEN CONSENT OF SAMTEC, INC.



520 PARK EAST BLVD, NEW ALBANY, IN 47150
 PHONE: 812-944-6733 FAX: 812-948-5047
 e-Mail: info@SAMTEC.com code 55322

DO NOT SCALE DRAWING

SHEET SCALE: 4:1

DESCRIPTION: 3.5 MM PLUG SOLDER CLAMP NUT FOR RG-402 SEMI-RIGID CABLE

DWG. NO. PRF35-P-C-EP-402-SS

BY: SAMUEL C 04/08/2019 SHEET 2 OF 2