

May.1.2023 Copyright 2023 HIROSE ELECTRIC CO., LTD. All Rights Reserved.
In case of consideration for using Automotive equipment / device which demand high reliability, kindly contact our sales window correspondents.

[How to insert plug] ② (FREE)

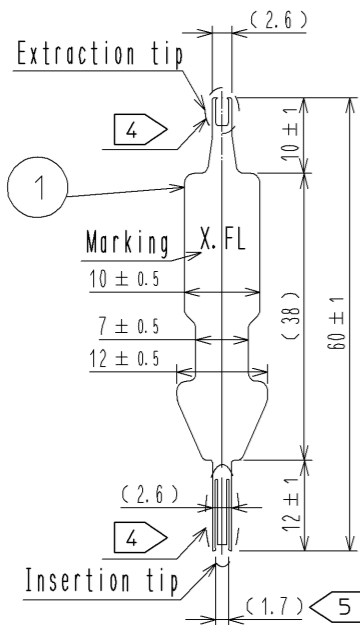

[How to extract plug]

Extraction method1 ③ (FREE)

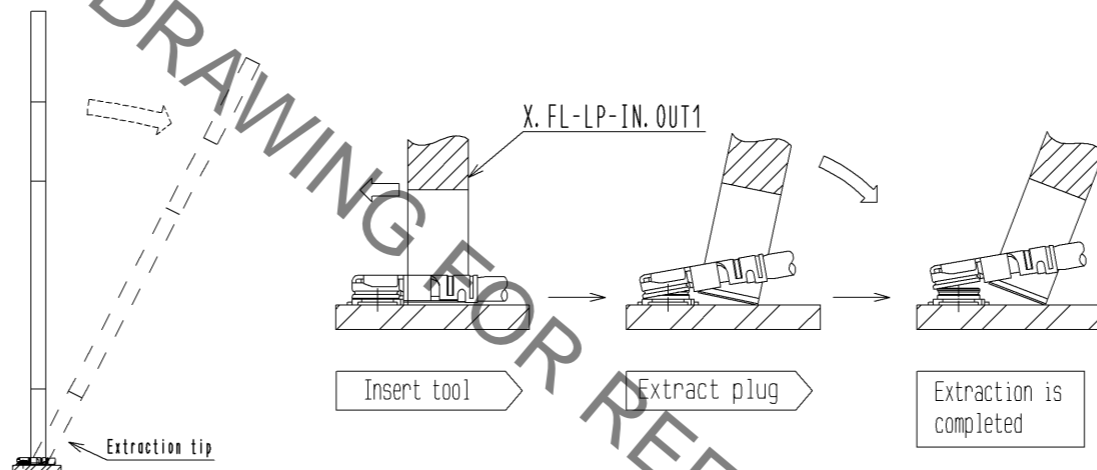

Extraction method2 ③ (FREE)

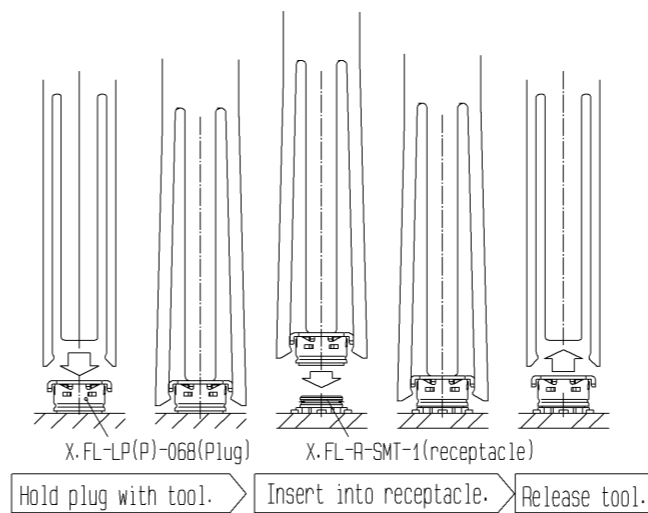
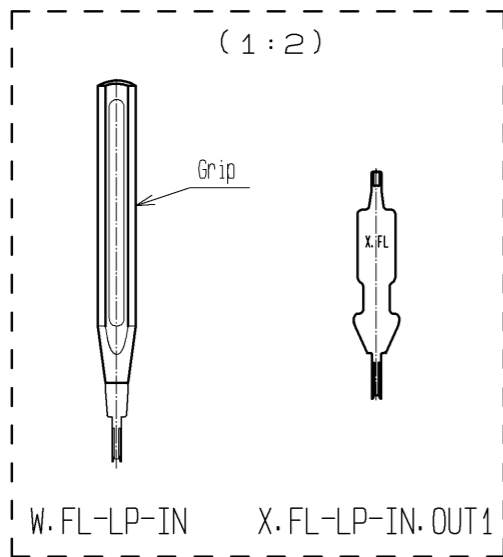
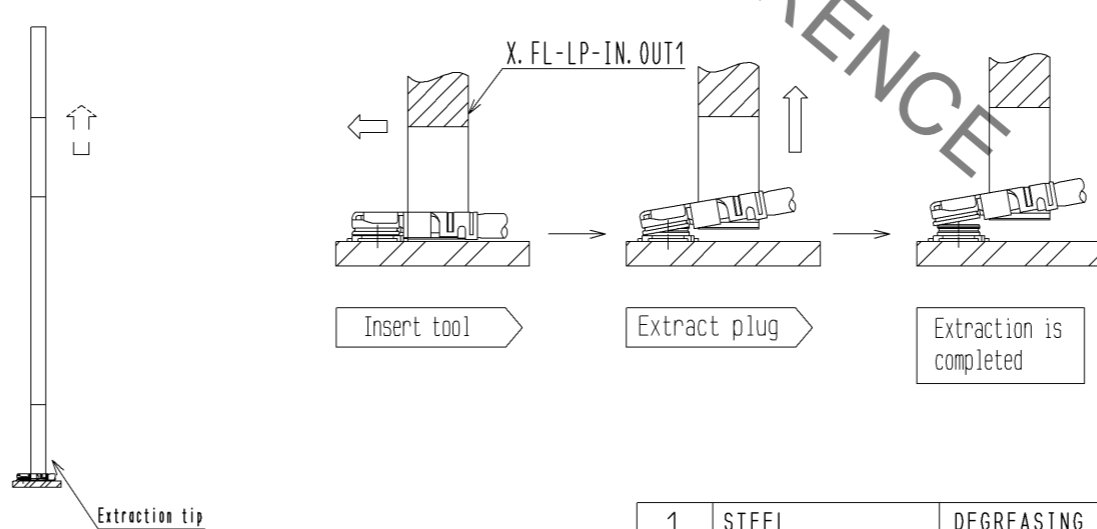

Notes 1. This tool is to help insertion / extraction operation of X.FL-LP(P)-068 Plug to / from X.FL-R-SMT-1 Receptacle. Refer to the figure on the right for the operation instructions.

- ② At the time of plug insertion, align the mating axes of the plug and the receptacle. Confirm that the plug is positioned to be guided (The both axes are aligned and the plug is positioned stably.). Then insert the plug as straight as possible. Avoid an angled insertion.
- ③ Extract the plug as shown in the figure(Extraction method1 or method2). Take a caution not to pull at the cable. Pulling at the cable can damage the connectors.
- ④ The tool tips are structurally vulnerable to deformation. The tips are likely to be deformed when the tool is dropped. Handle carefully
- ⑤ Modify the tool opening dimensions of the insertion tip for the operator's comfort, if necessary. Check that the tool does not scratch X.FL-LP(P)-068 Plug.
- 6. When the connector insertion is difficult due to limited operation space at the mounted area, a special insertion tool (W.FL-LP-IN. CL331-0323-2) may become helpful. The size comparison is shown in the figure below.

RoHS COMPLIANT

1	STEEL	DEGREASING				
NO.	MATERIAL	FINISH . REMARKS	NO.	MATERIAL	FINISH . REMARKS	
UNITS mm		SCALE 1 : 1	COUNT 	DESCRIPTION OF REVISIONS		DESIGNED
APPROVED : MH. YAMANE			14. 03. 20	DRAWING NO.		EDC3-352093-00
CHECKED : NK. NINOMIYA			14. 03. 19	PART NO.		X.FL-LP-IN. OUT1
DESIGNED : RO. YOKOYAMA			14. 03. 18	CODE NO.		CL331-0715-2-00
DRAWN : RO. YOKOYAMA			14. 03. 18			