

SJ121712
 (DRAWING NO.)

版数 VER.	年月日 DATE	CN NO.	変更内容 DESCRIPTION	製図 DR.	担当 CHK.	査閲 APPD.	承認 APPD.
------------	-------------	--------	---------------------	-----------	------------	-------------	-------------

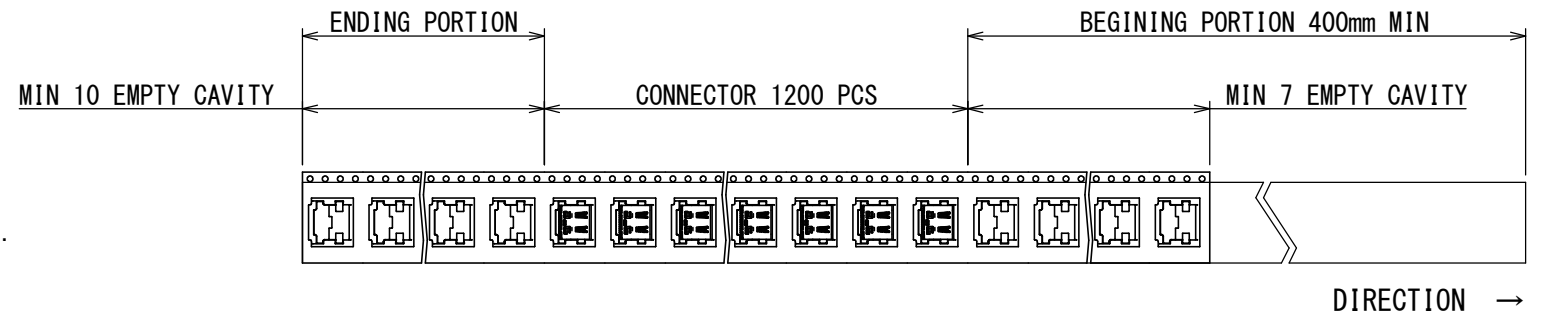
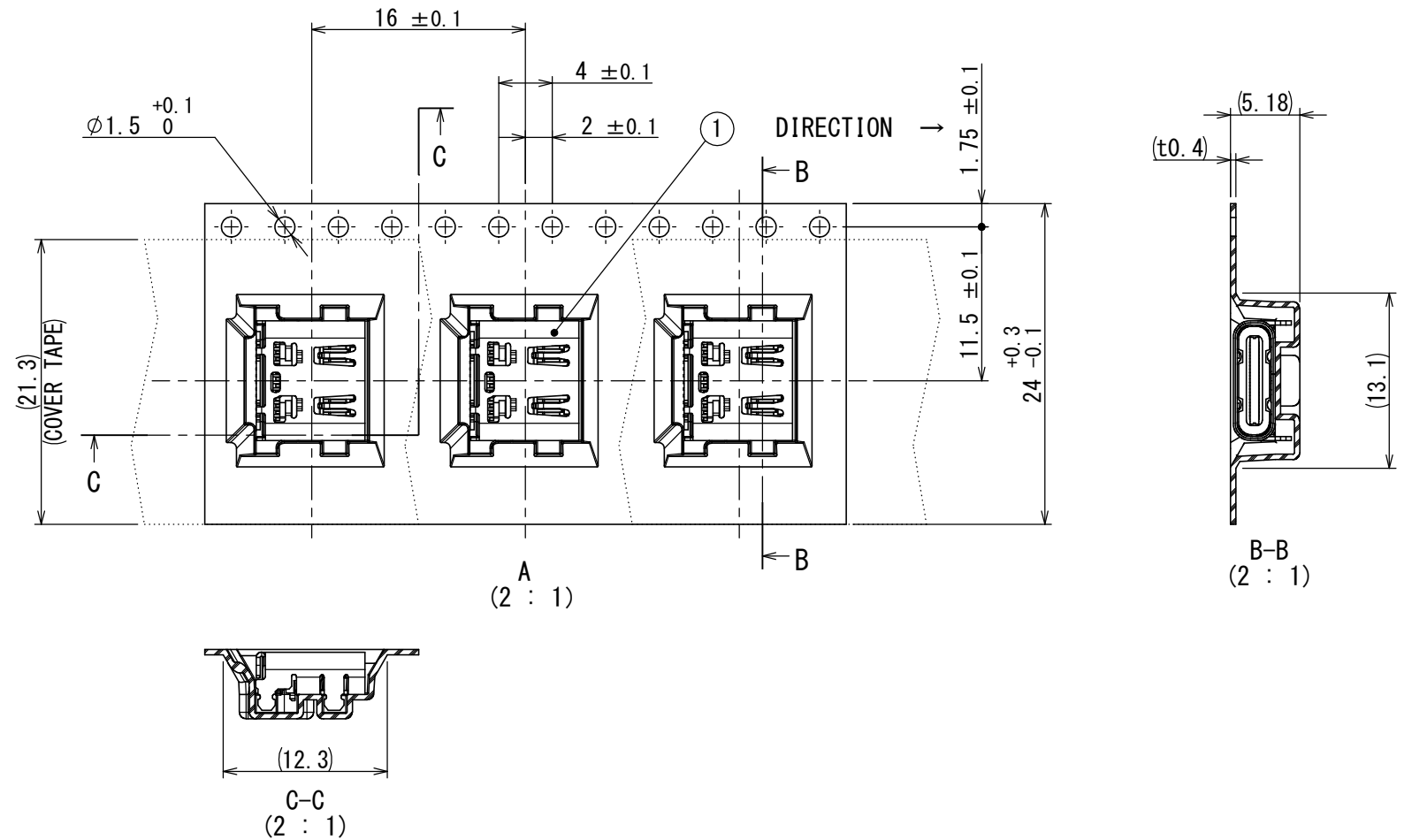
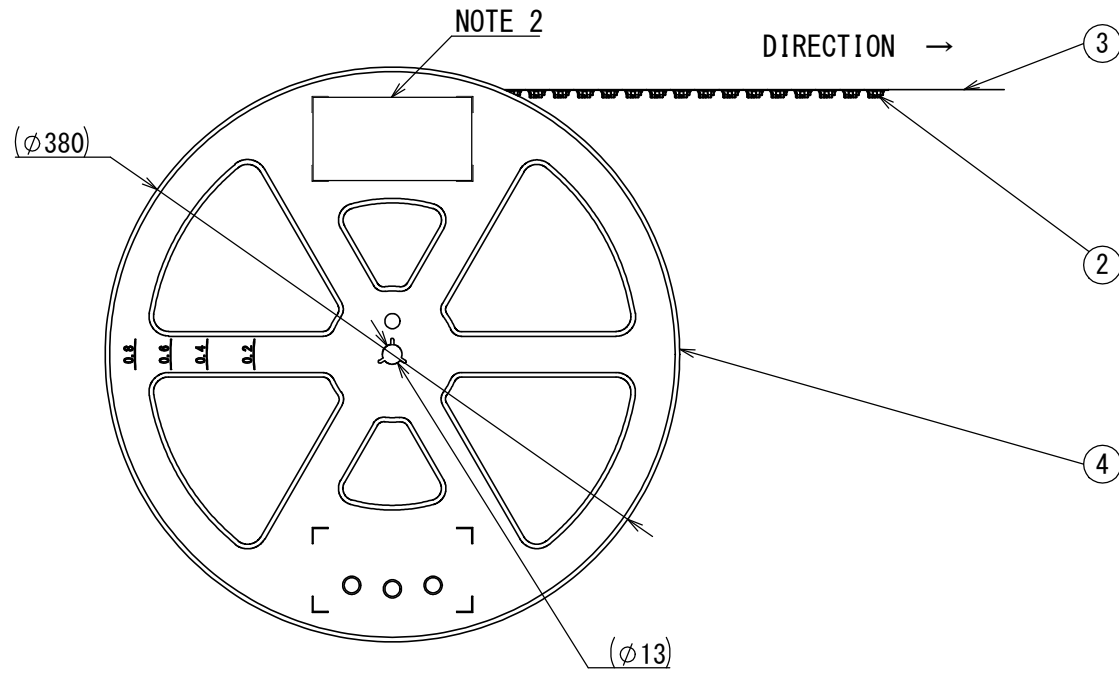
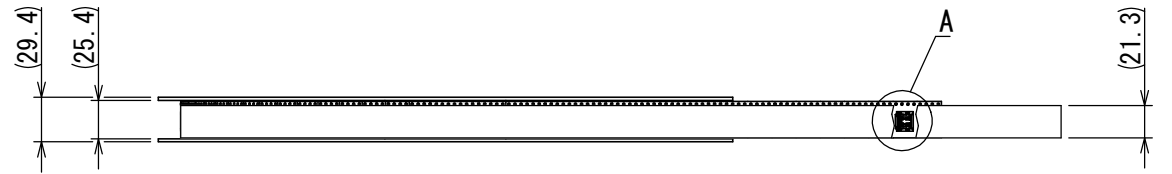

NOTE 1. SUFFIX "R1200" OF PART NUMBER "DX07S024JA2R1200" INDICATES 1200PCS IN A REEL.
 NOTE 2. THE LABEL IN WHICH DESCRIPTION, QTY, LOT NO, EMBOSS CODE AS INDICATED.
 NOTE 3. REFER TO THE DRAWING "SJ121711 (DX07S024JA2)" FOR THE CONNECTOR DIMENSIONS.
 NOTE 4. REEL FORM MAY DIFFER FROM THE DRAWING.

現品ラベル/ARTICLE LABEL

XXXXXXXXXX XXXX XXXX XXXX
 Count: 001
 JAE001

品名 (DESCRIPTION) DX07S024JA2R1200
 図番 (PART No.) SJ121712
 数量 (Q'ty) 1200

ITEM NO
 Lot No.
 E Code: TB2416

2019/09/19
 MADE IN JAPAN
 QCF-C-0628 (07.12) / JAPS-9006-2

Japan Aviation Electronics Industry, Ltd.

24: TAPE WIDTH 16: FEED PITCH

符号 NO.	名称 DESCRIPTION	個数 QTY.	材料 MATERIAL	仕上 FINISH	備考 REMARKS
4	REEL	1	PS	—	—
3	COVER TAPE	1	PET	—	—
2	CARRIER TAPE	1	PS	—	—
1	DX07S024JA2	1200	—	—	SJ121711

仕様書 (SPECIFICATION) JACS-30353-19 JAHL-30353-5	第1版 (ORIGINAL DATE) 19/SEP/2019	尺度 (SCALE) 1:5	シリーズ (SERIES) DX07	日本航空電子工業株式会社 JAPAN AVIATION ELECTRONICS INDUSTRY, LTD.
一般公差 (GENERAL TOLERANCE) 寸法 (DIMENSION) ±0.8 × ±0.4 ×× ±0.1 ××× ±	角度 (ANGLES) ×° ± ×°×' ± 単位 (UNIT) : mm	製図 DR. —	名称 (TITLE) DX07S024JA2R1200	図面番号 (DRAWING NO.) SJ121712
	担当 CHK. Y. SHIMOMAKI	質量 (MASS)	承認 APPD. Y. YOKOYAMA	版数 (VER.) 1
	査閲 APPD. Y. SAITOU			

DCF-C-212H(12.08)



WISDOM承認 2019/09/20

SIZE A3