

LOC	DIST	REVISIONS			
GP	00	REV	DATE	BY	APPD
		A	20AUG2009	RG	RL

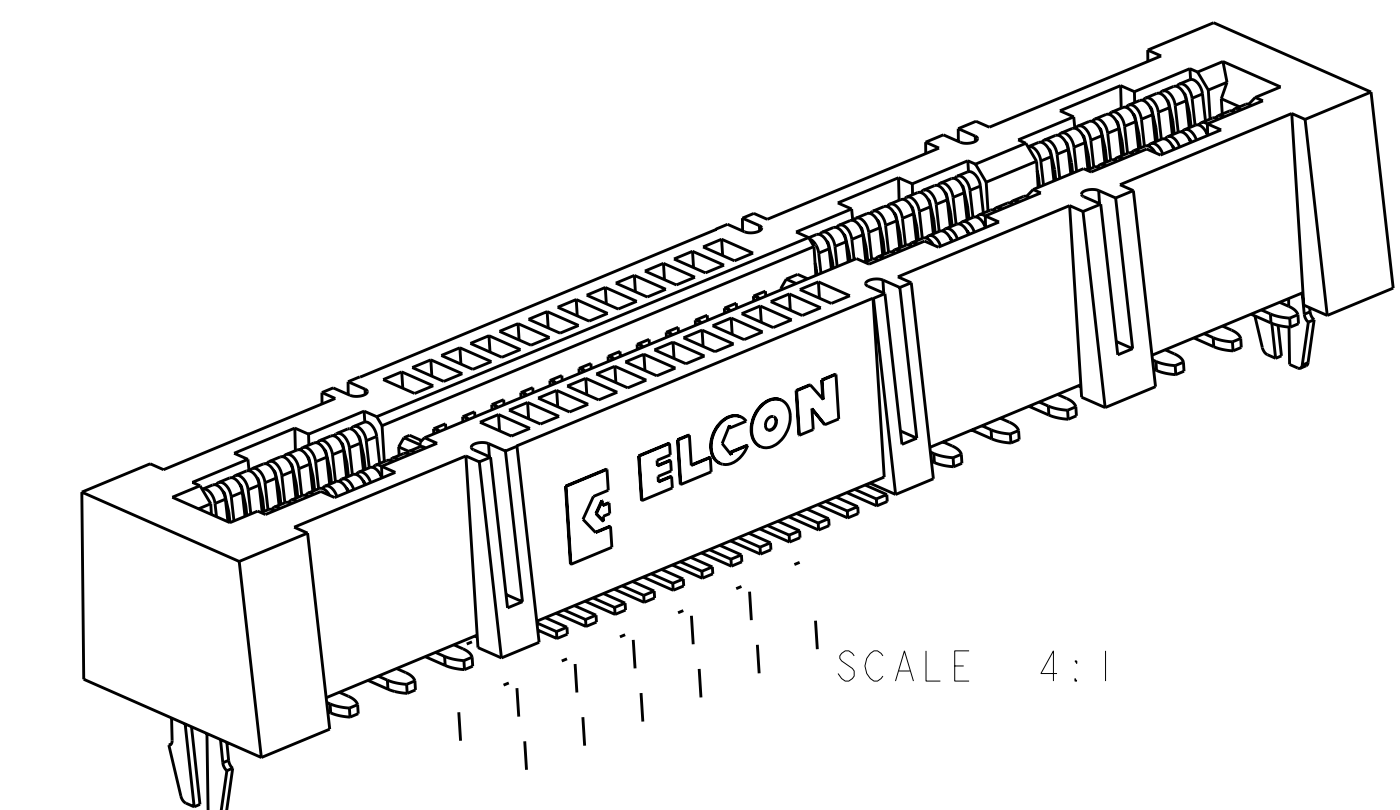
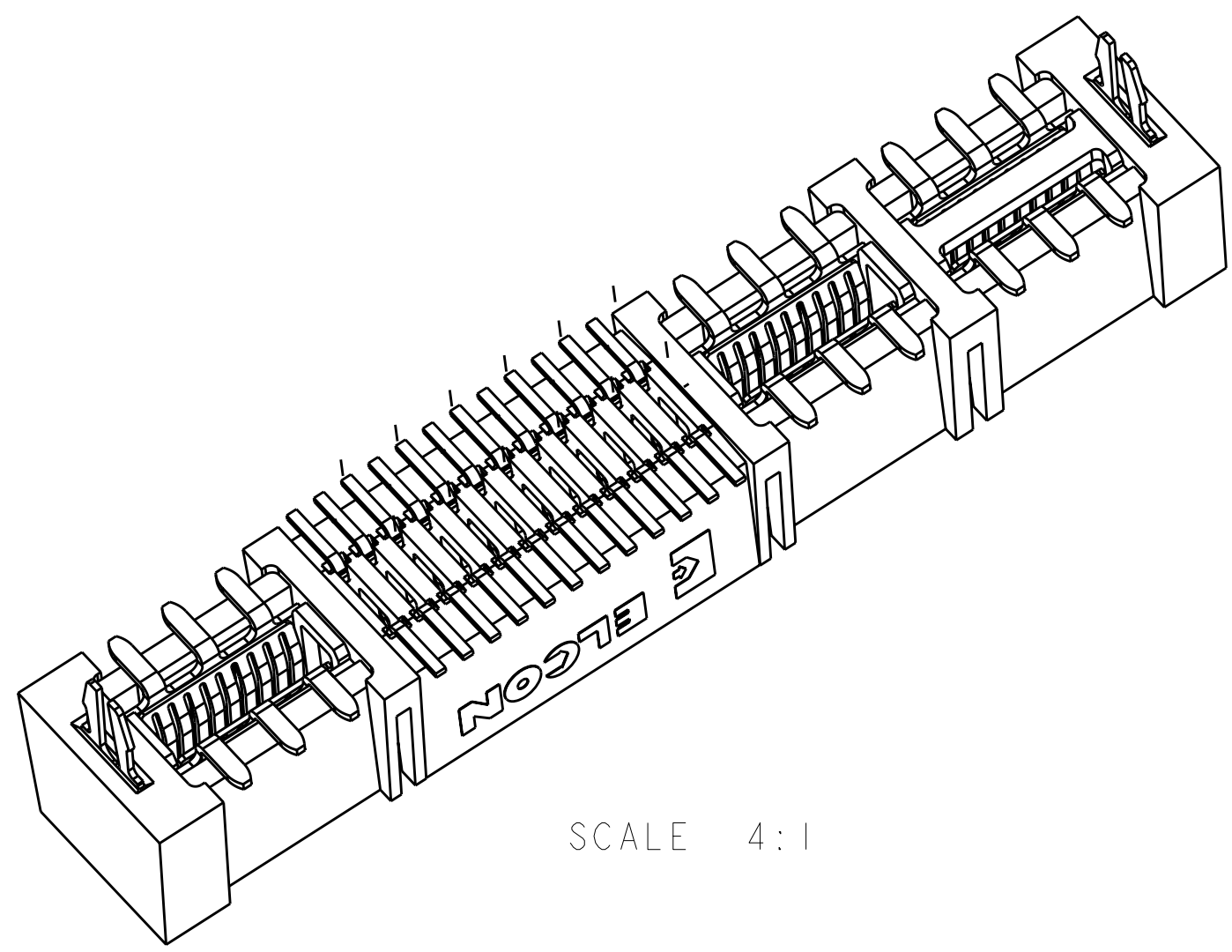
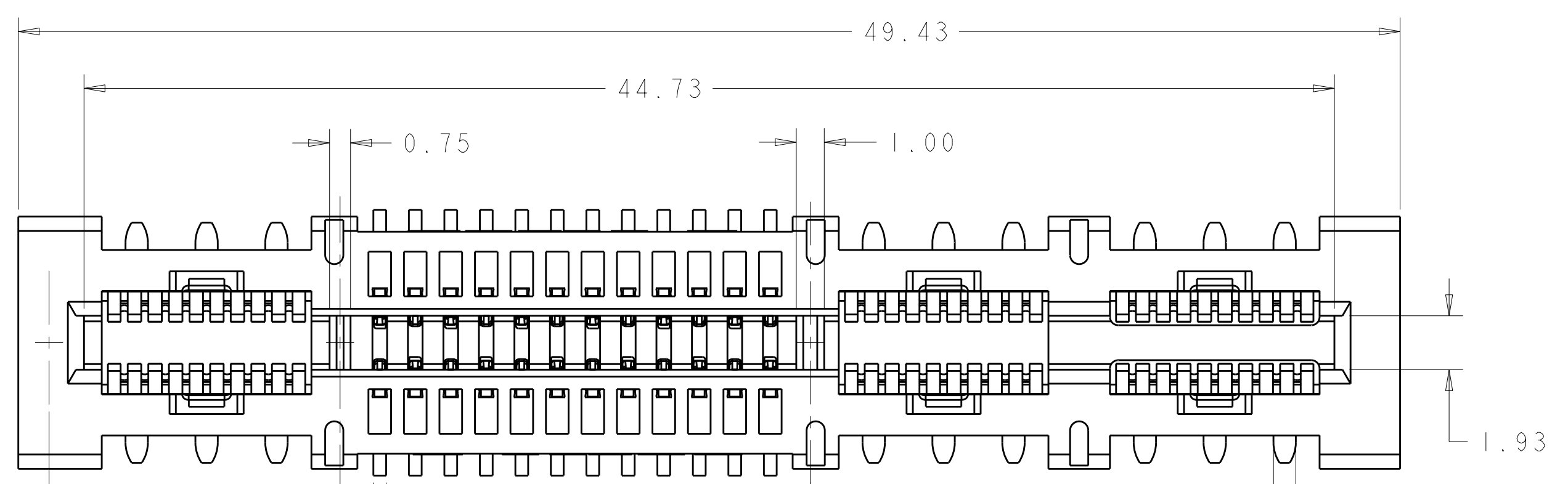

1. PART NUMBER CHANGES AND OR DESIGN CHANGES AFFECTING ITEM INTERCHANGEABILITY REQUIRE PRIOR TYCO ELECTRONICS APPROVAL AND AUTHORIZATION BY REVISION TO THIS DRAWING.

2. MATERIAL:
 INSULATOR - THERMOPLASTIC, GLASS REINFORCED UL94V-0
 COLOR: BLACK, FLAMMABILITY RATED
 CONTACTS - COPPER ALLOY

3. FINISH:
 POWER CONTACT - SELECTIVE GOLD PLATE 0.76µm MIN THK. OVER NICKEL 1.27µm MIN THK.
 SMT TAILS - TIN PLATE 3.05µm MIN. THK. OVER NICKEL 1.27µm MIN. THK.

SIGNAL CONTACT - SLECTIVE GOLD PLATE 0.76µm MIN THK. OVER NICKEL 1.27µm MIN THK.
 SMT TAILS - MATTE TIN PLATE 3.81µm MIN THK. OVER NICKEL 1.27µm MIN THK.

4. A REFERENCE DIMENSION (X.XX) IS WITHOUT TOLERANCE AND USED FOR INFORMATION PURPOSE ONLY.

5. ITEMS PROVIDED TO THIS SPECIFICATION TO BE PERMANENTLY IDENTIFIED PER THE FOLLOWING IDENTIFIER:

TYCO ELECTRONICS P/N YEAR 1 WEEK
 XXXXXXX-X DATE CODE (e.g. 0525) XXXX

6. DATUMS AND BASIC DIMENSIONS ESTABLISHED BY CUSTOMER.

7. MAXIMUM BURR OF 0.013 ON CARD TAB AREA.

8. CONNECTOR ACCEPTS 1.57±0.13 THK. PC BOARD.

9. KEEP OUT AREA FOR COMPONENTS ONLY.

10. RECOMMENDED GOLD FINGER LENGTH FOR RELIABLE CONTACT.

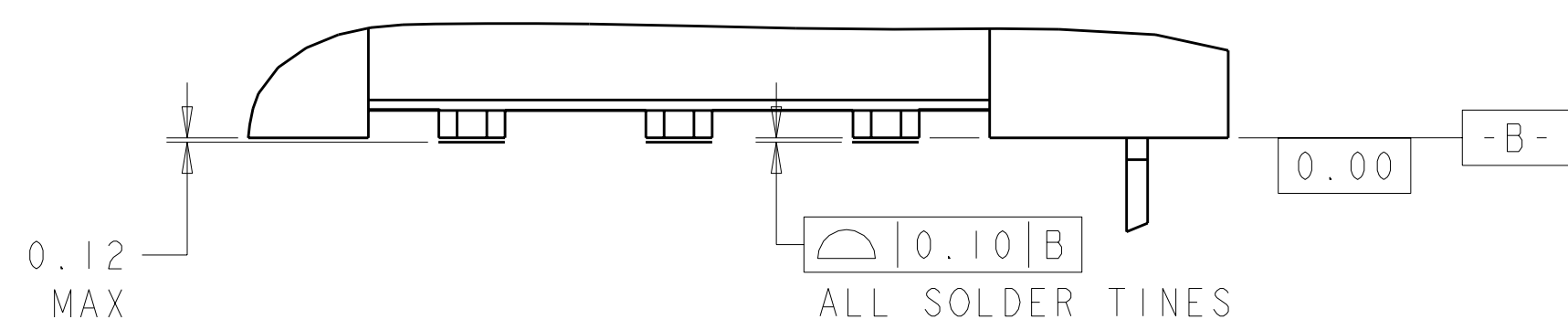
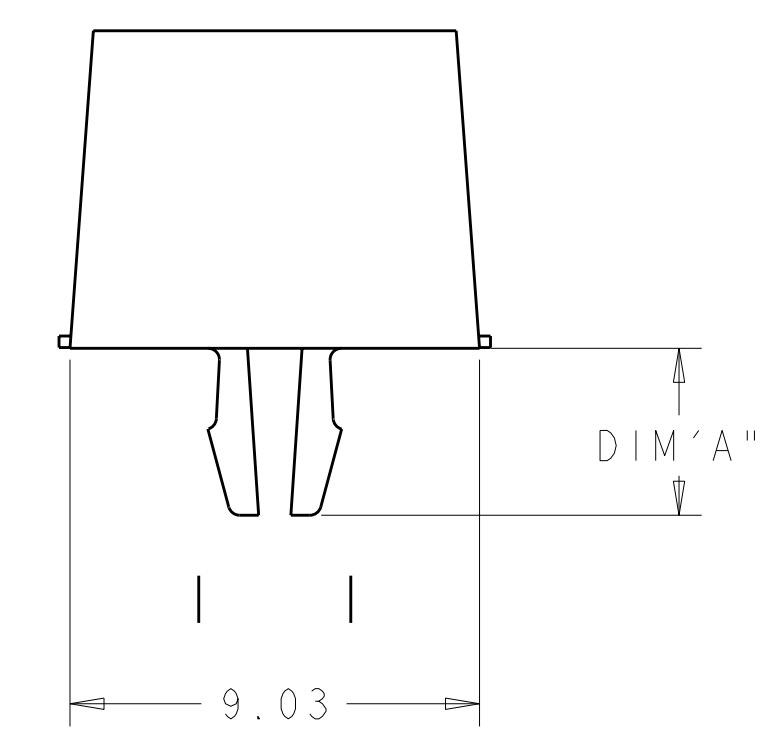
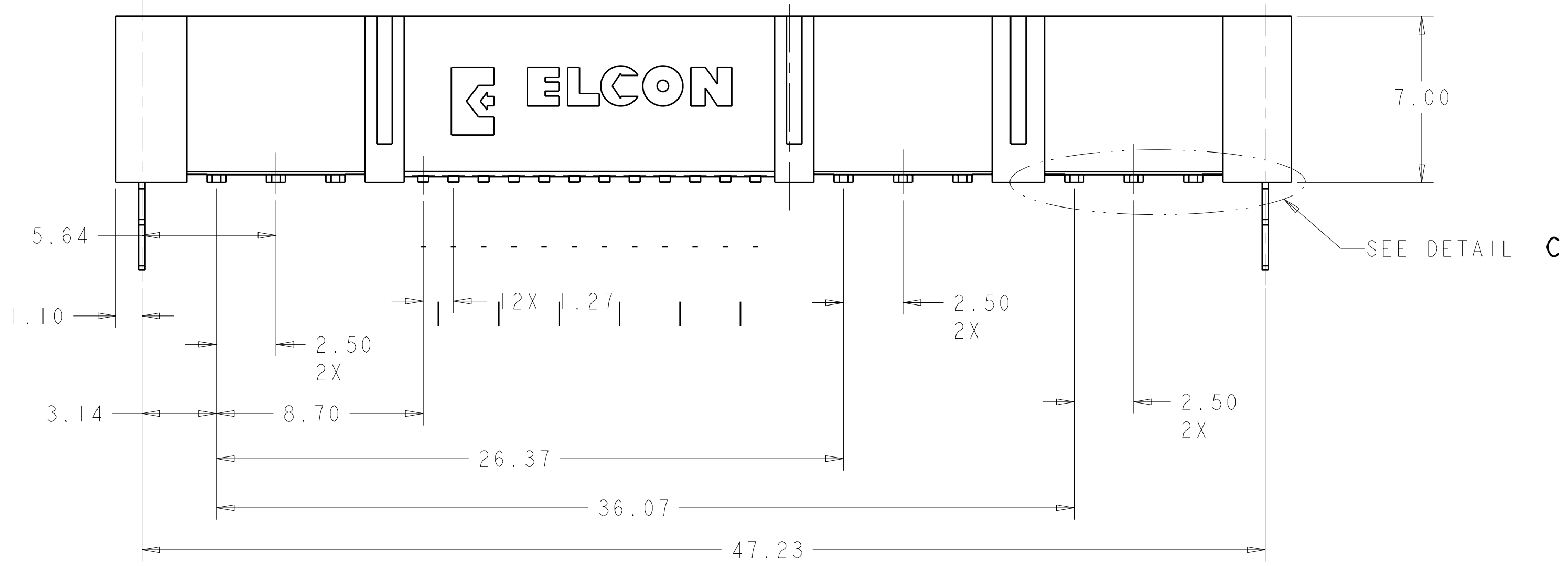

DETAIL C
 SCALE 12:1

	5.24	2.92 - 3.55	1926819-8
GF30	4.61	2.29 - 2.92	1926819-7
	4.19	1.57 - 2.29	1926819-6
	3.68	≤ 1.57	1926819-5
GF45	5.24	2.92 - 3.55	1926819-4
	4.61	2.29 - 2.92	1926819-3
	4.19	1.57 - 2.29	1926819-2
	3.68	≤ 1.57	1926819-1
MATERIAL	DIM "A"	BOARD THICKNESS RANGE	PART NO.

DIMENSIONS: mm TOLERANCES UNLESS OTHERWISE SPECIFIED: 0 PLC ±.25 1 PLC ±.25 2 PLC ±.08 3 PLC ±.08 4 PLC ±.08 ANGLES ±.3		DWN: R. GRZYBOWSKI 16APR2008 CHK: P. DAMATO 16APR2008 APVD: S. FLICKINGER 16APR2008		Tyco Electronics Harrisburg, PA 17105-3608	
MATERIAL:		FINISH:		NAME: HOUSING, SOCKET, 3 POWER, 24 SIGNAL NO LATCH, MINI CROWN EDGE PRODUCT SPEC: - APPLICATION SPEC: - WEIGHT: - CUSTOMER DRAWING: -	
SIZE: A100779C=1926819 SCALE: 8:1		SHEET: 1 OF 2 REV: A		RESTRICTED TO: -	

LOC	DIST	REV	DATE	BY	APPD
GP	00				

REVISIONS			
NO.	DATE	DESCRIPTION	BY
1		SEE SHEET 1	

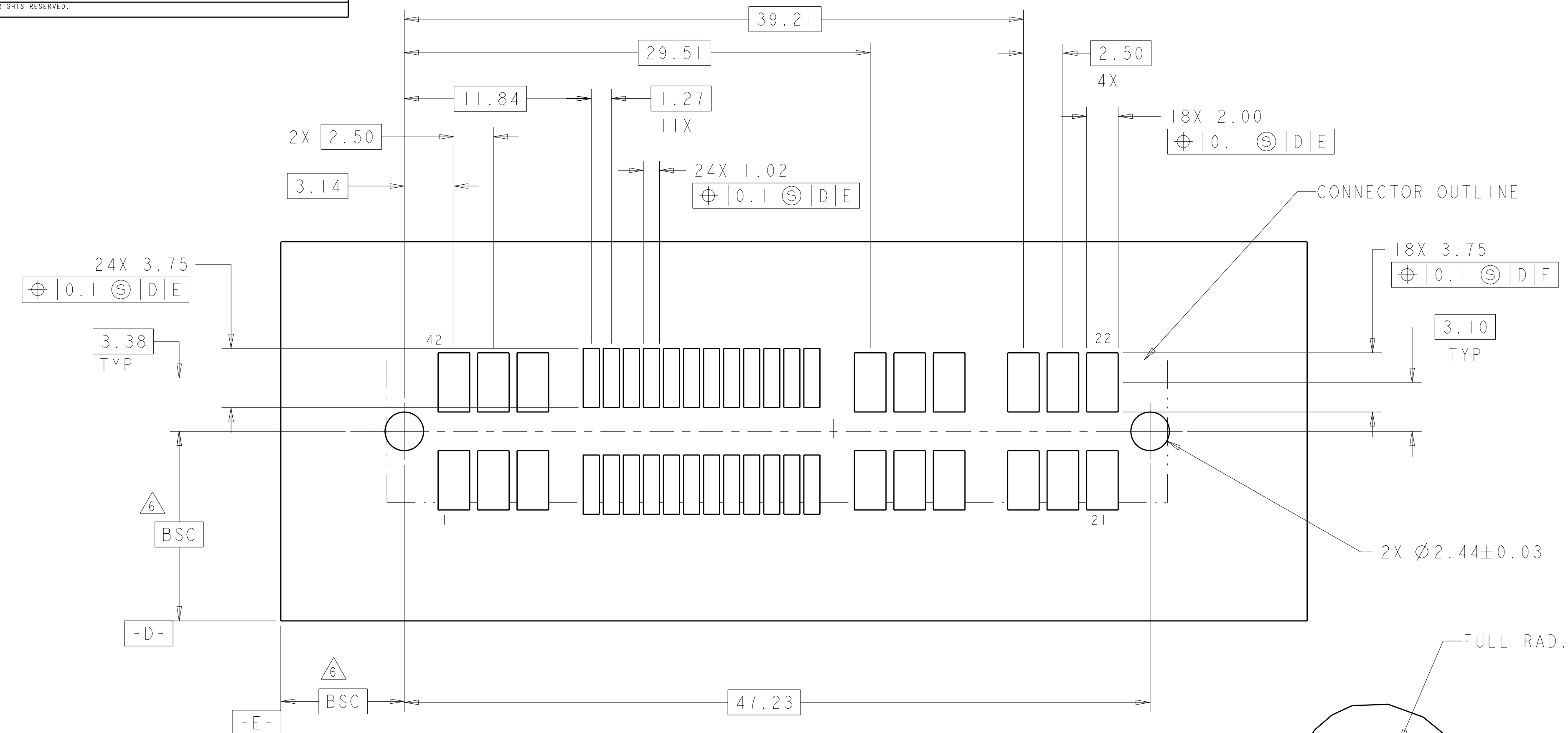

RECOMMENDED SOLDER LAND LAYOUT
 AS VIEWED FROM CONNECTOR SIDE

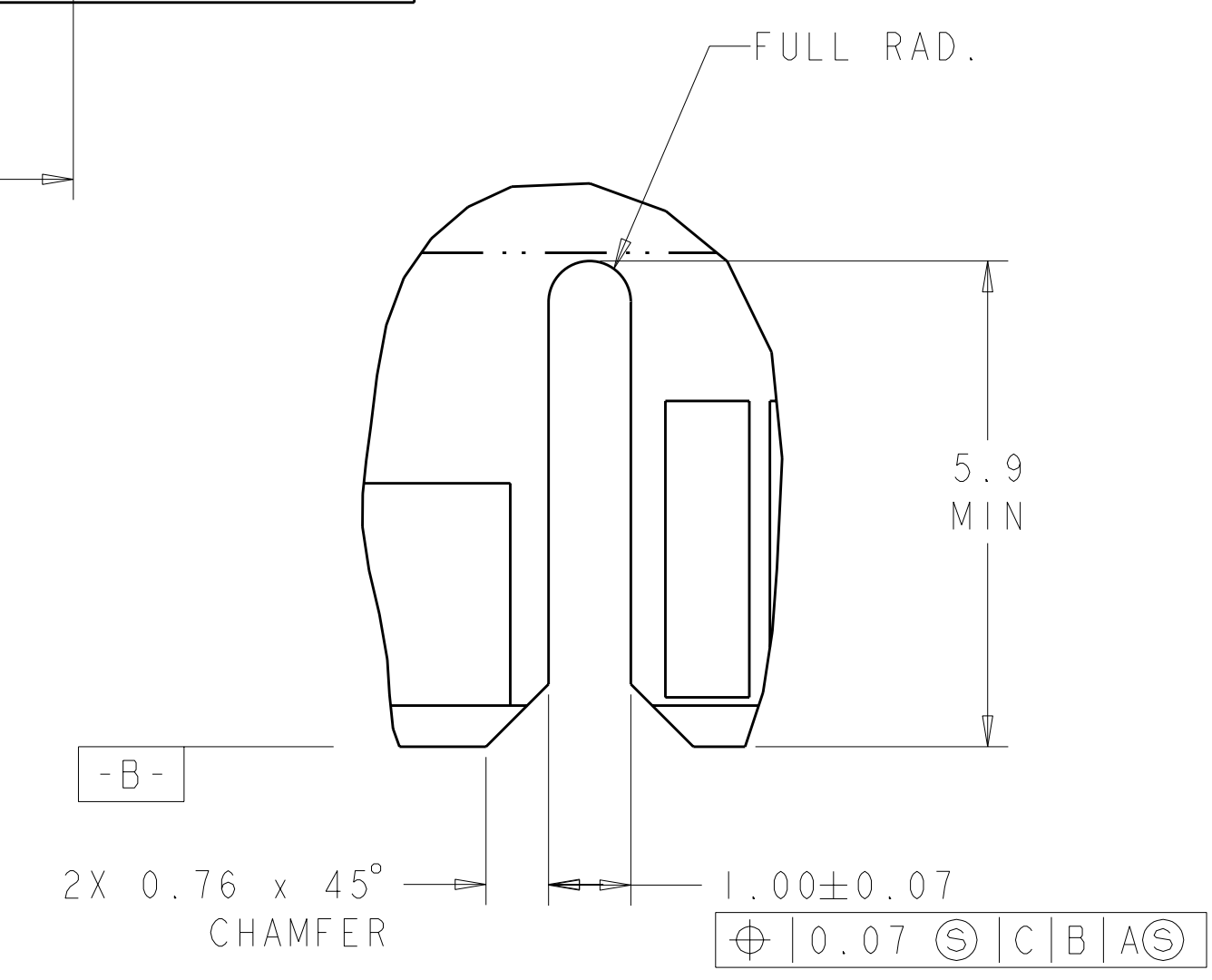

DETAIL S
 SCALE 12:1

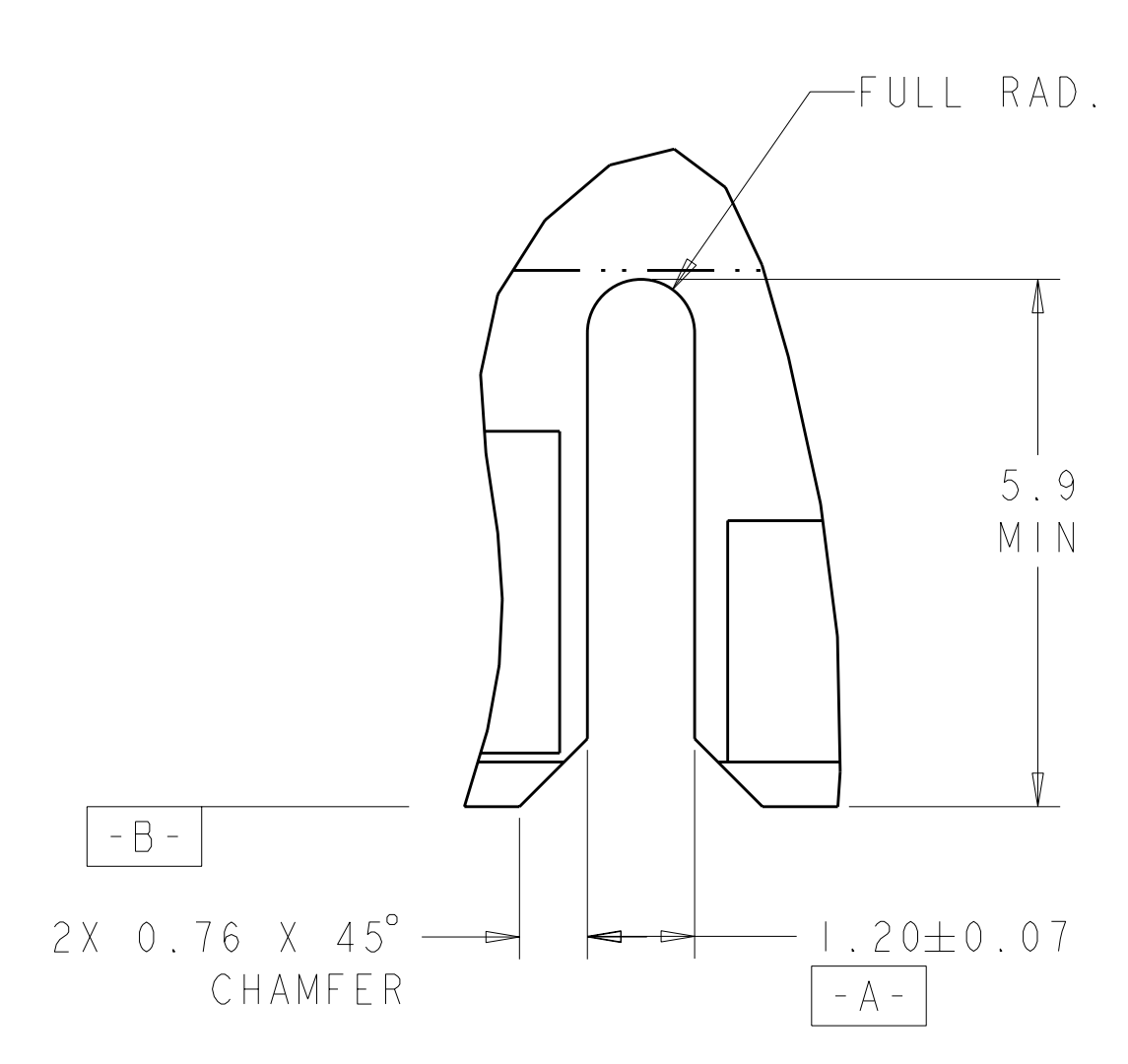

DETAIL W
 SCALE 12:1

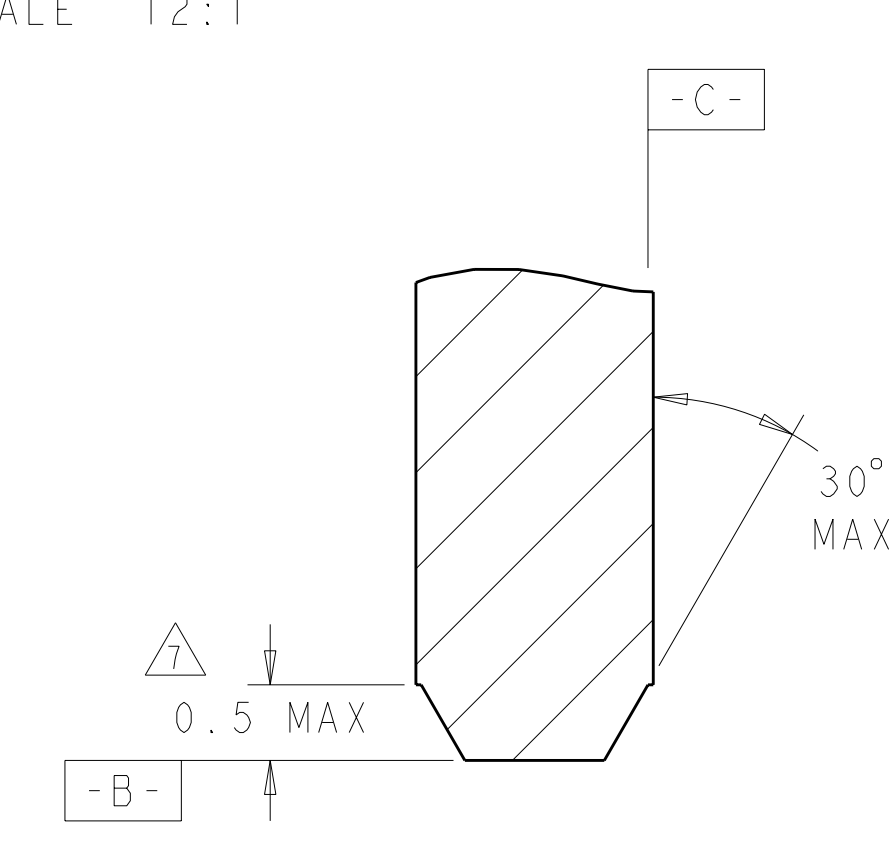

SECTION V-V
 SCALE 20:1

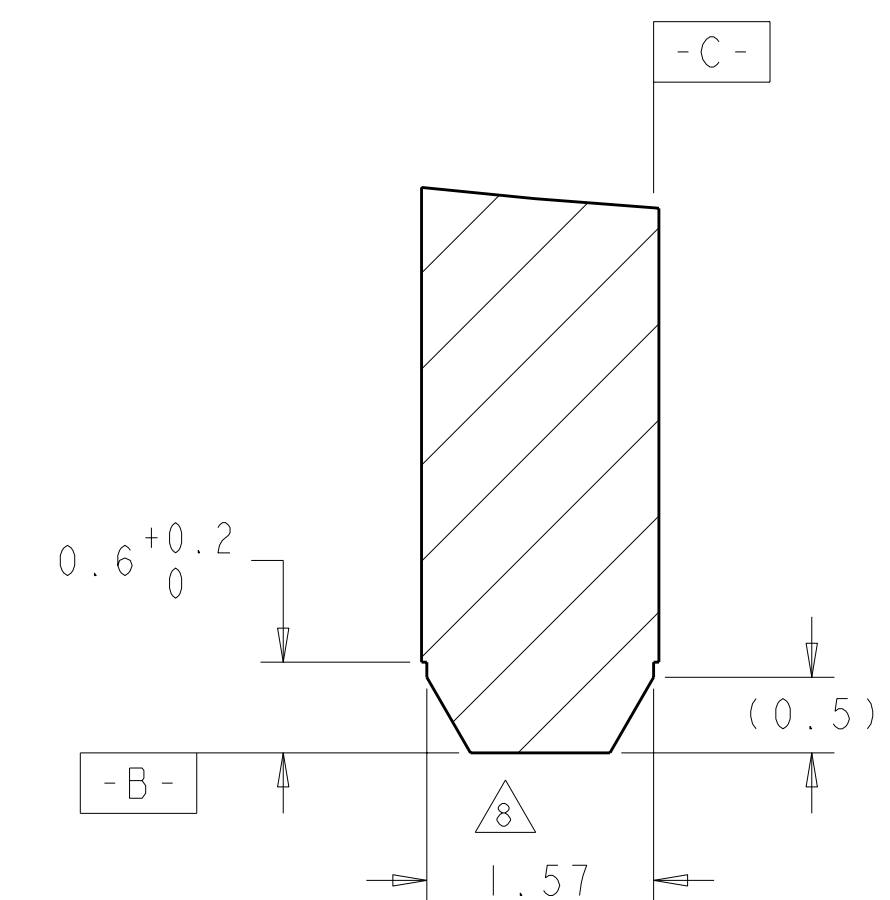

SECTION U-U
 SCALE 20:1

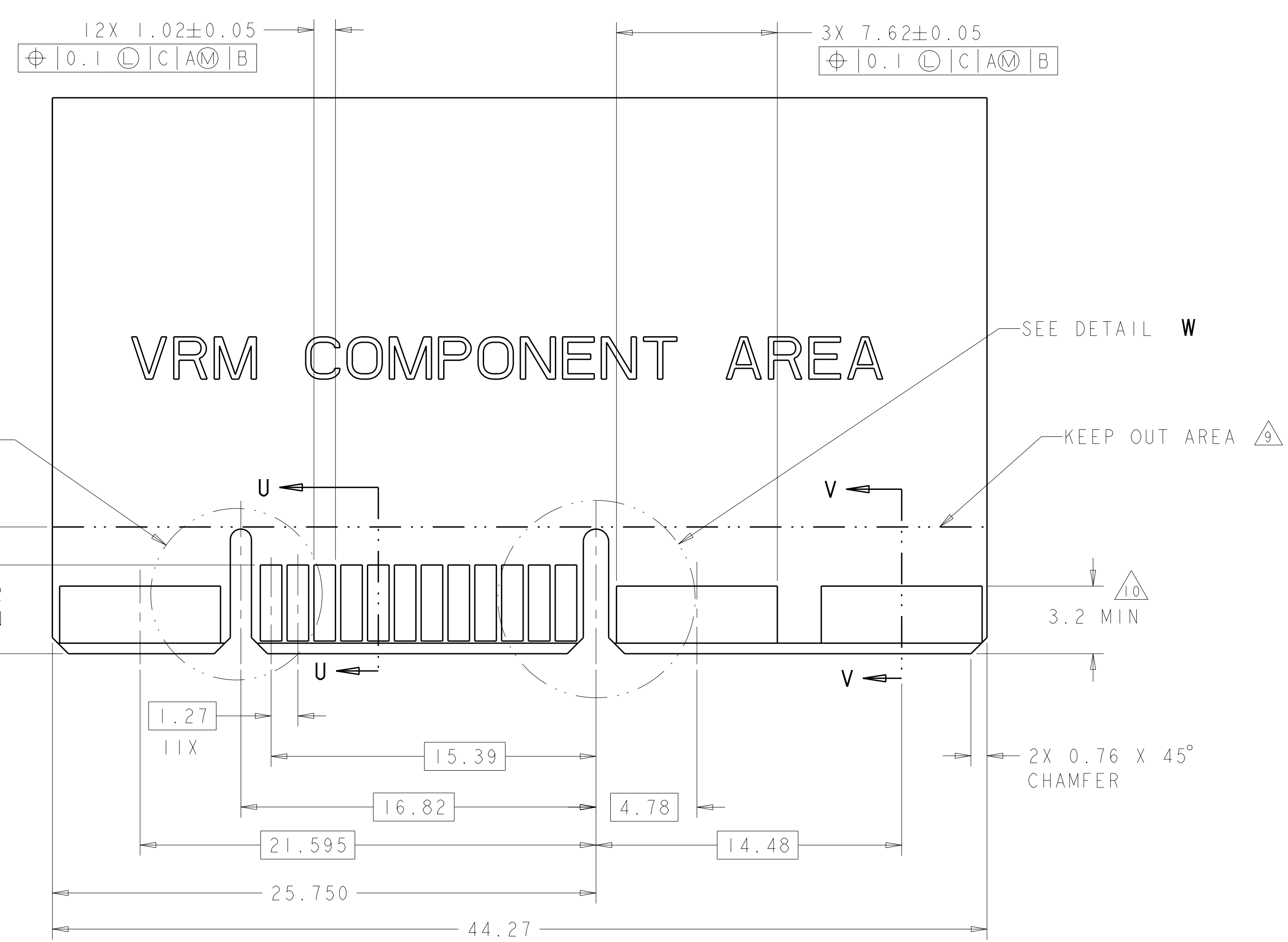

RECOMMENDED MATING BOARD
 SCALE 6:1

VRM COMPONENT AREA

DESIGN APPROVED THIS PRINT IS
PRELIMINARY
 TO FIRST PIECE APPROVAL
 CONTACT PRODUCT ENGINEERING
 BEFORE USING THIS PRINT

DIMENSIONS:		TOLERANCES UNLESS OTHERWISE SPECIFIED:		MATERIAL:		FINISH:		WEIGHT:		CUSTOMER DRAWING:	
mm		9 PLC	±.25								
		1 PLC	±.08								
		2 PLC	±.08								
		3 PLC	±.08								
		4 PLC	±.08								
		5 PLC	±.08								
		6 PLC	±.08								
		7 PLC	±.08								
		8 PLC	±.08								
		9 PLC	±.08								
		10 PLC	±.08								
		11 PLC	±.08								
		12 PLC	±.08								
		13 PLC	±.08								
		14 PLC	±.08								
		15 PLC	±.08								
		16 PLC	±.08								
		17 PLC	±.08								
		18 PLC	±.08								
		19 PLC	±.08								
		20 PLC	±.08								
		21 PLC	±.08								
		22 PLC	±.08								
		23 PLC	±.08								
		24 PLC	±.08								