

REVISIONS				
P	LTN	DESCRIPTION	DATE	APVD
A		REVISED ECR-19-019743	02JUN2020	J. J. W. H.

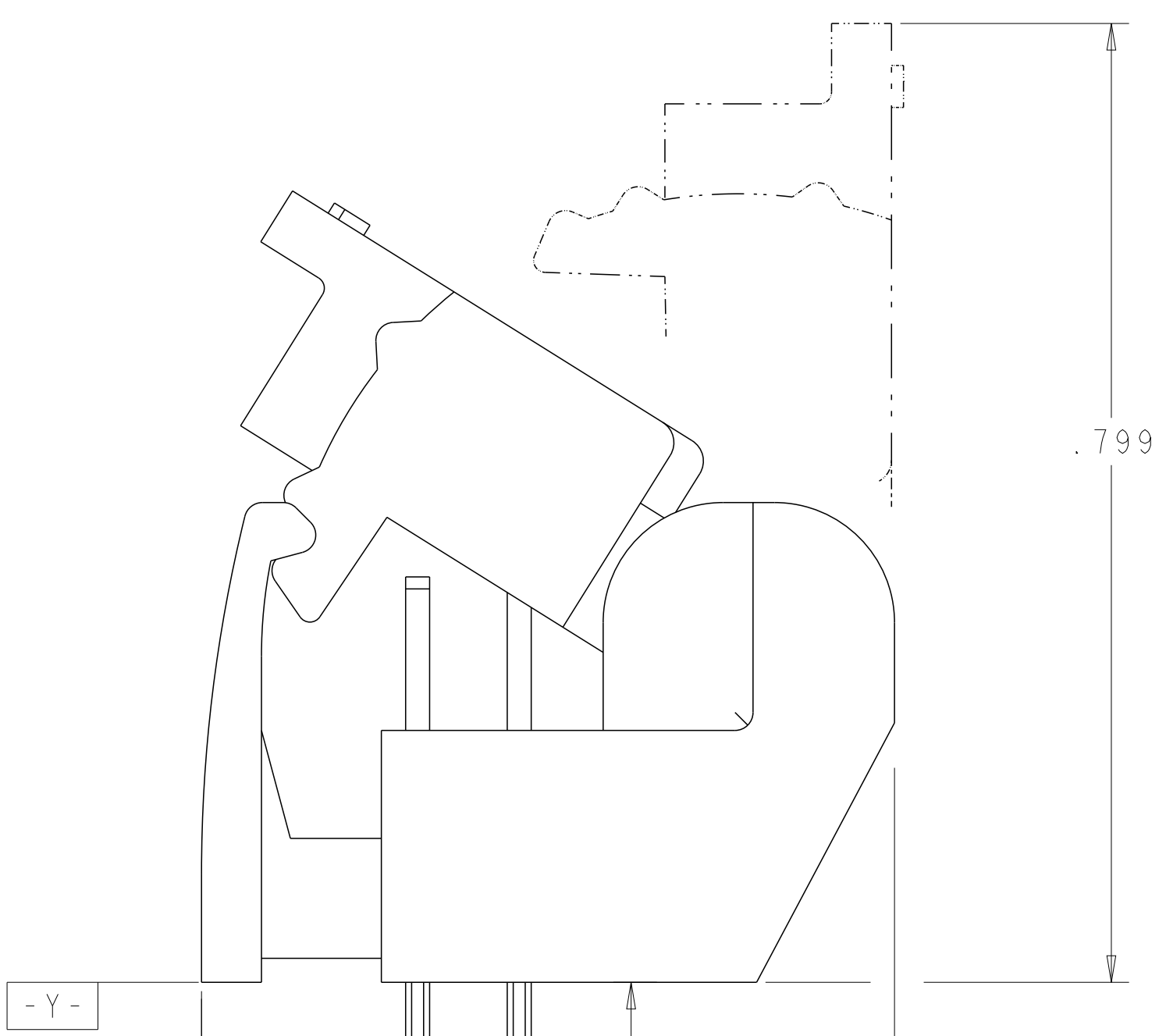

- ⚠ MATERIAL: BASE - POLYESTER MOLDING COMPOUND, BLACK.
WIRE STUFFER: - POLYESTER MOLDING COMPOUND, SEE TABLE FOR COLOR.
TERMINAL - COPPER ALLOY, PLATED WITH 3.81µm MINIMUM THICK TIN OVER 1.27µm MINIMUM THICK NICKEL UNDERPLATE.
- ⚠ EACH WIRE ENTRY HOLE ACCEPTS ONE UNSTRIPPED SOLID COPPER 22-26 AWG WIRE WITH WIRE INSULATION DIAMETER RANGE FROM .060 THROUGH .040. OTHER WIRE SIZES AND TYPES SHALL BE SUBMITTED TO AMP ENGINEERS FOR APPLICATION APPROVAL.
- 3. SOLDER TABS PROVIDED FOR PERMANENT BOARD MOUNTING.
- ⚠ LOCATION OF HOLE PATTERN DETERMINED BASED ON CUSTOMER REQUIREMENTS.

OBSOLETE

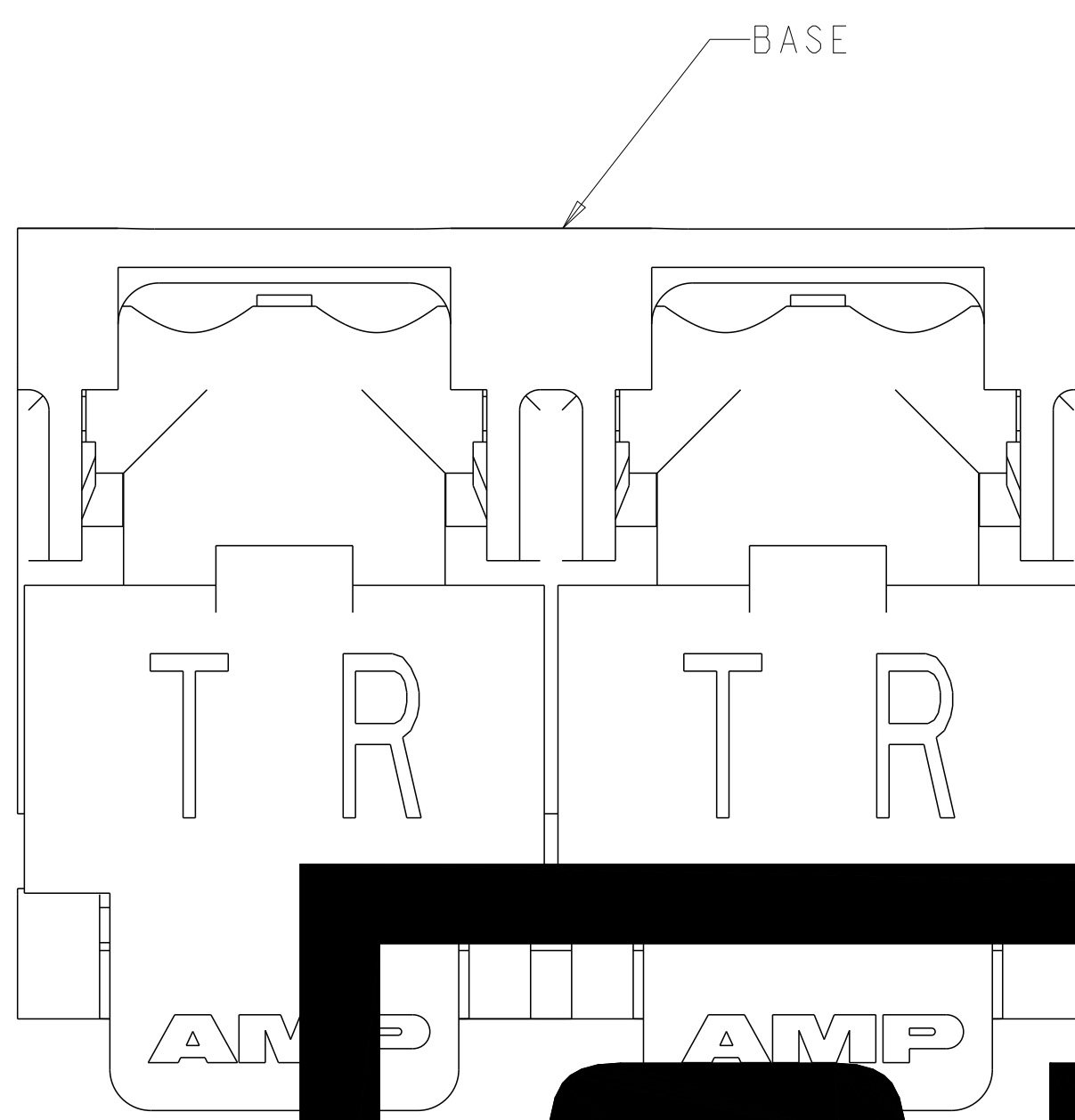
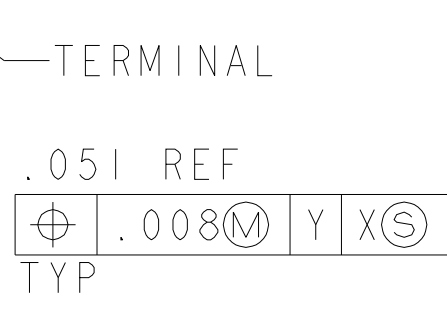
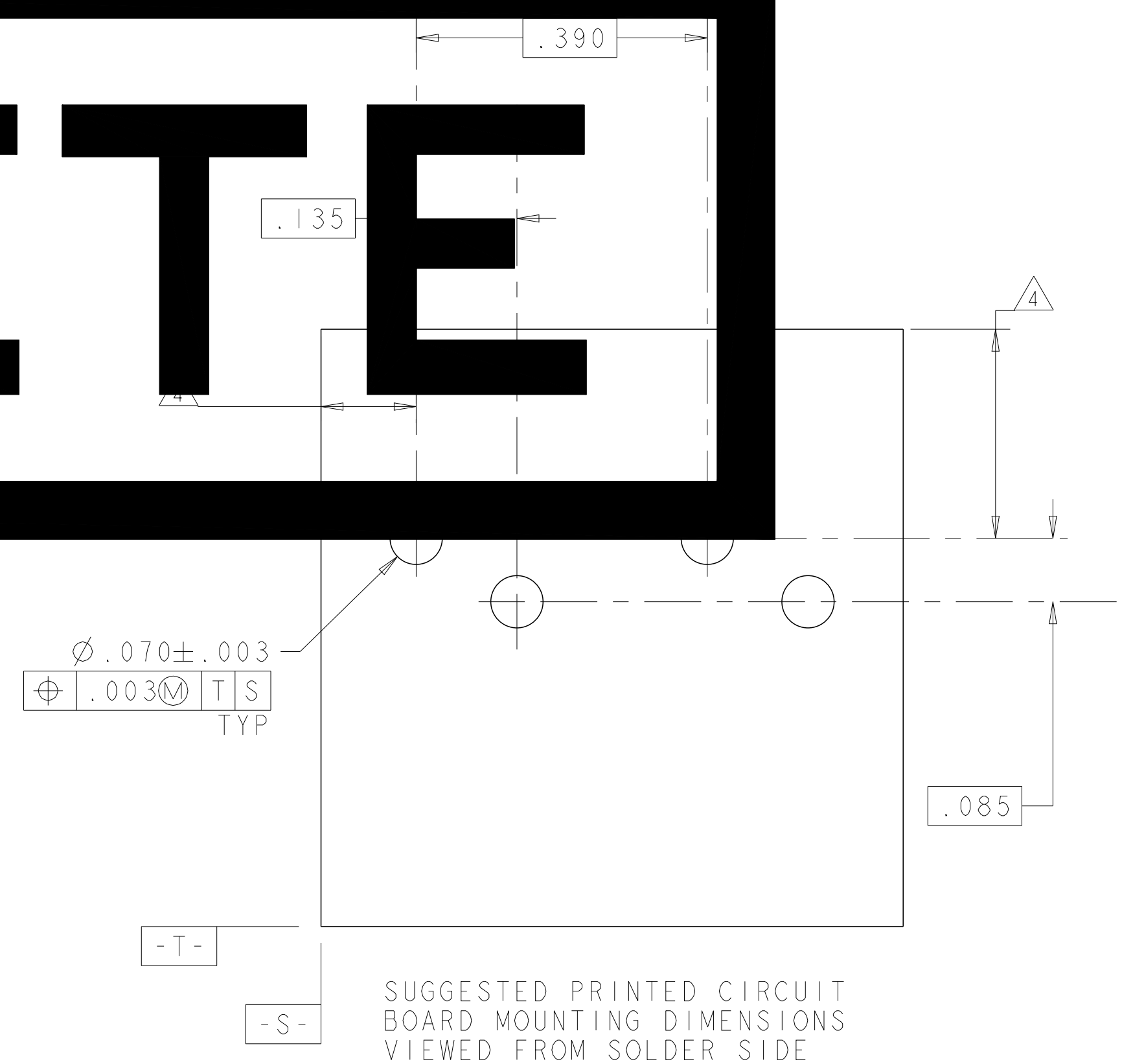
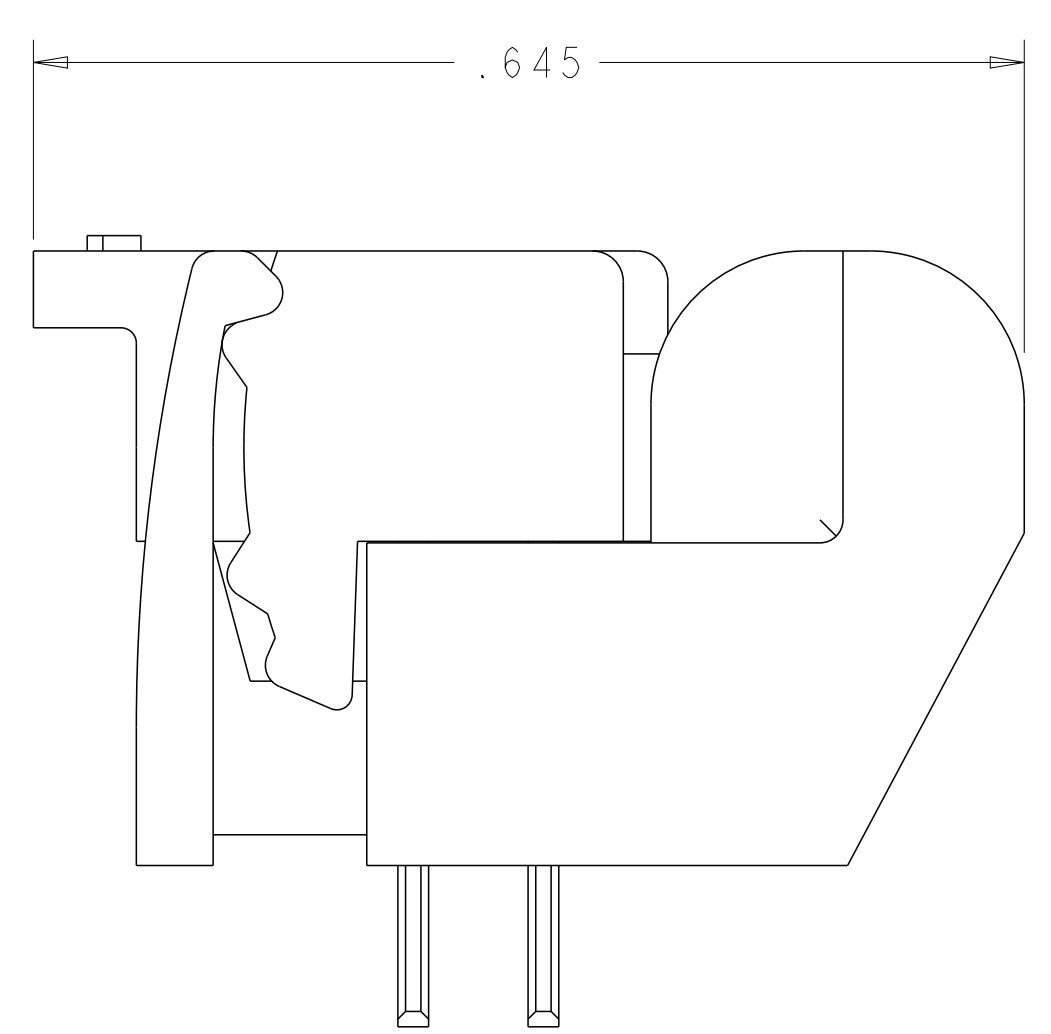
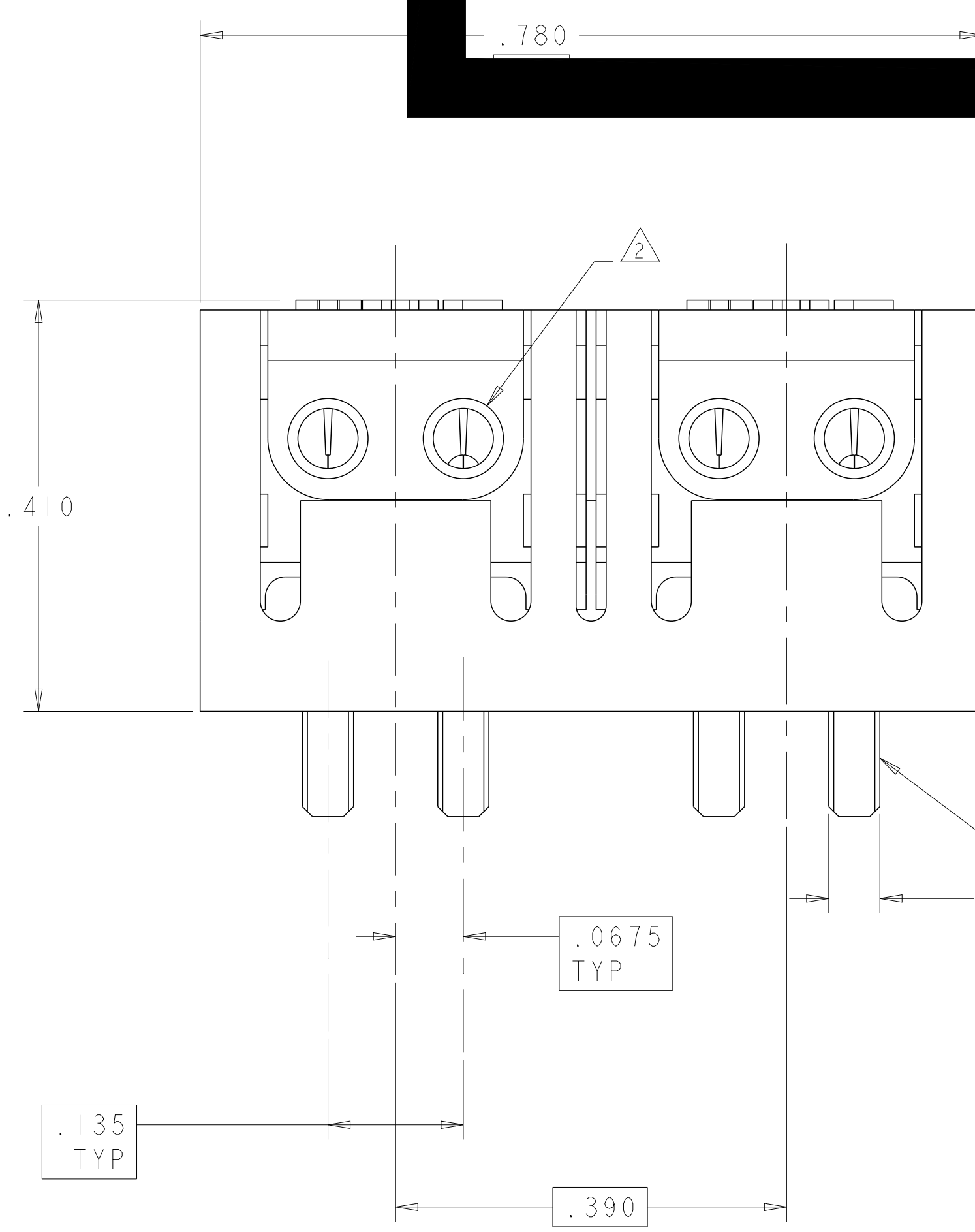

RED	GREEN	CLEAR	1658921-1
R	T	WIRE STUFFER	PART NUMBER
COLOR CODE			

THIS DRAWING IS A CONTROLLED DOCUMENT.		OWN J. BURWELL	26NOV03	
DIMENSIONS: INCHES		CHK		
TOLERANCES UNLESS OTHERWISE SPECIFIED:		APVD C. FULP	26NOV03	NAME ASSEMBLY, DOUBLE PAIR, DOUBLE ENTRY, PIVOT II CONNECTOR
0 PLC ±		PRODUCT SPEC		
1 PLC ±.01		APPLICATION SPEC		SIZE CAGE CODE DRAWING NO
2 PLC ±.005		RESTRICTED TO		
3 PLC ±		WEIGHT		SCALE 6:1
4 PLC ±		SHEET	1	
ANGLES ±2°		FINISH		OF 1
MATERIAL		REV	A	
FINISH		CUSTOMER DRAWING		