

RoHS COMPLIANT BY EXEMPTION

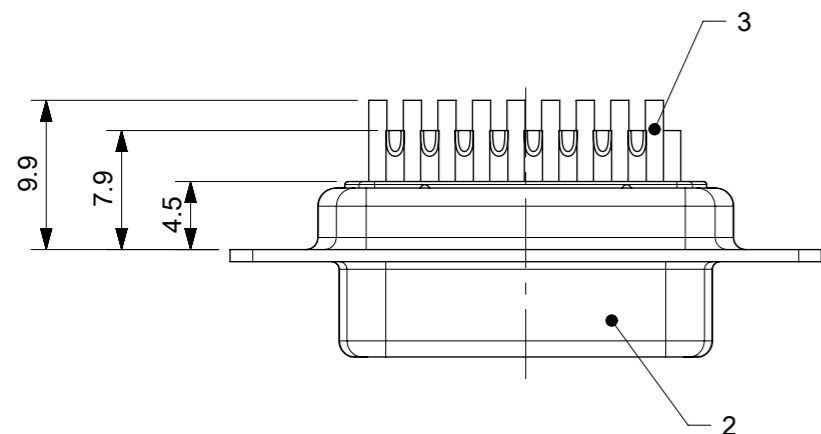
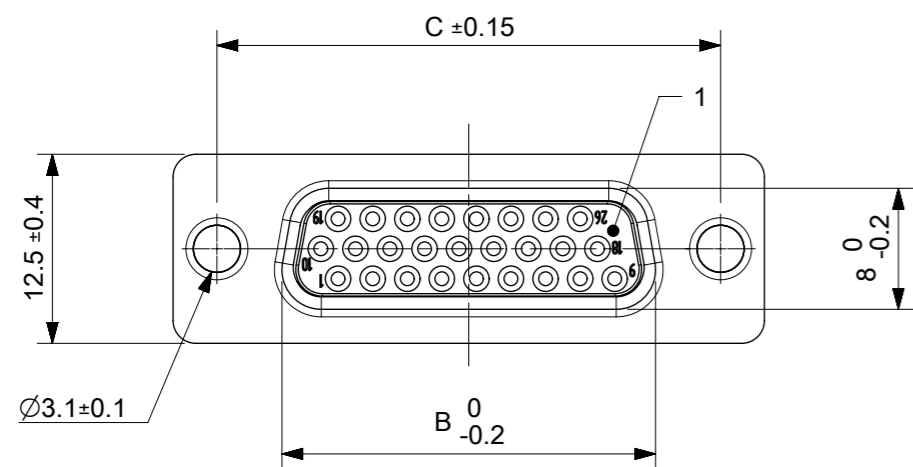

TABLE FOR PART NUMBERS

MOLEX PART#	FCT PART#	X-X	A [mm]	B [mm]	C [mm]	NO. OF CONTACTS 1./2./3. ROW	FORMERLY PART NO
1731130150	F09-15S0G0-0008	09-15	30.8	16.4	25	5/5/5	CT09-15S-2045
1731130151	F15-26S0G0-0008	15-26	39.1	24.7	33.3	9/9/8	CT15-26S-2045

TABLE FOR GENERAL TOLERANCES

PERMISSIBLE DEVIATIONS FOR BASIC SIZE RANGE				
0.5 UPTO	OVER 3 UPTO	OVER 6 UPTO	OVER 30 UPTO	OVER 120 UPTO
3	6	30	120	400
±0.1	±0.1	±0.2	±0.3	±0.5



X-X NO. OF CONTACTS 09-15, 15-26, 25-44

NO.	St.	PART	TYPE DESCRIPTION/MATERIAL	SURFACE PLATING/COLOUR/CLASS
3	X-X	SIGNAL CONTACT, MACHINED	HS0 / BRASS	AWG 22 / 0.8µm Au
2	1	SHELL	STEEL	TIN PLATED
1	1	INSULATOR	PBT (-55°C - +130°C)	BLACK

THIS DRAWING CONTAINS INFORMATION THAT IS PROPRIETARY TO MOLEX ELECTRONIC TECHNOLOGIES, LLC AND SHOULD NOT BE USED WITHOUT WRITTEN PERMISSION

DIMENSION UNITS <b>mm</b>	SCALE <b>2:1</b>	CURRENT REV DESC: OBSOLETE PART NUMBER AS PER PCN#509457.	<b>molex</b>			
GENERAL TOLERANCES (UNLESS SPECIFIED)		EC NO: 680890				HPD HIGH DENSITY D-SUB, SOLDER CUP, WITH MACHINED FEMALE SOCKET CONTACTS
ANGULAR TOL ± °		DRWN: SANTHN 2021/05/27	PRODUCT CUSTOMER DRAWING			
4 PLACES ±		CHK'D: GGA 2021/11/25	DOCUMENT NUMBER			
3 PLACES ±		APPR: GGA 2021/11/25	1731130150			
2 PLACES ±		INITIAL REVISION:	DOC TYPE	DOC PART	REVISION	
1 PLACE ±		DRWN: RLALSANGI 2017/04/13	PSD	000	A1	
0 PLACES ±		APPR: ISHWARG 2017/06/07				
DRAFT WHERE APPLICABLE MUST REMAIN WITHIN DIMENSIONS	THIRD ANGLE PROJECTION	DRAWING A3-SIZE	SERIES 173113	MATERIAL NUMBER SEE TABLE	CUSTOMER GENERAL MARKET	SHEET NUMBER 1 OF 1