

May.1.2023 Copyright 2023 HIROSE ELECTRIC CO., LTD. All Rights Reserved.
In case of consideration for using Automotive equipment / device which demand high reliability, kindly contact our sales window correspondents.

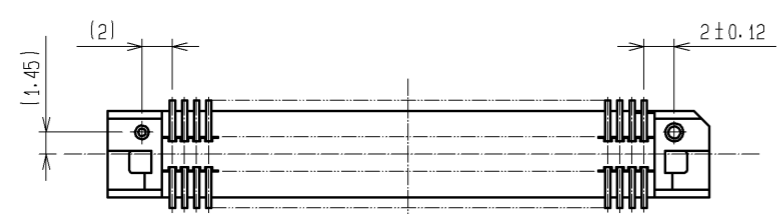

A-A (10:1)

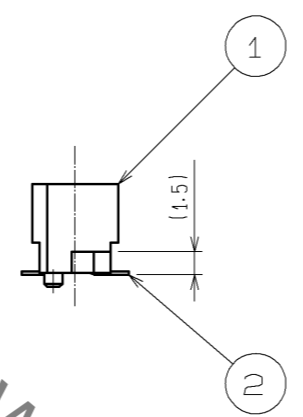
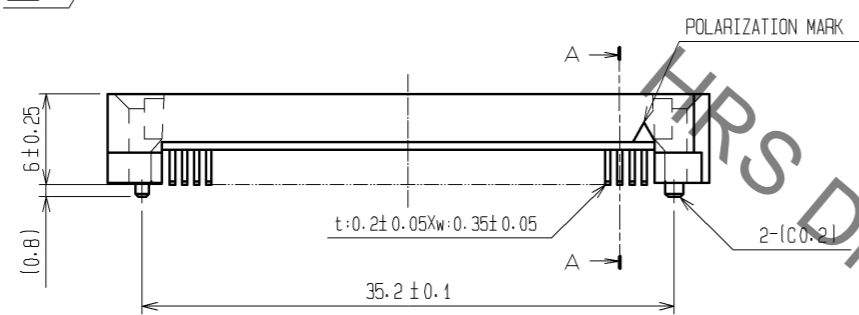
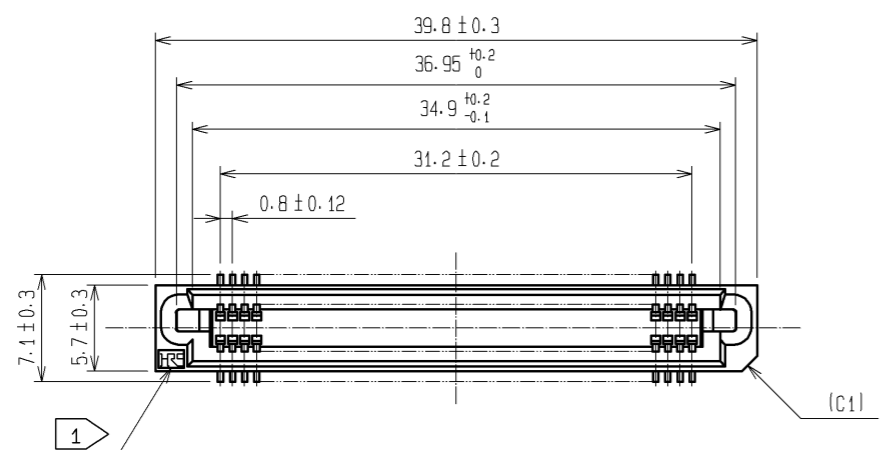
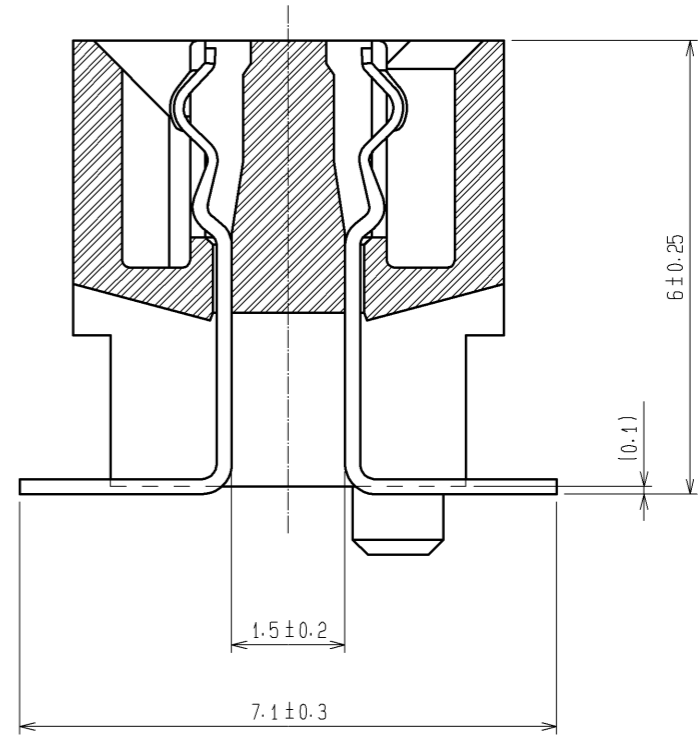

RECOMMENDED LAND PATTERN DIMENSION OF PCB (MOUNTING SIDE)

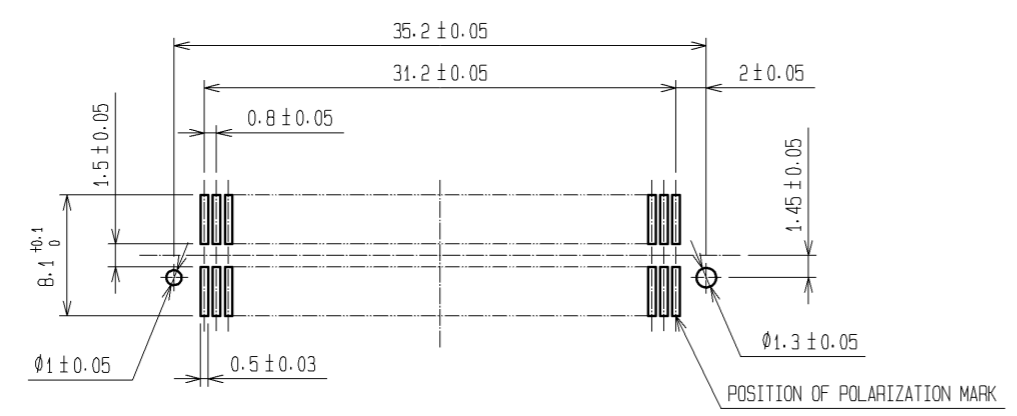

- NOTE
- 1 HRS MARK SHALL BE OPTIONAL.
 - 2 LEAD CO-PLANARITY SHALL BE 0.1mm MAX.
 - 3 EMBOSSED CARRIER TAPE PACKAGING SHALL BE APPLIED FOR THIS PRODUCT. SEE NEXT PAGE FOR DETAILS.
 - 4 THIS PRODUCT HAS TAPE FOR VACUUM PICKUP. SEE NEXT PAGE FOR DETAIL OF STICKING POSITION, ETC.
 - 5 FOR MODIFICATION, ETC., PREVENTIVE HOLE FOR SINK MARK MAY BE ADDED ACCORDING TO CIRCUMSTANCES.
 - 6 THE DIMENSIONS IN PARENTHESES ARE FOR REFERENCE.

1	PPS	LIGHT BROWN (UL94V-0)	2	PHOSPHOR BRONZE	CONTACT AREA: GOLD 0.1µm min. LEAD AREA: TIN-PLATING 1µm min. UNDER PLATING: NICKEL 2µm min.		
NO.	MATERIAL	FINISH . REMARKS	NO.	MATERIAL	FINISH . REMARKS		
UNITS mm		SCALE 2 : 1	COUNT 	DESCRIPTION OF REVISIONS	DESIGNED	CHECKED	DATE
HRS HIROSE ELECTRIC CO., LTD.		APPROVED : HS. OKAWA	07.06.20	DRAWING NO.	EDC3-084984-23		
		CHECKED : HS. OZAWA	07.06.20	PART NO.	FX6-80S-0.8SV2(93)		
		DESIGNED : KT. DOI	07.06.20	CODE NO.	CL576-0127-1-93		
		DRAWN : TS. MIYAKI	07.06.14				

May.1.2023 Copyright 2023 HIROSE ELECTRIC CO., LTD. All Rights Reserved.
 In case of consideration for using Automotive equipment / device which demand high reliability, kindly contact our sales window correspondents.

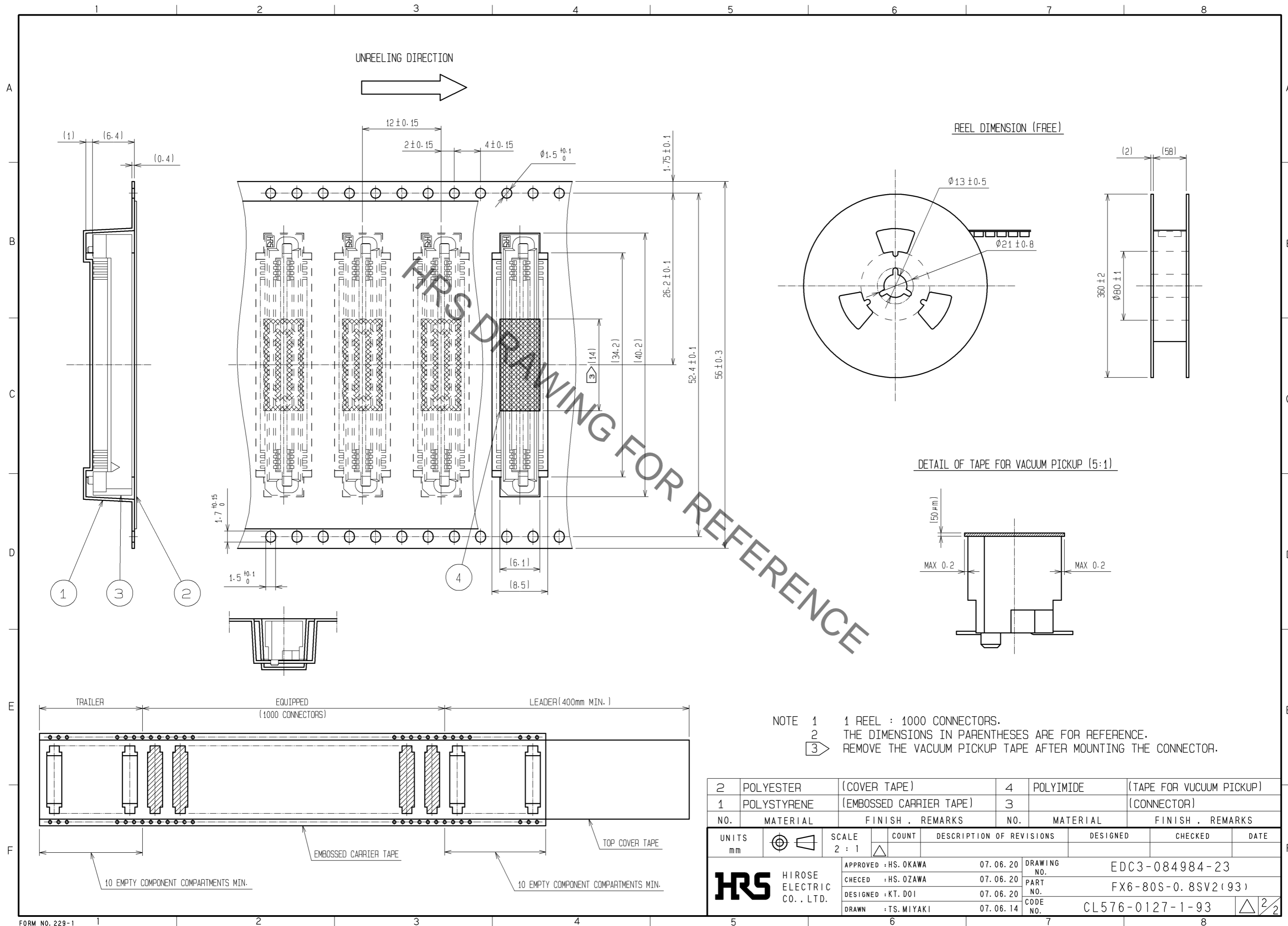

2	POLYESTER	(COVER TAPE)	4	POLYIMIDE	(TAPE FOR VUCUUM PICKUP)
1	POLYSTYRENE	(EMBOSSED CARRIER TAPE)	3		(CONNECTOR)
NO.	MATERIAL	FINISH . REMARKS	NO.	MATERIAL	FINISH . REMARKS
UNITS mm		SCALE 2 : 1	COUNT 	DESCRIPTION OF REVISIONS	
APPROVED : HS. OKAWA		07.06.20		DESIGNED	CHECKED
CHECED : HS. OZAWA		07.06.20		DATE	
DESIGNED : KT. DOI		07.06.20		DRAWING NO. EDC3-084984-23	
DRAWN : TS. MIYAKI		07.06.14		PART NO. FX6-80S-0.8SV2(93)	
HRS HIROSE ELECTRIC CO., LTD.				CODE NO. CL576-0127-1-93	