

# TVS Diodes

Transient Voltage Suppressor Diodes

## ESD18VU1B-02LRH

ESD / Transient Protection Diode for Near Field Communication (NFC)

ESD18VU1B-02LRH

## Data Sheet

Revision 1.4, 2013-08-07  
Final

**Edition 2013-08-07**

**Published by  
Infineon Technologies AG  
81726 Munich, Germany**

**© 2013 Infineon Technologies AG  
All Rights Reserved.**

### **Legal Disclaimer**

The information given in this document shall in no event be regarded as a guarantee of conditions or characteristics. With respect to any examples or hints given herein, any typical values stated herein and/or any information regarding the application of the device, Infineon Technologies hereby disclaims any and all warranties and liabilities of any kind, including without limitation, warranties of non-infringement of intellectual property rights of any third party.

### **Information**

For further information on technology, delivery terms and conditions and prices, please contact the nearest Infineon Technologies Office ([www.infineon.com](http://www.infineon.com)).

### **Warnings**

Due to technical requirements, components may contain dangerous substances. For information on the types in question, please contact the nearest Infineon Technologies Office.

Infineon Technologies components may be used in life-support devices or systems only with the express written approval of Infineon Technologies, if a failure of such components can reasonably be expected to cause the failure of that life-support device or system or to affect the safety or effectiveness of that device or system. Life support devices or systems are intended to be implanted in the human body or to support and/or maintain and sustain and/or protect human life. If they fail, it is reasonable to assume that the health of the user or other persons may be endangered.

**Revision History: Revision 1.3, 2013-06-26**

Page or Item	Subjects (major changes since previous revision)
<b>Revision 1.4, 2013-08-07</b>	
7 - 10	Figure 5) - Figure 9) updated

**Trademarks of Infineon Technologies AG**

AURIX™, BlueMoon™, COMNEON™, C166™, CROSSAVE™, CanPAK™, CIPOS™, CoolMOS™, CoolSET™, CORECONTROL™, DAVE™, EasyPIM™, EconoBRIDGE™, EconoDUAL™, EconoPACK™, EconoPIM™, EiceDRIVER™, EUPEC™, FCOS™, HITFET™, HybridPACK™, ISOFACE™, I<sup>2</sup>RF™, IsoPACK™, MIPAQ™, ModSTACK™, my-d™, NovalithIC™, OmniTune™, OptiMOS™, ORIGA™, PROFET™, PRO-SIL™, PRIMARION™, PrimePACK™, RASIC™, ReverSave™, SatRIC™, SIEGET™, SINDRION™, SMARTi™, SmartLEWIS™, TEMPFET™, thinQ!™, TriCore™, TRENCHSTOP™, X-GOLD™, XMM™, X-PMU™, XPOSYS™.

**Other Trademarks**

Advance Design System™ (ADS) of Agilent Technologies, AMBA™, ARM™, MULTI-ICE™, PRIMECELL™, REALVIEW™, THUMB™ of ARM Limited, UK. AUTOSAR™ is licensed by AUTOSAR development partnership. Bluetooth™ of Bluetooth SIG Inc. CAT-iq™ of DECT Forum. COLOSSUS™, FirstGPS™ of Trimble Navigation Ltd. EMV™ of EMVCo, LLC (Visa Holdings Inc.). EPCOS™ of Epcos AG. FLEXGO™ of Microsoft Corporation. FlexRay™ is licensed by FlexRay Consortium. HYPERTERMINAL™ of Hilgraeve Incorporated. IEC™ of Commission Electrotechnique Internationale. IrDA™ of Infrared Data Association Corporation. ISO™ of INTERNATIONAL ORGANIZATION FOR STANDARDIZATION. MATLAB™ of MathWorks, Inc. MAXIM™ of Maxim Integrated Products, Inc. MICROTEC™, NUCLEUS™ of Mentor Graphics Corporation. Mifare™ of NXP. MIPI™ of MIPI Alliance, Inc. MIPS™ of MIPS Technologies, Inc., USA. muRata™ of MURATA MANUFACTURING CO., MICROWAVE OFFICE™ (MWO) of Applied Wave Research Inc., OmniVision™ of OmniVision Technologies, Inc. Openwave™ Openwave Systems Inc. RED HAT™ Red Hat, Inc. RFMD™ RF Micro Devices, Inc. SIRIUS™ of Sirius Sattelite Radio Inc. SOLARIS™ of Sun Microsystems, Inc. SPANSION™ of Spansion LLC Ltd. Symbian™ of Symbian Software Limited. TAIYO YUDEN™ of Taiyo Yuden Co. TEAKLITE™ of CEVA, Inc. TEKTRONIX™ of Tektronix Inc. TOKO™ of TOKO KABUSHIKI KAISHA TA. UNIX™ of X/Open Company Limited. VERILOG™, PALLADIUM™ of Cadence Design Systems, Inc. VLYNQ™ of Texas Instruments Incorporated. VXWORKS™, WIND RIVER™ of WIND RIVER SYSTEMS, INC. ZETEX™ of Diodes Zetex Limited.

Last Trademarks Update 2010-06-09

# 1 ESD / Transient Protection Diode for Near Field Communication (NFC)

## 1.1 Features

- ESD / transient protection according to:
  - IEC61000-4-2 (ESD):  $\pm 15$  kV air discharge,  $\pm 12$  kV contact discharge
  - IEC61000-4-5 (surge):  $\pm 2$  A ( $t_p = 8 / 20 \mu s$ )
- AC working voltage up to  $\pm 18.5$  V ( $V_{TRIG \min} = 20$  V)
- Ultra-low capacitance:  $C_L = 0.3$  pF (typical)
- Small leadless plastic package, size 0402
- Pb-free (RoHS compliant) and halogen free package



## 1.2 Application Examples

- ESD Protection of RF signal lines in Near Field Communication (NFC) applications

## 1.3 Product Description

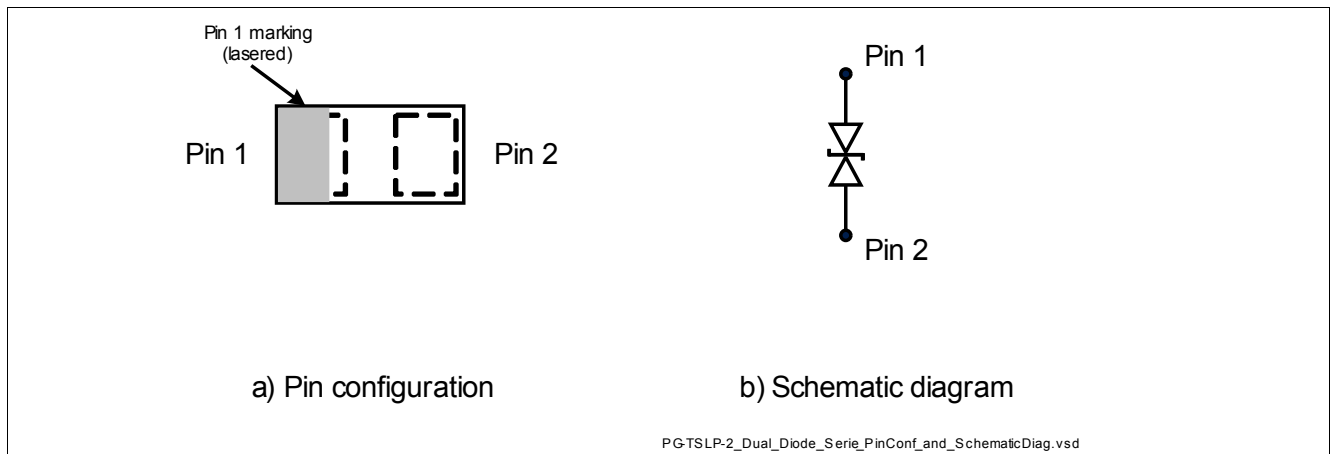

Figure 1 Pin Configuration and Schematic Diagram

Table 1 Ordering Information

Type	Package	Configuration	Marking code
ESD18VU1B-02LRH	TSLP-2-17	1 line, bi-directional	X

## 2 Characteristics

**Table 2** Maximum Rating at  $T_A = 25\text{ °C}$ , unless otherwise specified

Parameter	Symbol	Values			Unit
		Min.	Typ.	Max.	
ESD air discharge <sup>1)</sup>	$V_{ESD}$	–	–	±15	kV
ESD contact discharge <sup>1)</sup>	$V_{ESD}$	–	–	±12	kV
Peak pulse current ( $t_p = 8 / 20\ \mu\text{s}$ ) <sup>2)</sup>	$I_{PP}$	–	–	±2	A
Operating temperature	$T_{OP}$	-40	–	85	°C
Storage temperature	$T_{stg}$	-55	–	150	°C

1)  $V_{ESD}$  according to IEC61000-4-2

2)  $I_{PP}$  according to IEC61000-4-5

**Attention:** Stresses above the max. values listed here may cause permanent damage to the device. Exposure to absolute maximum rating conditions for extended periods may affect device reliability. Maximum ratings are absolute ratings; exceeding only one of these values may cause irreversible damage to the integrated circuit.

### 2.1 Electrical Characteristics at $T_A = 25\text{ °C}$ , unless otherwise specified

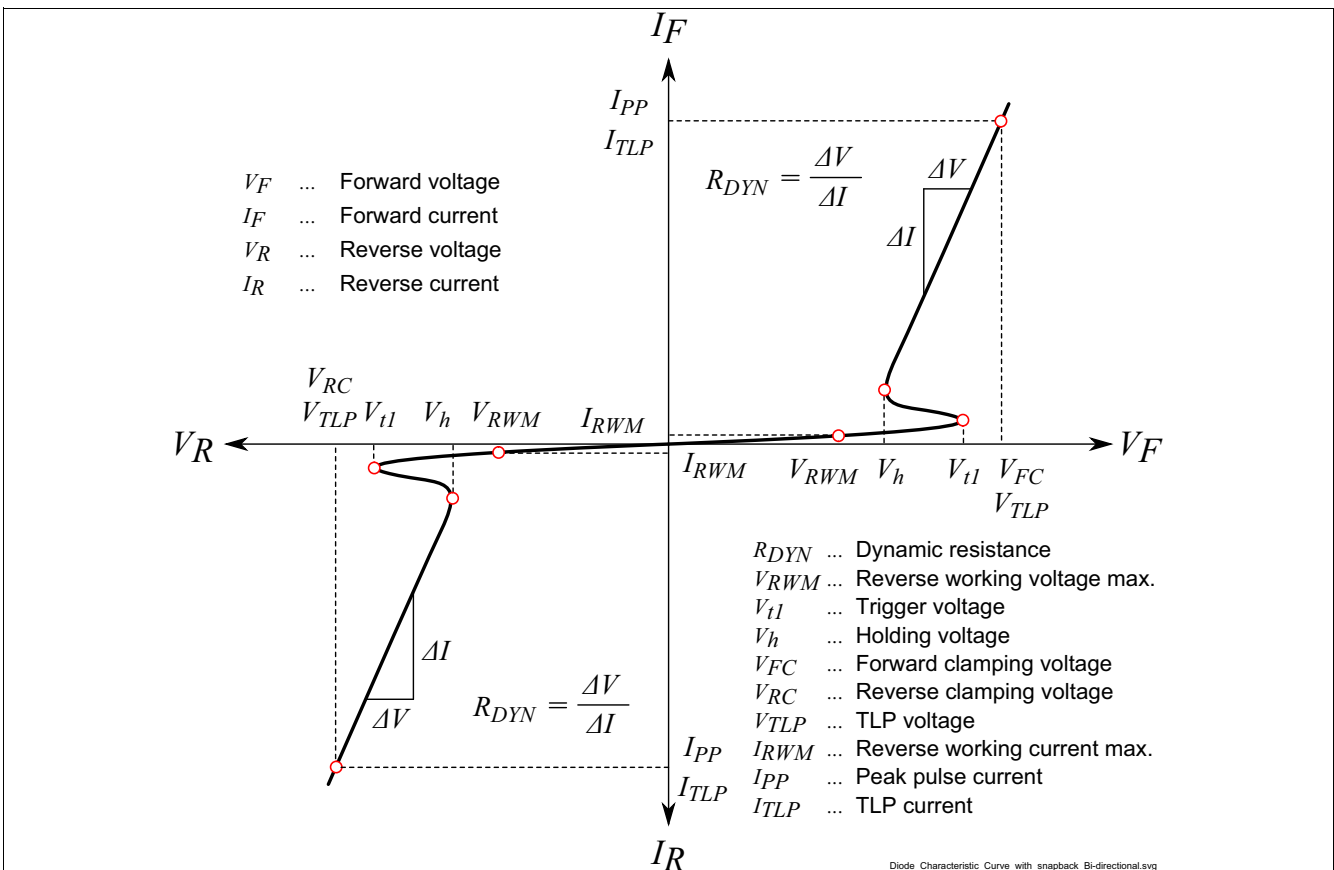

**Figure 2** Definitions of electrical characteristics

**Characteristics**
**Table 3 AC Characteristics at  $T_A = 25\text{ }^\circ\text{C}$ , unless otherwise specified**

Parameter	Symbol	Values			Unit	Note / Test Condition
		Min.	Typ.	Max.		
AC working voltage	$V_{RWM}$	–	–	18.5	V	Both directions
AC trigger voltage	$V_{TRIG}$	20	–	–	V	Both directions
AC reverse current	$I_R$	–	–	30	nA	$V_R = 18.5\text{ V}$ Both directions
		–	–	1	mA	$V_R = 20\text{ V}$ Both directions

**Table 4 RF Characteristics at  $T_A = 25\text{ }^\circ\text{C}$ , unless otherwise specified**

Parameter	Symbol	Values			Unit	Note / Test Condition
		Min.	Typ.	Max.		
Line capacitance <sup>1)</sup>	$C_L$	0.15	0.3	0.6	pF	$V_R = 0\text{ V}, f = 1\text{ MHz}$
		0.15	0.3	0.6	pF	$V_R = 0\text{ V}, f = 1\text{ GHz}$
Serie inductance	$L_S$	–	0.4	–	nH	

1) Total capacitance I/O to *GND*

**Table 5 ESD Characteristics at  $T_A = 25\text{ }^\circ\text{C}$ , unless otherwise specified**

Parameter	Symbol	Values			Unit	Note / Test Condition
		Min.	Typ.	Max.		
Clamping voltage <sup>1)</sup>	$V_{CL}$	–	28	–	V	$I_{TLP} = 16\text{ A},$ $t_p = 100\text{ ns}$
		–	34	–		$I_{TLP} = 25\text{ A},$ $t_p = 100\text{ ns}$
Clamping voltage <sup>2)</sup>	$V_{CL}$	–	17	–	V	$I_{PP} = 1\text{ A},$ $t_p = 8 / 20\text{ }\mu\text{s}$
Dynamic resistance <sup>1)</sup>	$R_{DYN}$	–	0.6	–	$\Omega$	

1) Please refer to Application Note AN210 [1]. TLP parameter:  $Z_0 = 50\text{ }\Omega$ ,  $t_p = 100\text{ ns}$ ,  $t_r = 300\text{ ps}$ , averaging window:  $t_1 = 30\text{ ns}$  to  $t_2 = 60\text{ ns}$ , extraction of dynamic resistance using least squares fit of TLP characteristics between  $I_{TLP1} = 5\text{ A}$  and  $I_{TLP2} = 30\text{ A}$

2)  $I_{PP}$  according to IEC61000-4-5

2.2 Typical Characteristics at  $T_A = 25\text{ }^\circ\text{C}$ , unless otherwise specified

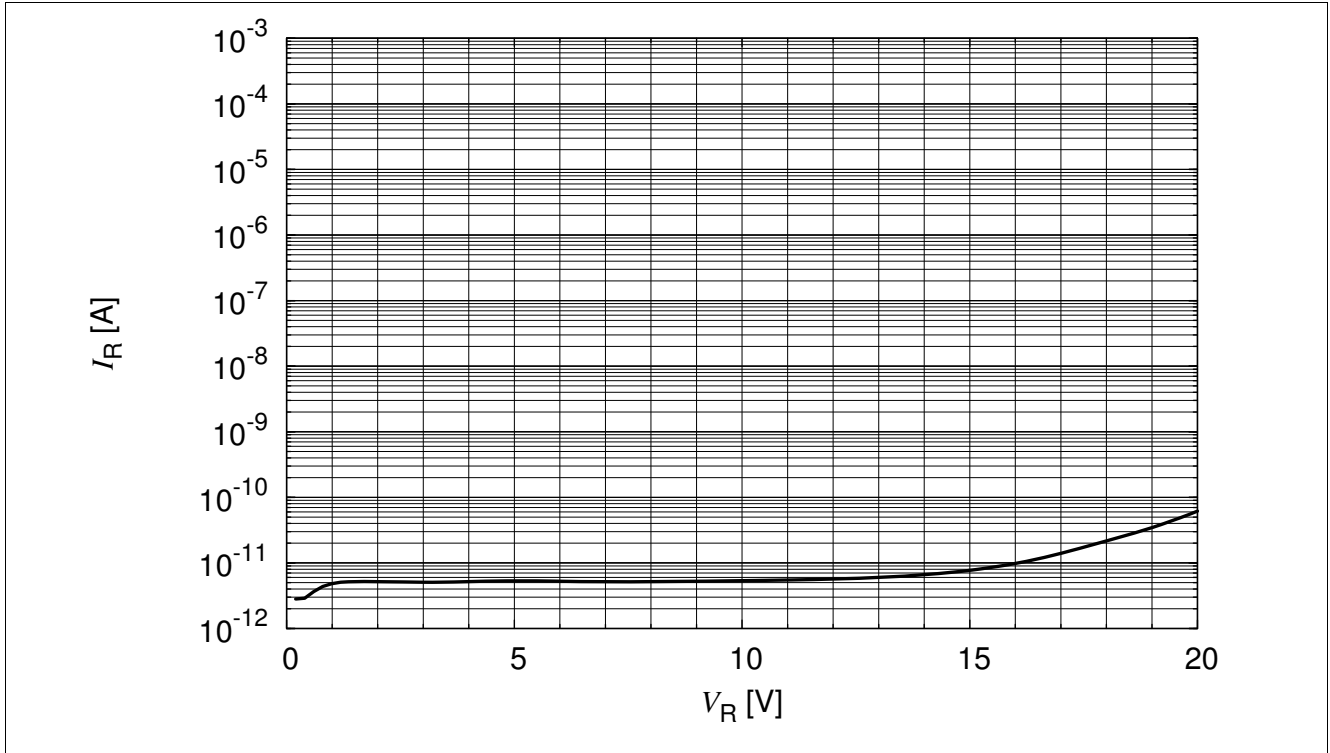

Figure 3 Reverse current:  $I_R = f(V_R)$

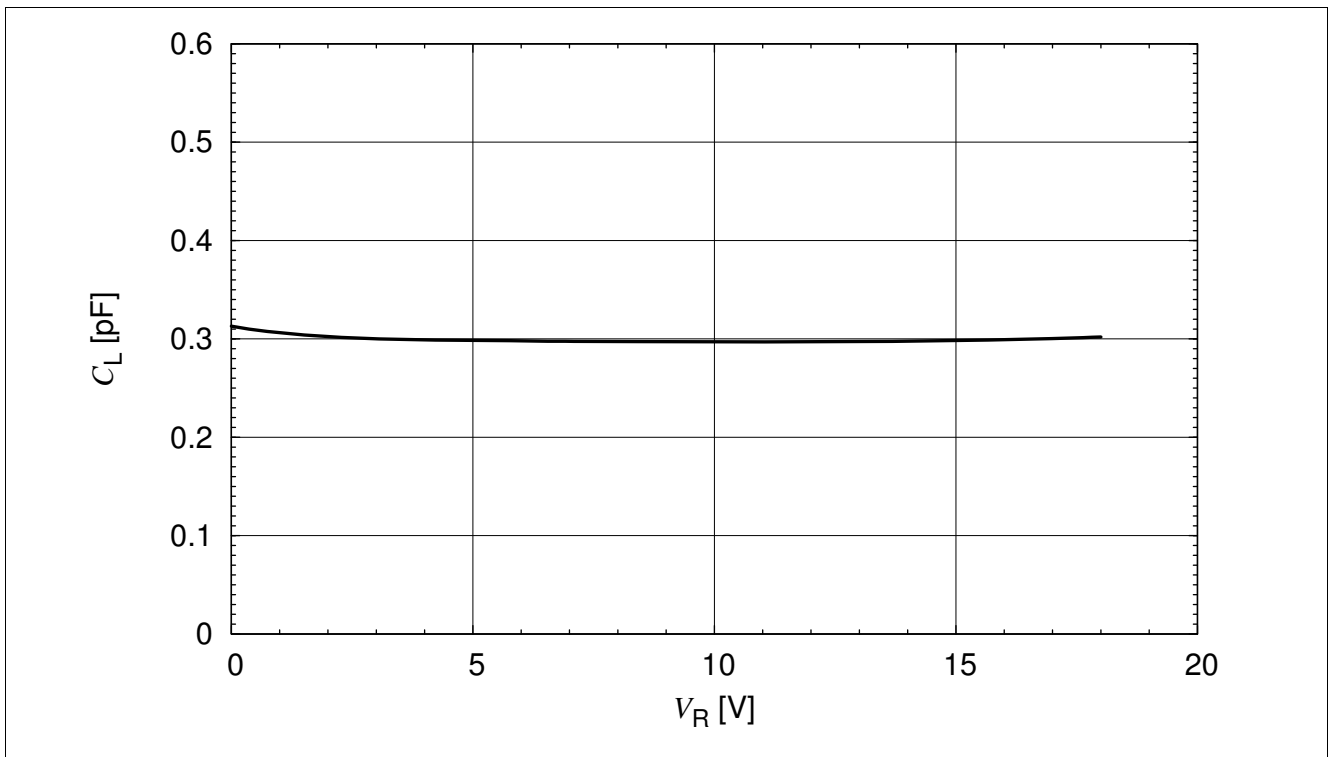
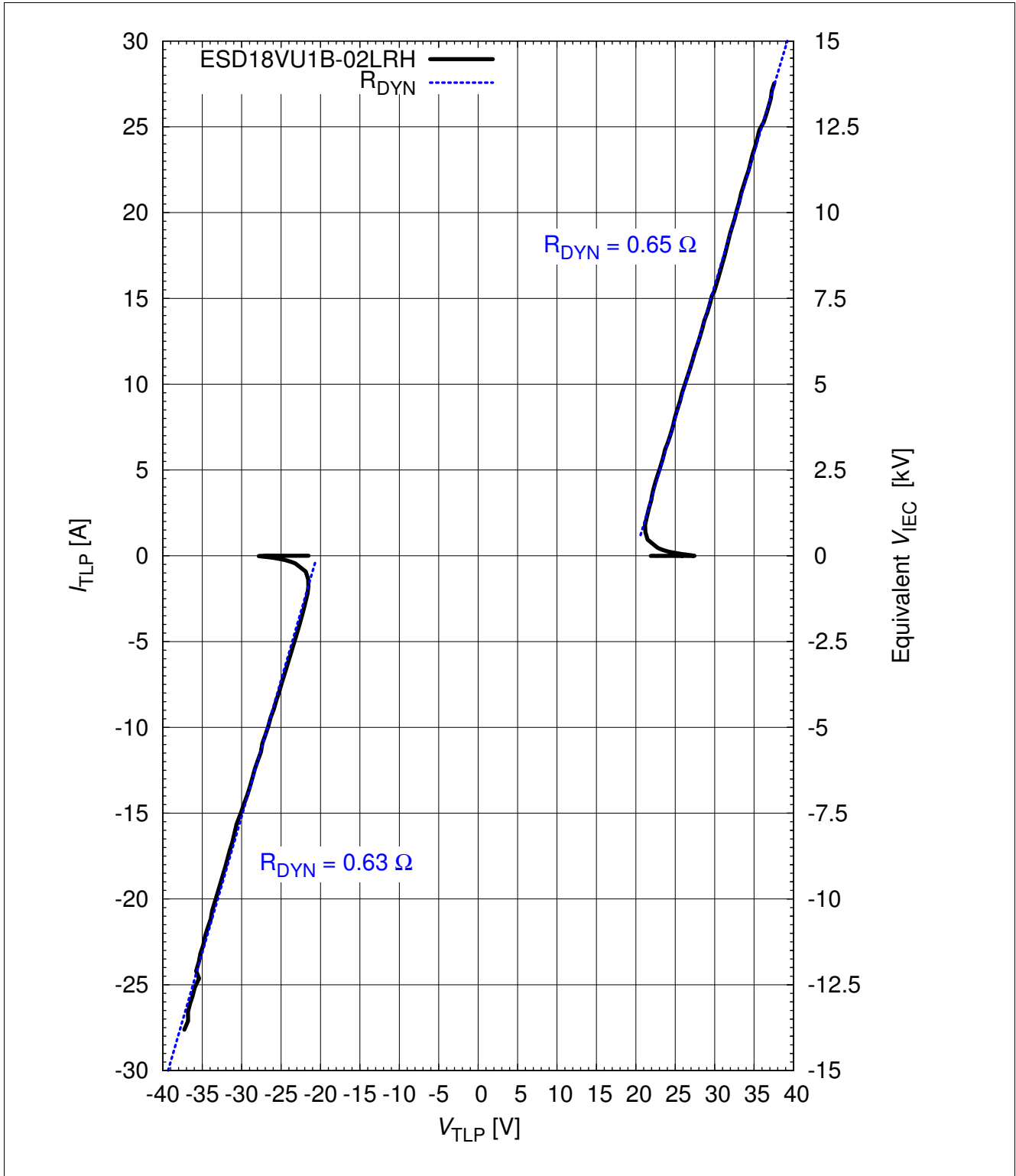

Figure 4 Line capacitance:  $C_L = f(V_R), f = 1\text{ MHz}$



**Figure 5** Clamping voltage (TLP):  $I_{TLP} = f(V_{TLP})$  according ANSI/ESD STM5.5.1- Electrostatic Discharge Sensitivity Testing using Transmission Line Pulse (TLP) Model. TLP conditions:  $Z_0 = 50 \Omega$ ,  $t_p = 100 \text{ ns}$ ,  $t_r = 0.6 \text{ ns}$ ,  $I_{TLP}$  and  $V_{TLP}$  averaging window:  $t_1 = 30 \text{ ns}$  to  $t_2 = 60 \text{ ns}$ , extraction of dynamic resistance using squares fit to ELP characteristic between  $I_{TLP1} = 5 \text{ A}$  and  $I_{TLP2} = 30 \text{ A}$ . Please refer to Application Note AN210 [1]



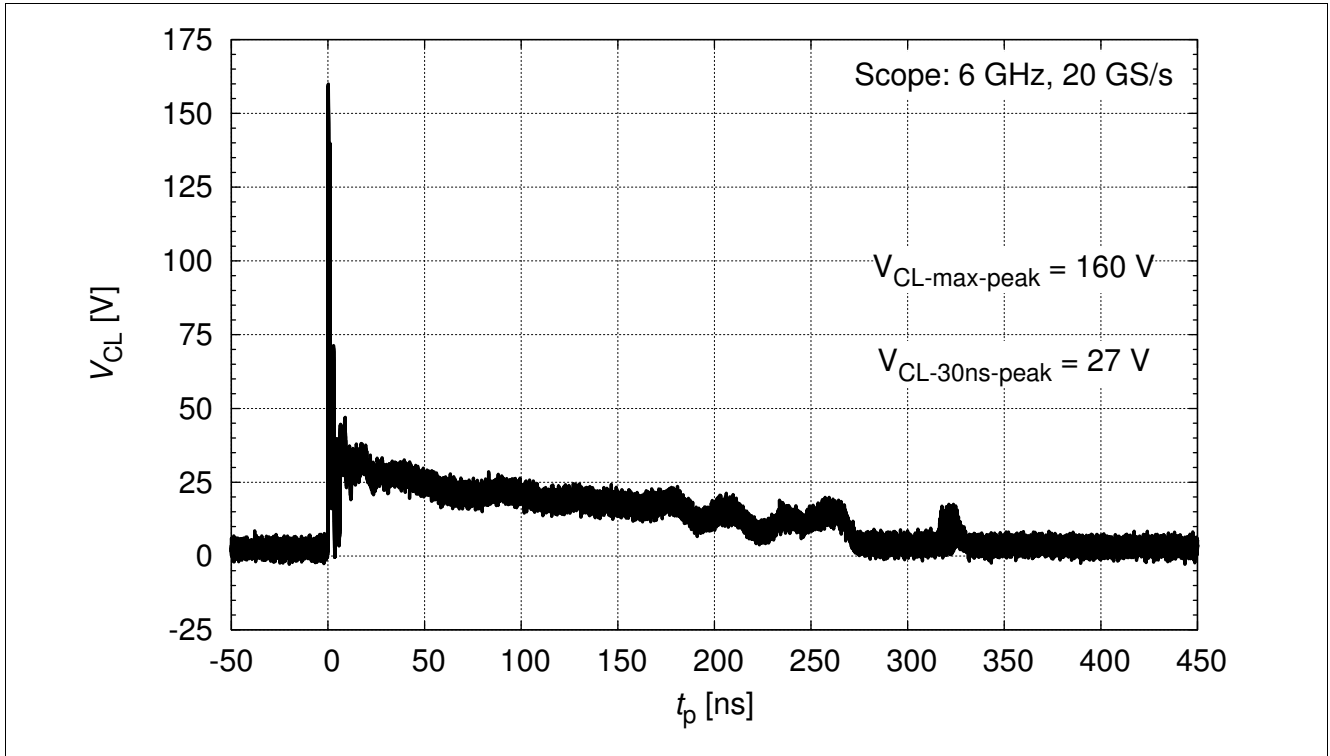

Figure 6 IEC61000-4-2  $V_{CL} = f(t)$ , 8 kV positiv pulse from pin 1 to pin 2

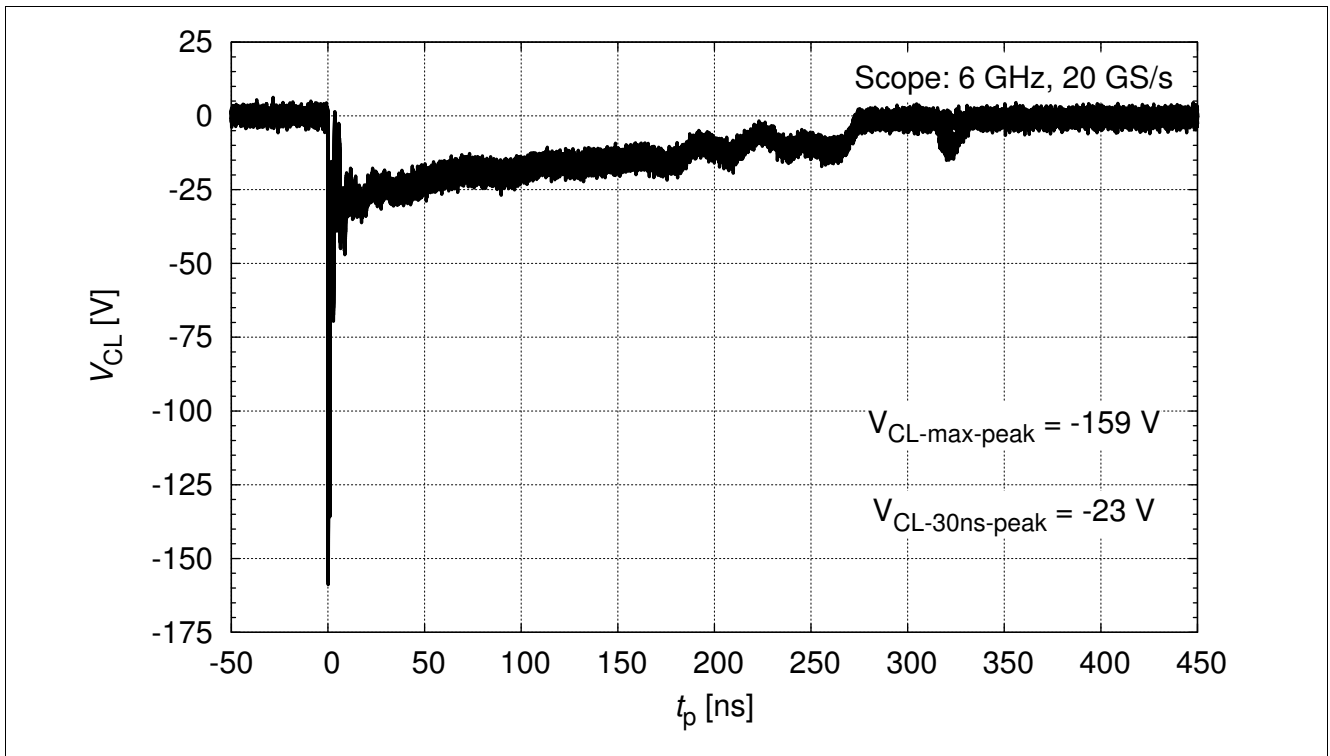

Figure 7 IEC61000-4-2  $V_{CL} = f(t)$ , 8 kV negativ pulse from pin 1 to pin 2

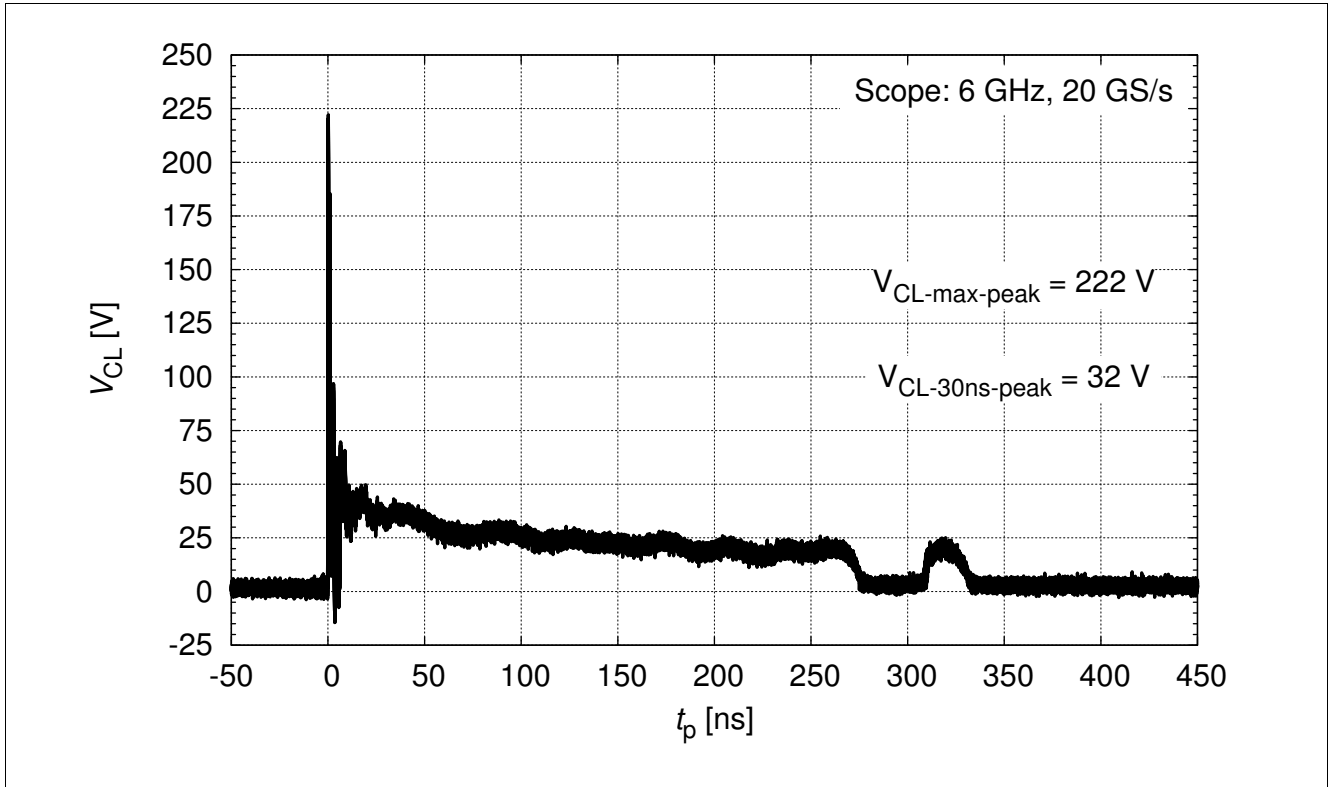

Figure 8 IEC61000-4-2  $V_{CL} = f(t)$ , 15 kV positiv pulse from pin 1 to pin 2

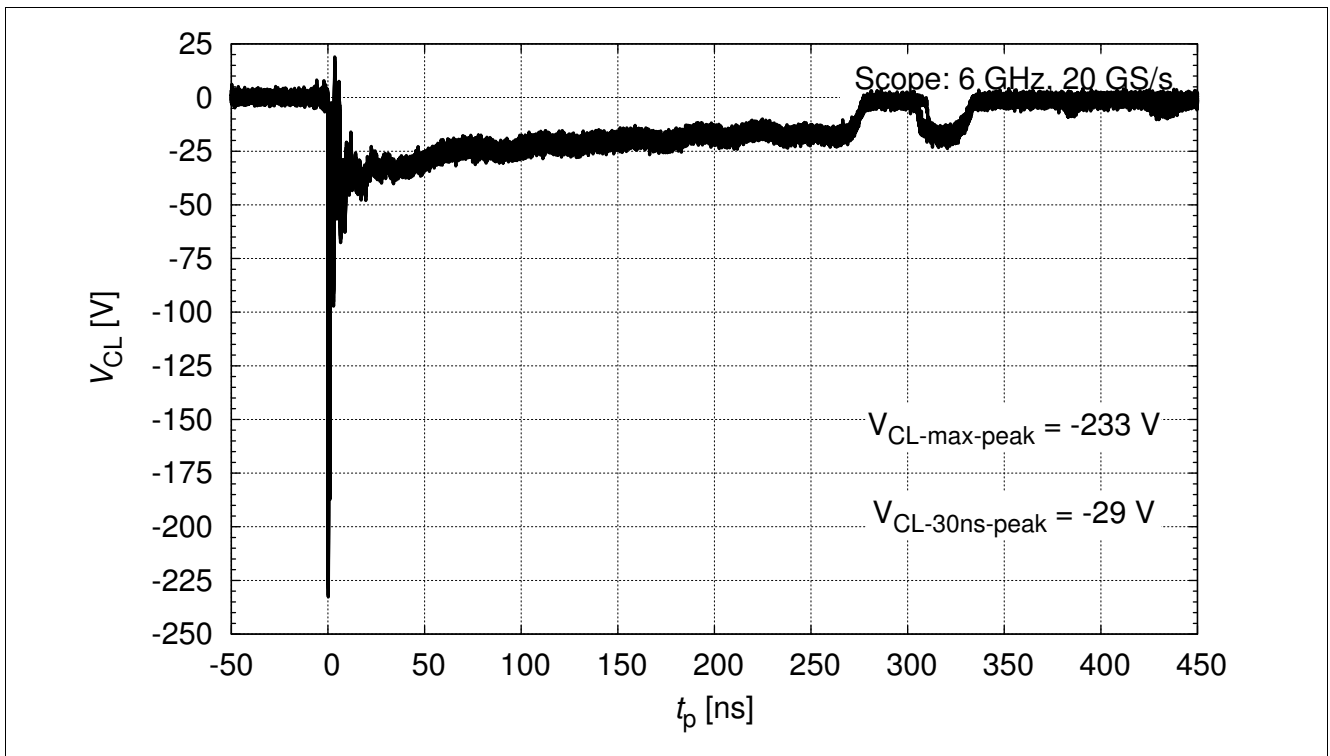

Figure 9 IEC61000-4-2  $V_{CL} = f(t)$ , 15 kV negativ pulse from pin 1 to pin 2

### 3 Application Information

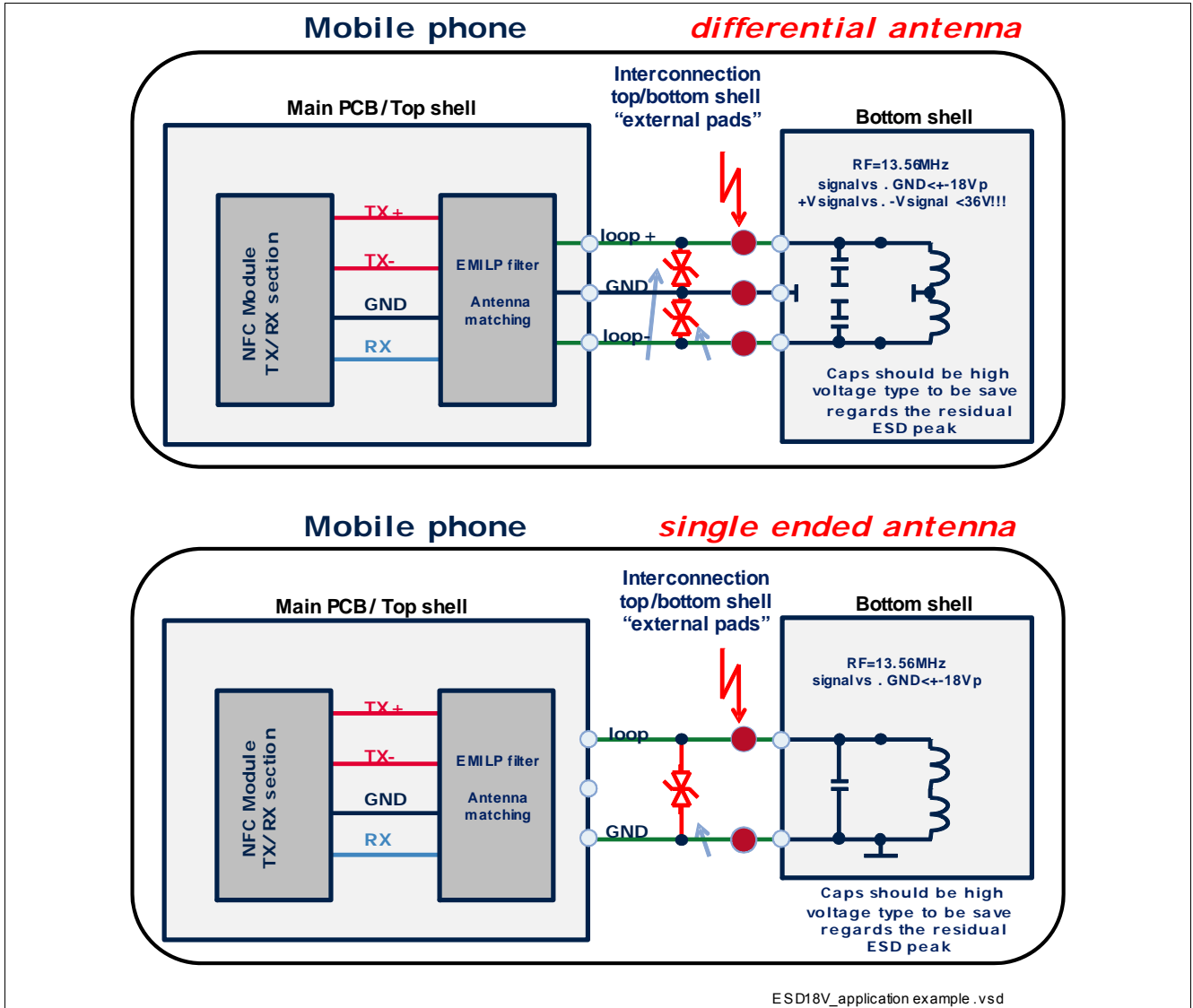

Figure 10 Bi-directional ESD / Transient protection for NFC Frontend [3]

#### 4 Ordering Information Scheme (Examples)

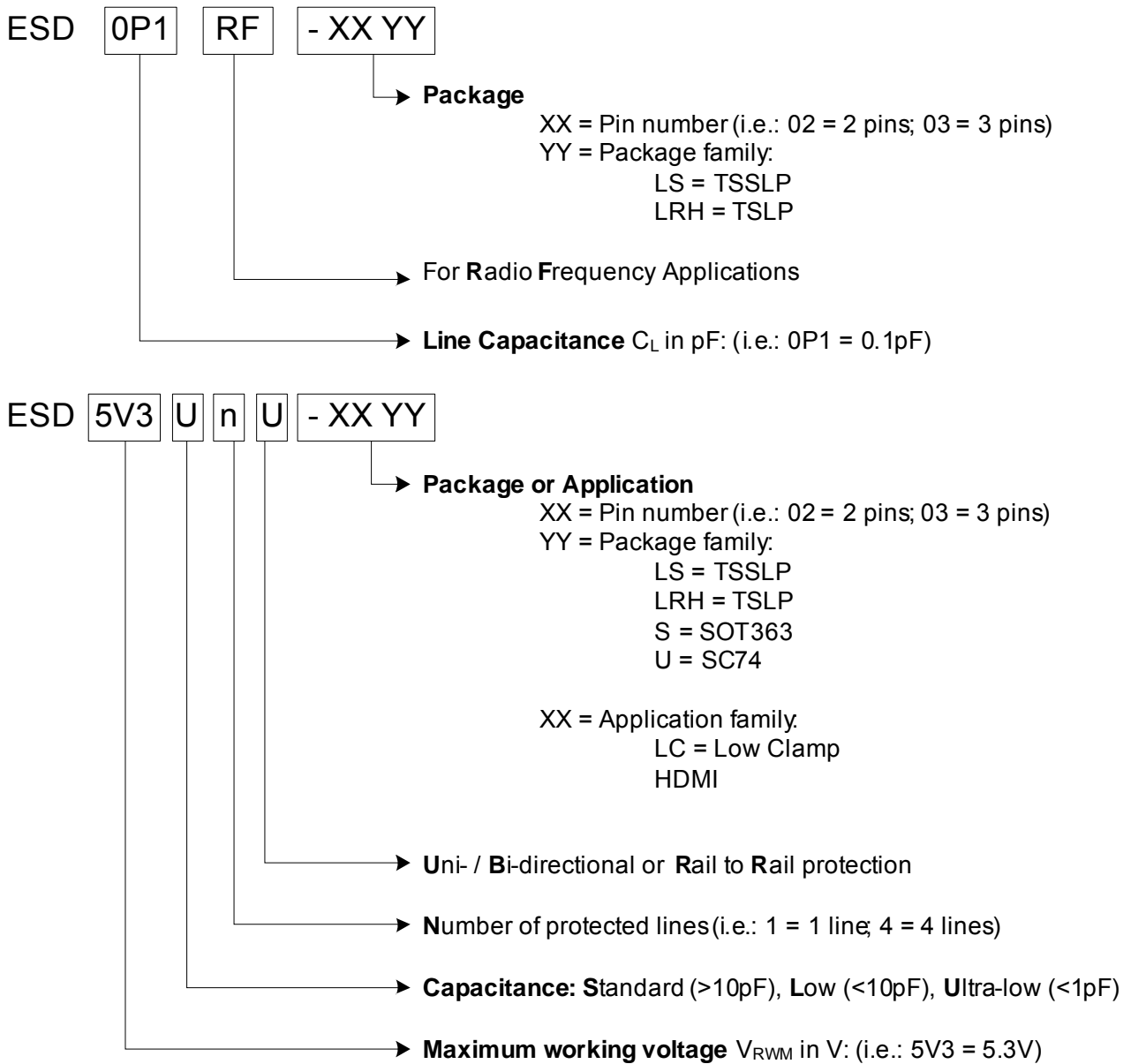

Figure 11 Ordering information scheme

## 5 Package Information

### 5.1 PG-TSLP-2-17 [2]

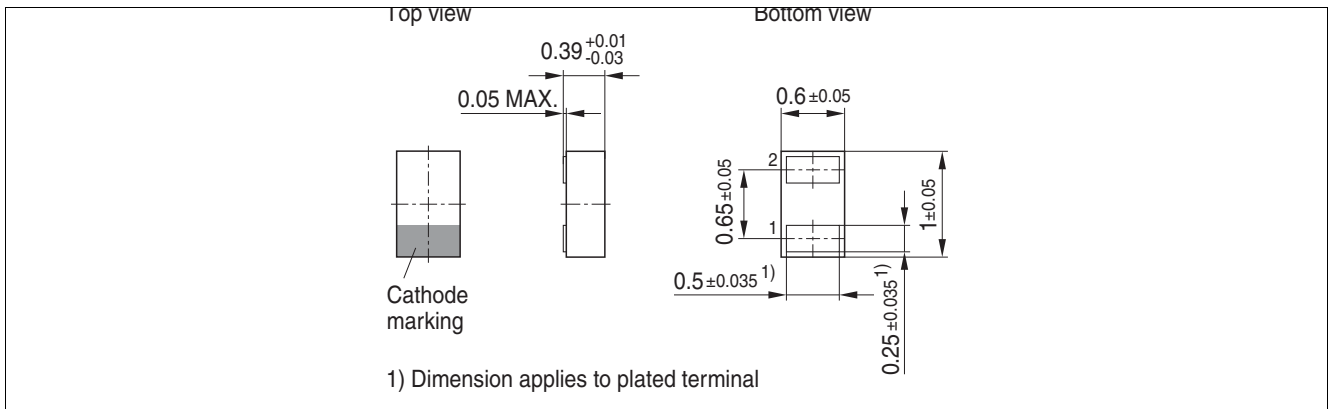

Figure 12 PG-TSLP-2-17: Package overview

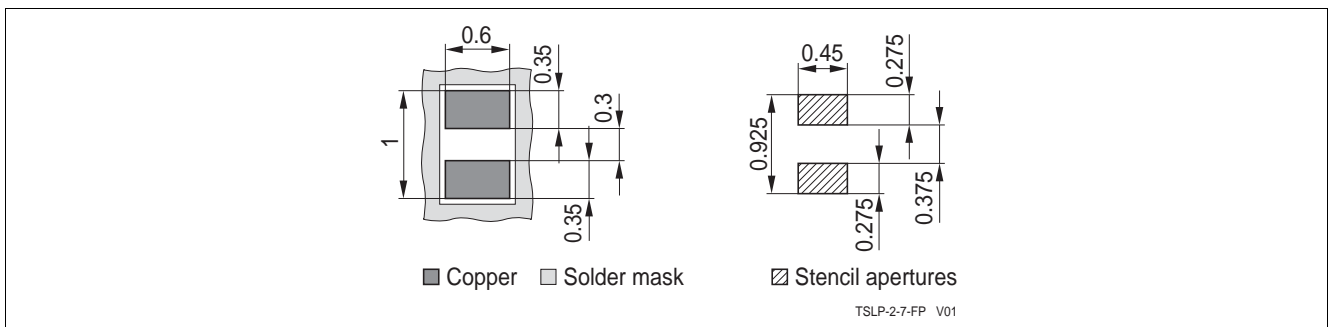

Figure 13 PG-TSLP-2-17: Footprint

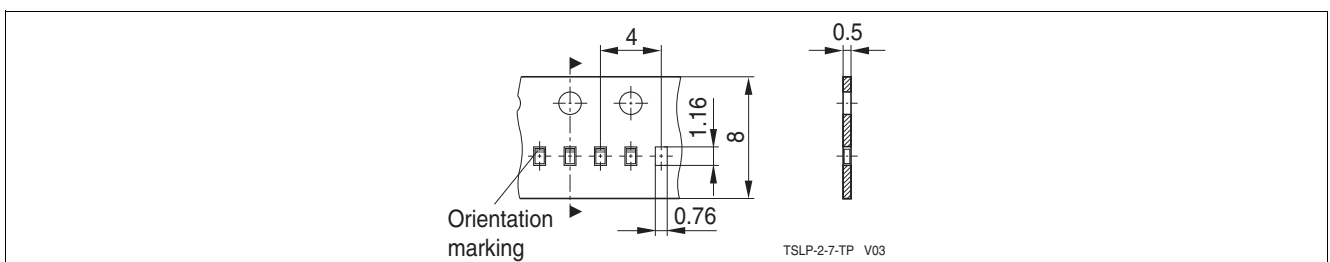

Figure 14 PG-TSLP-2-17: Packing

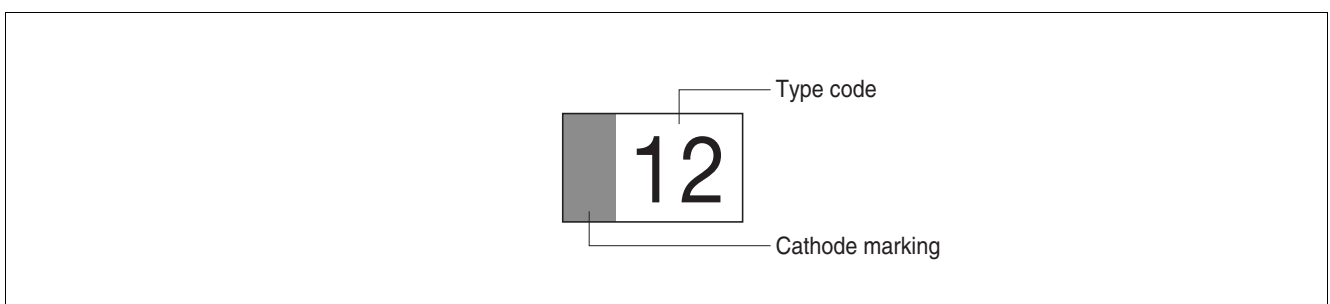

Figure 15 PG-TSLP-2-17: Marking (example)

**References**

- [1] Infineon AG - **Application Note AN210**: Effective ESD Protection design at System Level Using VF-TLP Characterization Methodology
- [2] Infineon AG - Recommendations for PCB Assembly of Infineon TSLP and TSSLP Packages
- [3] Infineon AG - **Application Note AN244**: Tailored ESD Protection for the NFC Frontend

[www.infineon.com](http://www.infineon.com)

Published by Infineon Technologies AG