

THIS DRAWING IS UNPUBLISHED. RELEASED FOR PUBLICATION
 © COPYRIGHT - By - ALL RIGHTS RESERVED.

REVISIONS					
P	LTR	DESCRIPTION	DATE	DWN	APVD
G		REVISED PER ECO-10-012870	27APR11	HMR	DR
G1		REVISED PER ECO-17-015223	17OCT2017	RS	DR

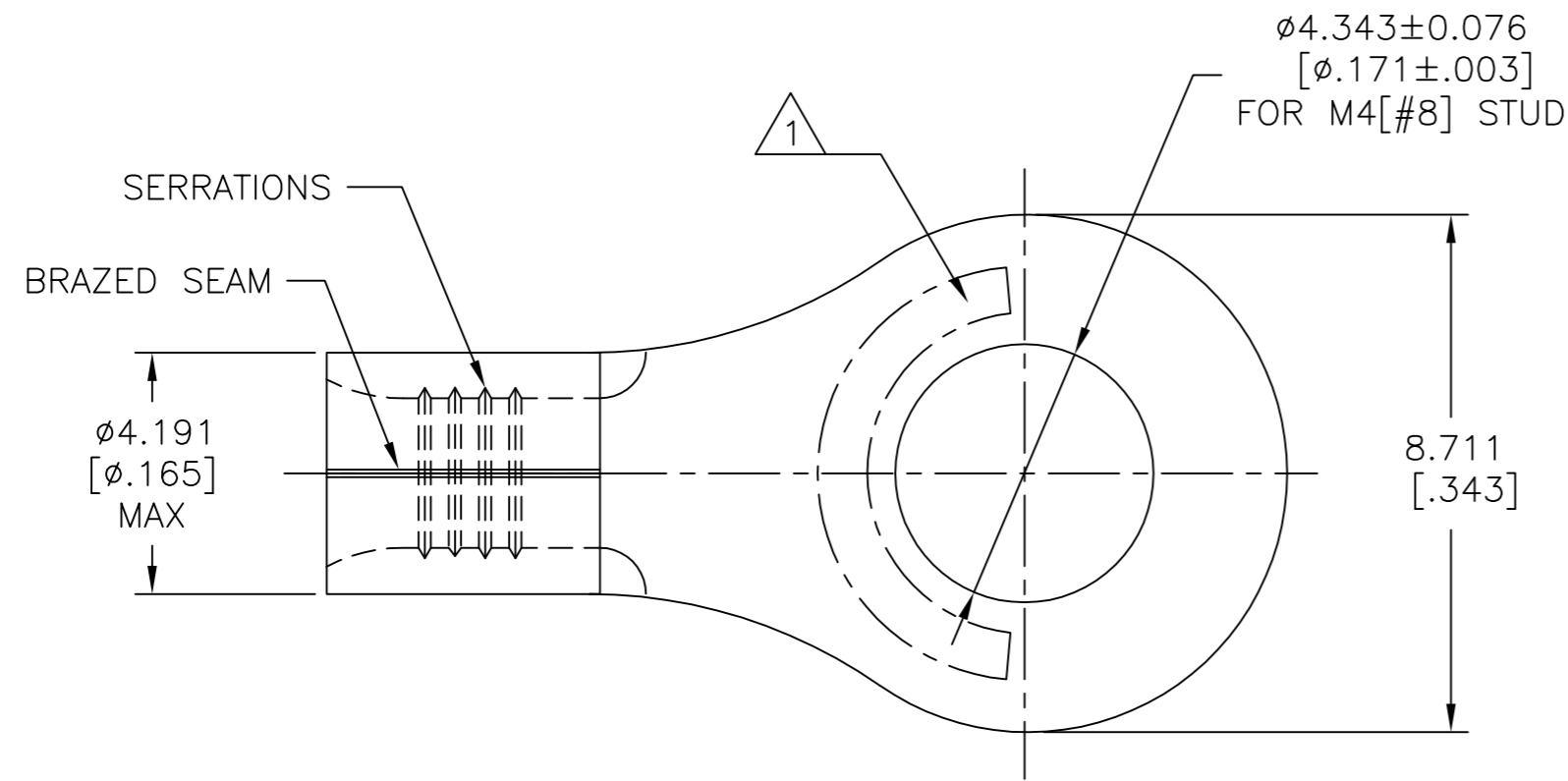

AMP
WIRE RANGE

16-14 AWG
SOLID OR STRANDED

- ① STAMP AMP 16-14* APPROX AS SHOWN
- ② COPPER PER ASTM B152, ANNEALED
- ③ NICKEL PLATE 0.00762(.000300)MIN EXT THK PER SAE AMS QQ-N-290
- ④ GOLD PLATE 0.00127(.000050)MIN EXT THK PER ASTM B488 TYPE 1, CODE C OVER NICKEL PLATE 0.00127[.000050] MIN EXT THK PER SAE AMS QQ-N-290 OVER Cu FLASH PER SAE AMS 2418.

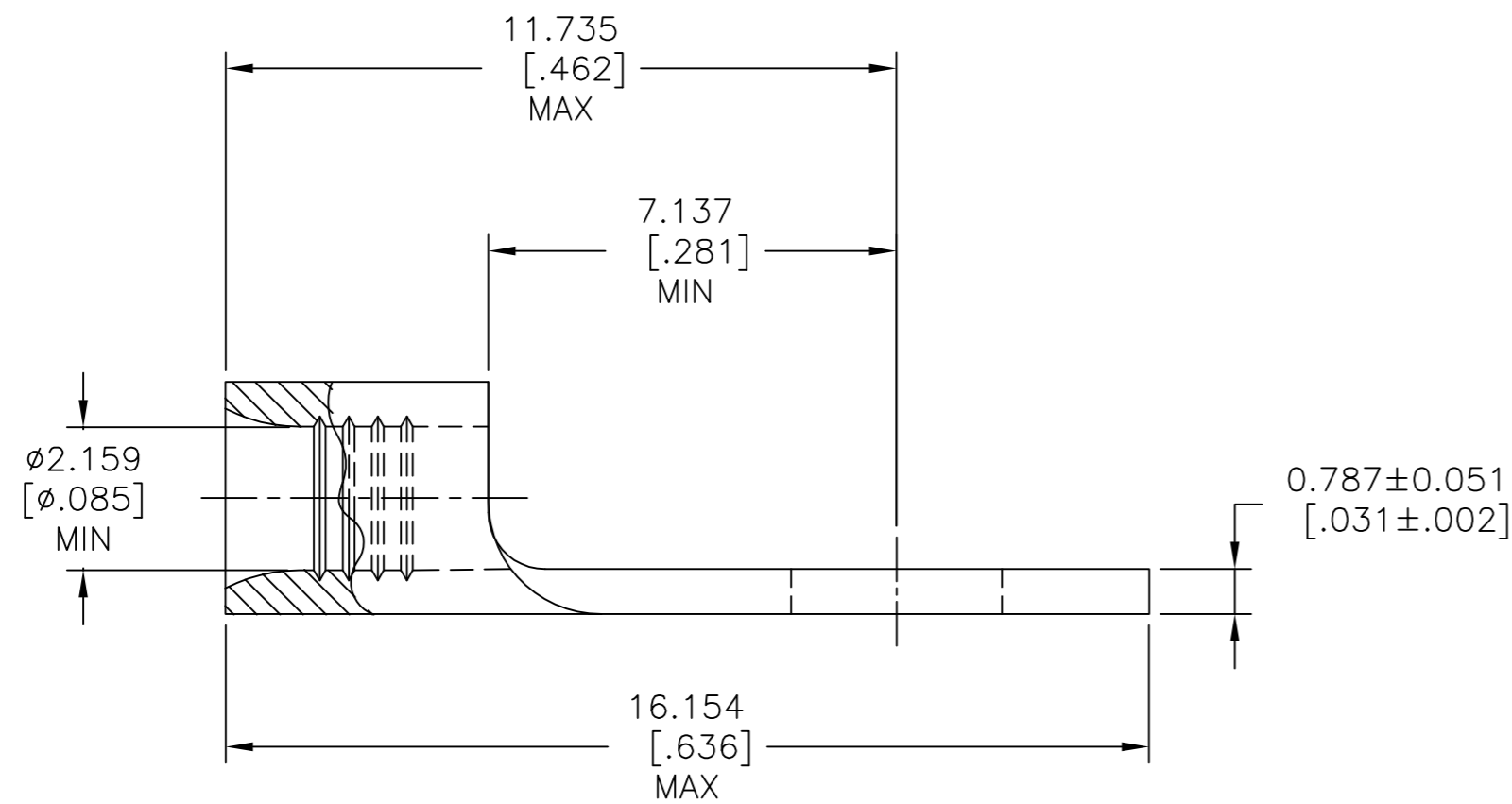

④	260°C[500°F]	1000	LOOSE PIECE	2-322694-3
③	343°C[649°F]	5000	322694 ON TAPE	2-322694-2
③	343°C[649°F]	1000	LOOSE PIECE	322694
	MAX TEMP	QTY	PACKAGE TYPE	PART NO

AMP INCORPORATED CUSTOMER SERVICE SYSTEMS		MAX RECOMMENDED OPERATING TEMPERATURE: SEE TABLE
FOR ADDITIONAL PRODUCT INFORMATION OR COPIES OF DRAWINGS AND TECHNICAL DOCUMENTS	PRODUCT INFORMATION CENTER 1-800-522-6752	VOLTAGE RATING: N/A
FOR APPLICATION TOOLING INFORMATION	TOOLING ASSISTANCE CENTER 1-800-722-1111	CIRCULAR MIL AREA: 1.04-2.62mm²[2,050-5,180] SOLID OR STRANDED
FOR ORDER ENTRY	1-800-526-5142	THIS DRAWING IS A CONTROLLED DOCUMENT FOR AMP INCORPORATED. IT IS SUBJECT TO CHANGE AND THE CONTROLLING ENGINEERING ORGANIZATION SHOULD BE CONTACTED FOR THE LATEST REVISION.

THIS DRAWING IS A CONTROLLED DOCUMENT.		DWN TA BRINKMAN 4-19-93	TE TE Connectivity	
DIMENSIONS: mm [INCHES]		CHK DA PATTERSON 4-19-93		
TOLERANCES UNLESS OTHERWISE SPECIFIED:		APVD DA PATTERSON 4-19-93	NAME DA PATTERSON	
0 PLC ± - 1 PLC ± - 2 PLC ± - 3 PLC ± 0.127[.005] 4 PLC ± - ANGLES ± -		PRODUCT SPEC	TERMINAL, RING TONGUE HEAT RESISTANT, STRATO-THERM, 16-14 AWG	
MATERIAL ②		FINISH SEE TABLE	SIZE A2	CAGE CODE 00779
		WEIGHT -	DRAWING NO C=322694	RESTRICTED TO -
		CUSTOMER DRAWING	SCALE 8:1	SHEET 1 of 1
			REV G1	