

WIRE COMBINATIONS FOR NYLON-INSUALTED CLOSED END CONNECTORS

MOLEX P/N: 191600002 (NC-1610), 191600128 (NC-1610 BULK)  
191600083 (NC-1610T), 191600156 (NC-1610BT)

UL LISTED & CSA CERTIFIED WIRE COMBINATIONS  
SOLID OR STRANDED, COPPER WIRE ONLY

12 AWG	14 AWG	16 AWG	18 AWG
1		1	
1			1
1			2
	1	1	
	1	2	
	1		1
	1		2
	1		3
	1	1	1
		1	1
		1	2
		1	3
		1	4
		2	1
		2	2
		2	3

12 AWG	14 AWG	16 AWG	18 AWG
		2	
		3	1
		3	
		5	3
			1
			4
	2		
	1	2	1
	1	3	
1	1		
		5	
		2	
	1		

ADDITIONAL UL LISTED WIRE COMBINATIONS

- (1) 18 AWG SOLID WITH (2) 18 AWG STRANDED
- (2) 18 AWG SOLID TWISTED OR UNTWISTED
- (2) 18 AWG STRANDED TWISTED OR UNTWISTED
- (1) 12 AWG SOLID WITH (1) 14 AWG STRANDED
- (1) 12 AWG SOLID WITH (1) 12 AWG STRANDED
- (1) 20 AWG STRANDED WITH (1) 18 AWG STRANDED
- (1) 20 AWG STRANDED WITH (2) 18 AWG STRANDED
- (2) 20 AWG STRANDED WITH (1) 18 AWG STRANDED
- (3) 20 AWG STRANDED
- (3) 20 AWG STRANDED WITH (1) 18 AWG STRANDED
- (4) 20 AWG STRANDED
- (1) 20 AWG STRANDED WITH (2) 14 AWG STRANDED
- (2) 12 AWG STRANDED
- (3) 14 AWG STRANDED
- (3) 14 AWG SOLID

NOTE: THIS DOCUMENT USED TO MAKE STUFFER SHEET  
PART NO: 194080109  
DOC NO'S: E-19160-009 & PK-19408-109

WIRE PREPARATION:

- NOTE: PRE-TWISTING NOT REQD FOR OEM APPLICATIONS  
SOLID: (OEM ONLY)  
A. STRIP LEADS TO .38(9.5)  
B. INSERT INTO CONNECTOR & CRIMP  
STRANDED:  
A. STRIP LEADS TO APROX. .75(19.1)  
B. TWIST WIRE COMBINATION EVENLY & TIGHT.  
C. TRIM STRIPPED PRE-TWISTED ZONE TO .38(9.5).  
D. INSERT INTO CONNECTOR AND CRIMP.

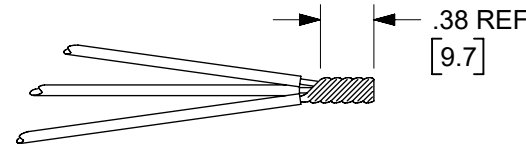

RATING 105°C 600 VOLT  
(1000 VOLT IN SIGNS OR FIXTURES)  
FILE: E32244



RATING 105°C 600 VOLT  
(1000 VOLT IN SIGNS OR FIXTURES)  
FILE: LR 18689  
\* 125°C FOR PRE-TWISTED WIRE ONLY

APPLICATION WITH HANDTOOL:

HOLD TOOL WITH LOCATOR PLATE FACING UP.  
INSERT CLOSED END CONNECTOR IN HOLE.  
INSURE THAT SHOULDER OF CONNECTOR IS RESTING  
ON LOCATOR PLATE.  
CLOSE TOOL JAWS UNTIL CONNECTOR IS HELD SNUG IN PLACE.  
LOAD CONNECTOR WITH DESIRED WIRE COMBINATION.  
COMPLETE CRIMP BY CLOSING TOOL HANDLES UNTIL  
THEY RELEASE.

CRIMP TOOLING AVAILABLE:

192880030 (ATP-301) AIR TAPE PRESS OR  
638858400 MINI-MAC TAPE APPLICATOR WITH  
192880236 (ATP-NC-1610) CRIMPING DIES OR  
NCEC CRIMP DIE-MARKED, "SIZE 16-10"

640010600 (RHT-7000) HANDTOOL  
640050600 (AT-7000) CRIMP HEAD OR 640053500 (AT-1610) CRIMP HEAD  
FOR 192790001 (AT-200) AIR HAND TOOL

FUNCTIONAL SYMBOLS FA = 0 FE = 0 FP = 0	THIS DRAWING CONTAINS INFORMATION THAT IS PROPRIETARY TO MOLEX ELECTRONIC TECHNOLOGIES, LLC AND SHOULD NOT BE USED WITHOUT WRITTEN PERMISSION		CURRENT REV DESC: P/N TYPO/ ERROR: 191600128 WAS 191620128 & 191600156 WAS 191620156. CRIMP TOOLING PN'S UPDATED.		<p>CLOSED END CONNECTOR WIRE COMBINATNS NC-1610 PRODUCT SPECIFICATION</p>
	DIMENSION UNITS	SCALE	GENERAL TOLERANCES (UNLESS SPECIFIED)		
	INCH/MM	NTS	MM	INCH	
	DIVISIONAL SYMBOLS		4 PLACES ±	3 PLACES ±	
1 PLACE ±		0 PLACES ±	ANGULAR TOL ± °		EC NO: 704038 DRWN: DMYRICK 2022/04/08 CHKD: JMACNEIL 2022/05/04 APPR: JMACNEIL 2022/05/04
DRAFT WHERE APPLICABLE MUST REMAIN WITHIN DIMENSIONS		THIRD ANGLE PROJECTION	DRAWING	SERIES	INITIAL REVISION: DRWN: JHACKNEY 1999/11/01 APPR: JMACNEIL 2012/06/06
DOCUMENT STATUS	P1	RELEASE DATE	2022/05/04	14:37:29	DOCUMENT NUMBER PS-19160-005
SEE CHART		CUSTOMER	GENERAL MARKET	SHEET NUMBER	1 OF 1

LOOSE PIECE		TAPE MOUNTED		"L" MAX.	"B" MIN (G1)	"D" MAX.	"E" MIN.	I.D. MIN.	O.D. MAX.	"A" DIM ±.02/0.5 (G1)
MATERIAL NO.	ENG. NO.	MATERIAL NO.	ENG. NO.							
191600012	NC-2214	191600070	NC-2214T	.62/15.7	.30/7.6	.19/4.8	.24/6.1	.09/2.3	.32/8.1	1.54/39.2
191600009	NC-2212	191600071	NC-2212T	.76/19.3	.30/7.6	.23/5.8	.27/6.9	.10/2.5	.36/9.1	1.63/41.4
191600002	NC-1610	191600083	NC-1610T	.90/22.8	.28/7.1	.28/7.1	.38/9.6	.15/3.8	.45/11.4	1.75/44.5
191600024	NC-8	191600028	NC-8T	1.10/27.9	.42/10.6	.36/9.1	.48/12.2	.21/5.3	.57/14.5	1.86/47.4

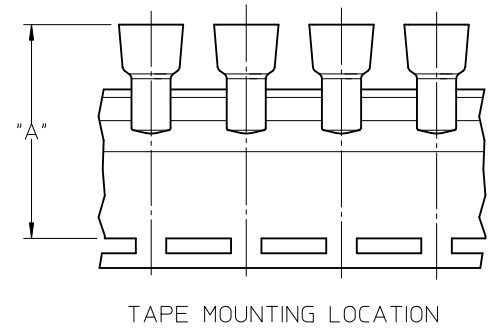
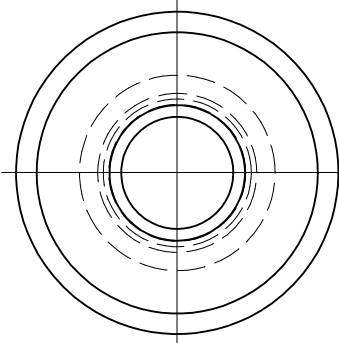
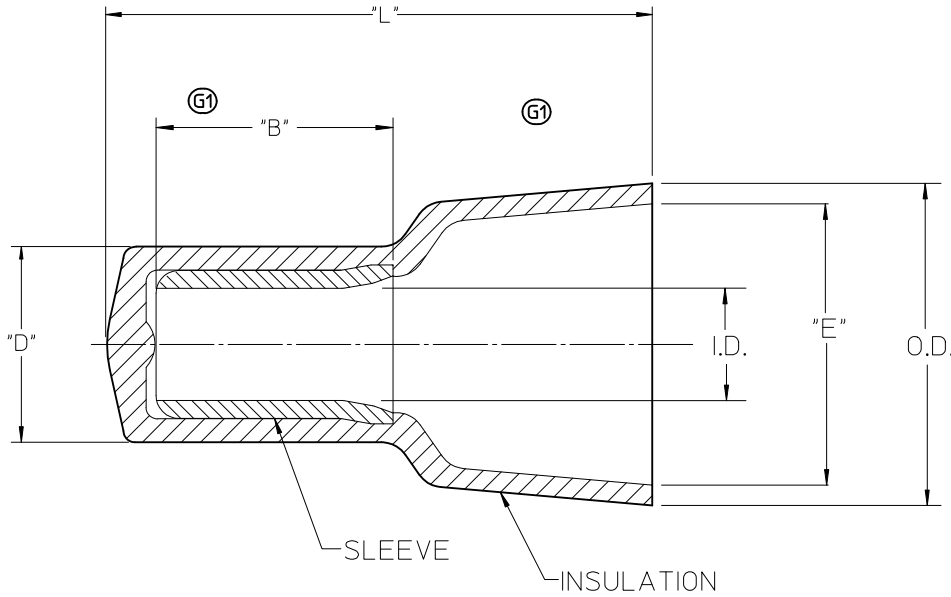

NOTES:

- MATERIAL: SLEEVE: TIN-PLATED COPPER  
INSULATION: 6/6 NYLON,  
NATURAL TRANSLUCENT
- PARTS ARE ROHS COMPLIANT.

SALES DRAWING

<b>CORRECT TOLERANCES</b> EC NO: WNA2010-0673 DRAWN BY: DR. W. H. THRODAHL 2010/05/07 CHK'D BY: R. DEROSS 04/02/23 APPR: JMACEIL 2010/06/23	QUALITY SYMBOLS ▽=0 ▽=0	GENERAL TOLERANCES (UNLESS SPECIFIED)		DIMENSION STYLE		SCALE	DESIGN UNITS	THIRD ANGLE PROJECTION			
				IN/MM		5:1	INCH				
				DRAWN BY DATE		CHECKED BY DATE		CLOSED END CONNECTORS NYLON INSULATED <b>MOLEX INCORPORATED</b>			
				H. BEITZE 04/02/23		R. DEROSS 04/02/23					
		APPROVED BY DATE		MATERIAL NO.		DOCUMENT NO.		SHEET NO.			
		R. DEROSS 04/02/23		SEE CHART		SD-19160-001		1 OF 1			
		DRAFT WHERE APPLICABLE MUST REMAIN WITHIN DIMENSIONS		SIZE B		THIS DRAWING CONTAINS INFORMATION THAT IS PROPRIETARY TO MOLEX INCORPORATED AND SHOULD NOT BE USED WITHOUT WRITTEN PERMISSION					