

May.1.2023 Copyright 2023 HIROSE ELECTRIC CO., LTD. All Rights Reserved.
In case of consideration for using Automotive equipment / device which demand high reliability, kindly contact our sales window correspondents.

Attachment: Unified screw thread 0-80UNF 1/4inch

MARKING POSITION

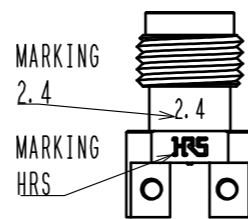

- NOTES
- 1 WHEN MATING THE CONNECTOR, PLEASE HOLD MILLING AREA OF 6.4 ± 0.2 WITH A WRENCH.
 - 2 0-80UNF-2B SCREW TIGHTENING TORQUE IS $0.09 \text{ N} \cdot \text{m}$. PLEASE TIGHTEN THE SCREWS EVENLY WHEN MOUNTING THE CONNECTORS TO ENSURE STABLE ELECTRICAL CONTACT.
 - 3 PLEASE USE A PCB MOUNTING SCREW OF THE LENGTH OF L(mm). THE LENGTH OF L(mm) IS PCB THICKNESS $t_1(\text{mm})$ + SPRING WASHER THICKNESS $t_2(\text{mm})$ + $1.8(\text{mm})$. PLEASE USE A SCREW WITH SPRING WASHER.
 - 4 THE INDICATED DIMENSION IS THE CASE OF WHICH DIELECTRIC CONSTANT OF SUBSTRATE IS 3.35 AND THICKNESS IS $t=0.2\text{mm}$. LAND PATTERN LAYOUT DEPENDS ALSO ON ELECTRIC CONSTANT, THICKNESS AND LAYER CONSTRUCTION OF PCB. FOR BETTER PERFORMANCE, SIMULATION OF PCB WITH CONNECTOR IS RECOMMENDED.
 - 5 RECOMMENDED PCB THICKNESS t_1 IS GREATER THAN 1.0mm .
 - 6 SIDE PLATING OF THE BOARD IS RECOMMENDED.
 - 7 THIS CONNECTOR SHOULD BE USE FOR TEST PORT ONLY.

MOUNTING OF CONNECTOR

- (1) WHEN THE CONNECTOR IS MOUNTED ON PCB, PLEASE DO NOT ALLOW A GAP BETWEEN THE EDGE OF PCB AND CONNECTOR.
- (2) PLEASE MOUNT THE CONNECTOR AS LOCATED IN THE MIDDLE OF THE SIGNAL PAD OF PCB.
- (3) SOLDERING CONDITIONS:(OPTIONAL:IT'S POSSIBLE TO USE WITHOUT SOLDERING)
FOR THE MANUAL SOLDERING, SOLDERING IRON BIT TEMPERATURE IS 380°C MAX. FOR 5 SECONDS MAX.

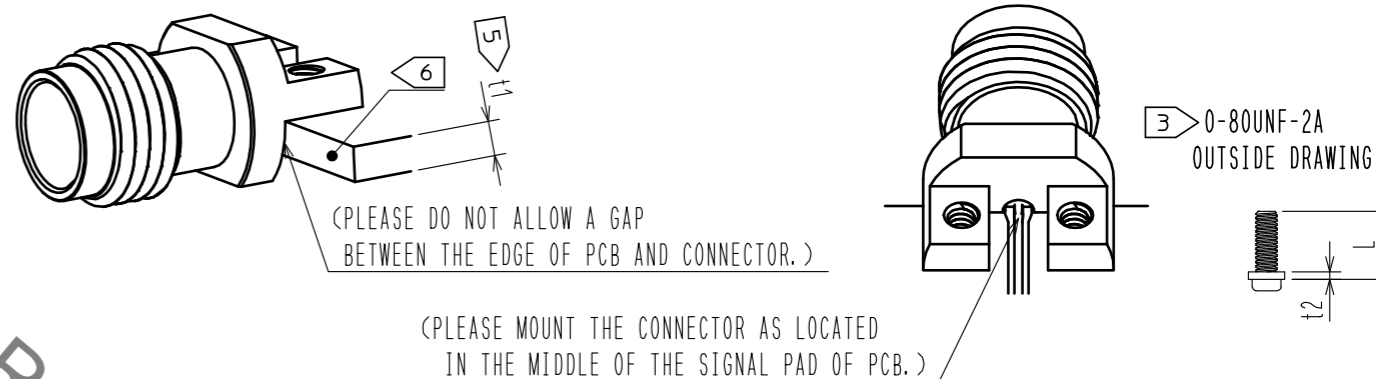

RECOMMENDED PC BOARD PATTERN DRAWING

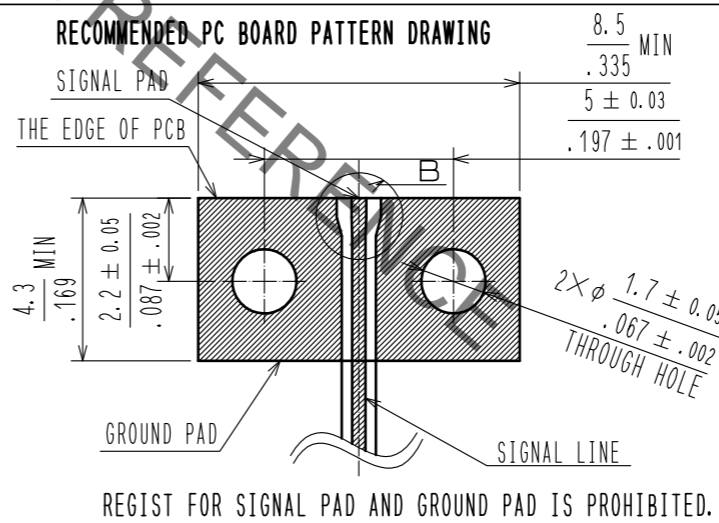

(DRAWING CHANGED)
B(10:1)

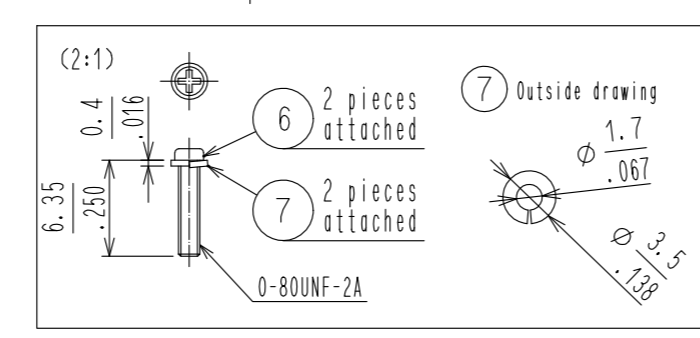
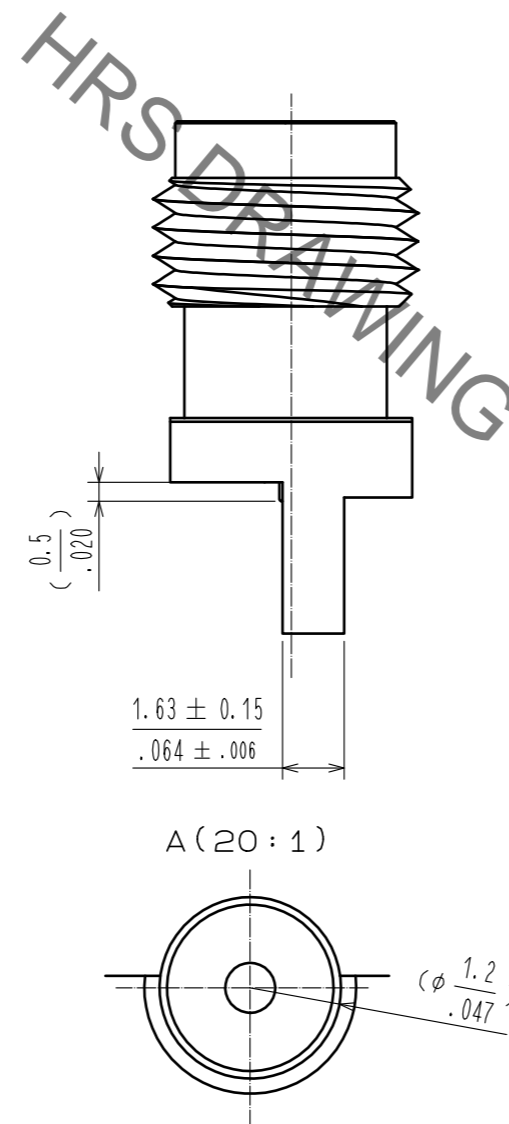
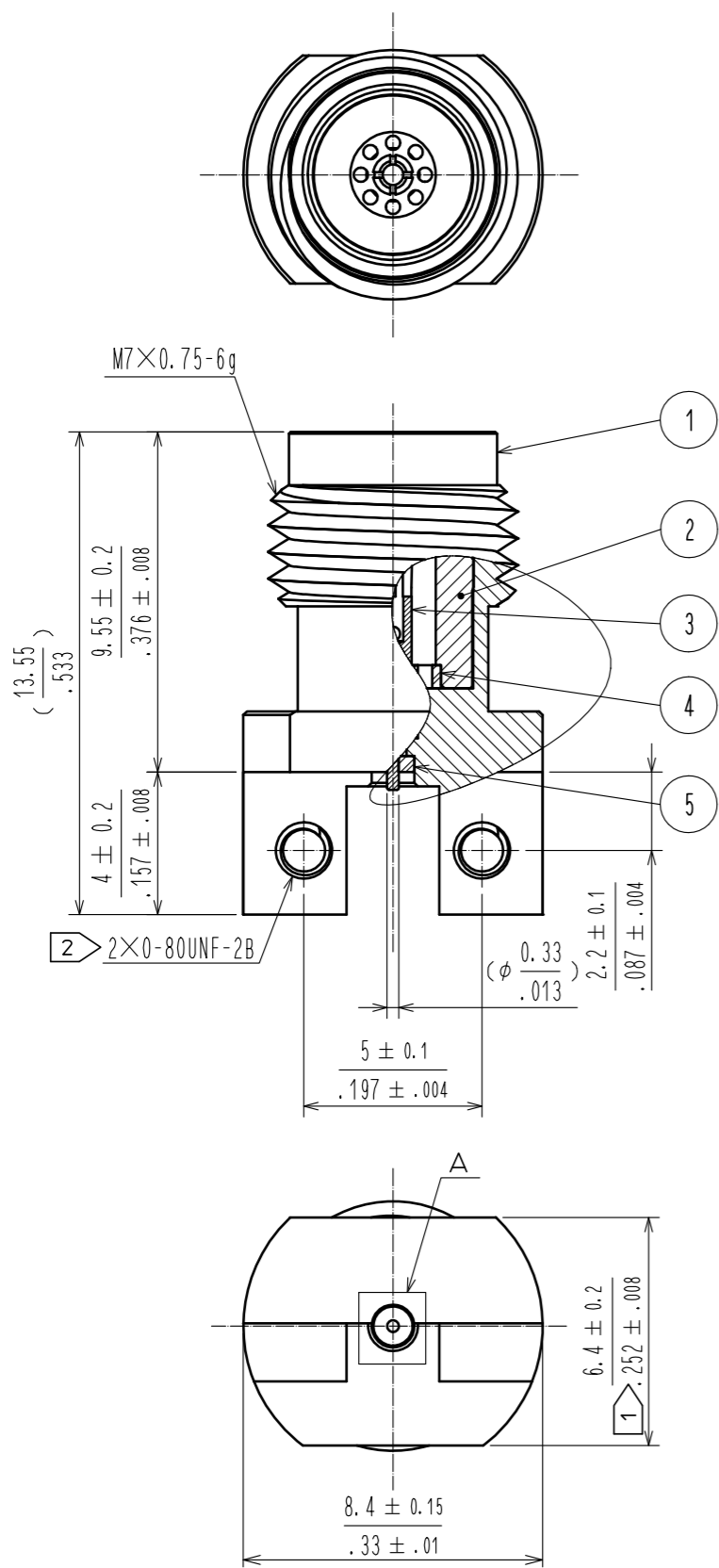
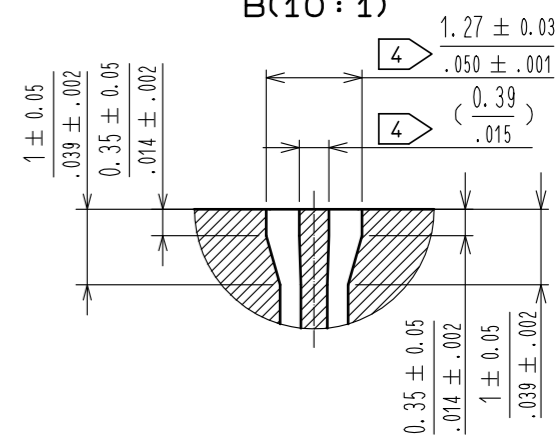

3	BERYLLIUM COPPER	GOLD PLATING	7	STAINLESS STEEL	Spring washer
2	STAINLESS STEEL	PASSIVATE	6	STEEL	0-80UNF-2A Screw
1	BRASS	NICKEL PLATING	5	POLYETHER IMIDE	
			4	POLYETHER IMIDE	

NO.	MATERIAL	FINISH	REMARKS	NO.	MATERIAL	FINISH	REMARKS
UNITS [mm/in]		SCALE 5:1	COUNT 1	DESCRIPTION OF REVISIONS	DESIGNED DS. YAMAKOSHI	CHECKED NK. NINOMIYA	DATE 18.06.19
APPROVED: KH. IKEDA 17.01.23				DRAWING NO. EDC-368795-11-01			
CHECKED: TS. NOBE 17.01.20				PART NO. H2.4-LR-SR2(11)			
DESIGNED: TP. MATSUMOTO 17.01.20				CODE NO. CL338-0603-0-11			
DRAWN: TP. MATSUMOTO 17.01.20				1/1			