

Apr.1.2023 Copyright 2023 HIROSE ELECTRIC CO., LTD. All Rights Reserved.
In case of consideration for using Automotive equipment / device which demand high reliability, kindly contact our sales window correspondents.

COUNT	DESCRIPTION OF REVISIONS	BY	CHKD	DATE	COUNT	DESCRIPTION OF REVISIONS	BY	CHKD	DATE
△				..	△				..
△				..	△				..
△				..	△				..

RECOMMENDED LAND PATTERN DIMENSION OF PCB (MOUNTING SIDE)

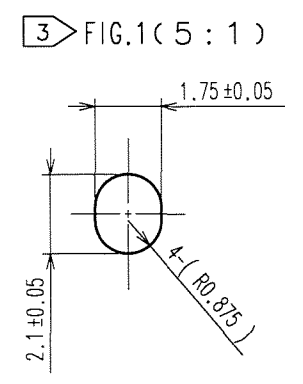
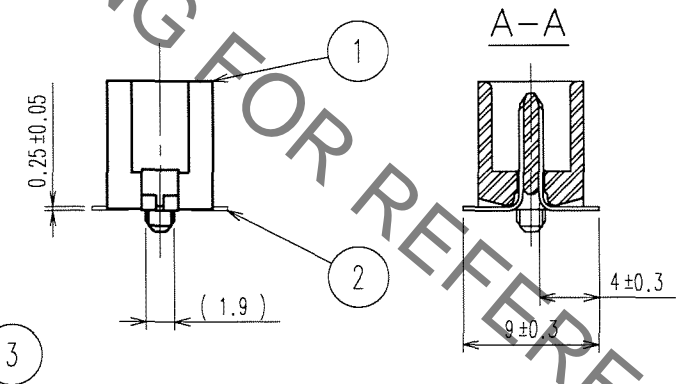
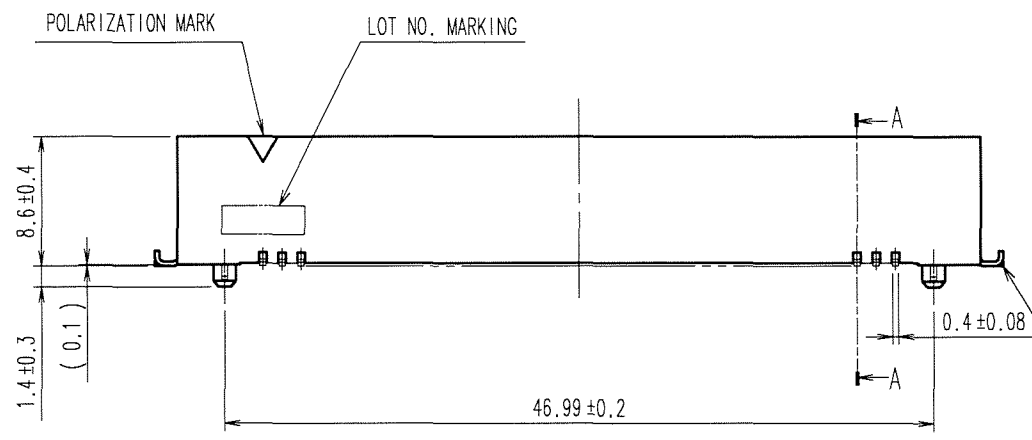
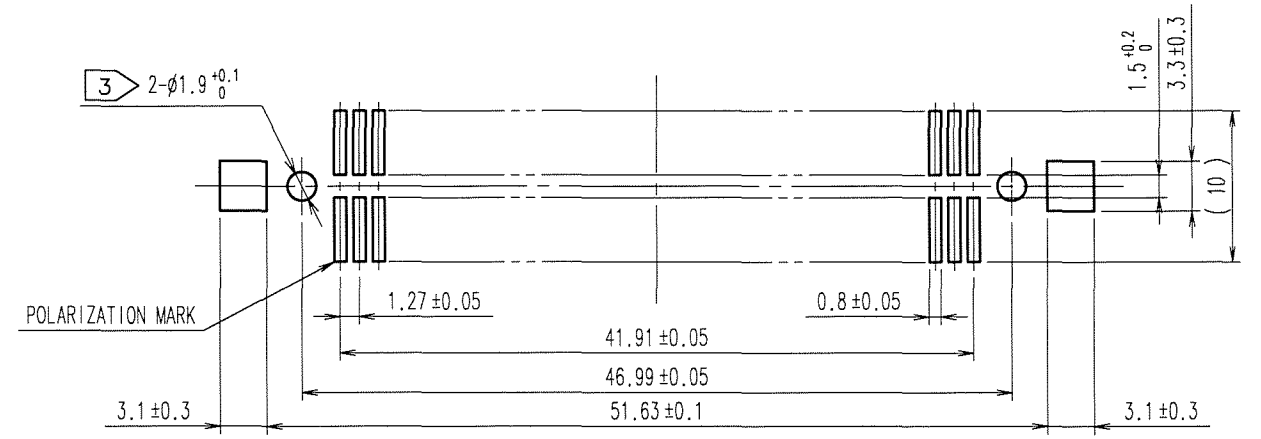
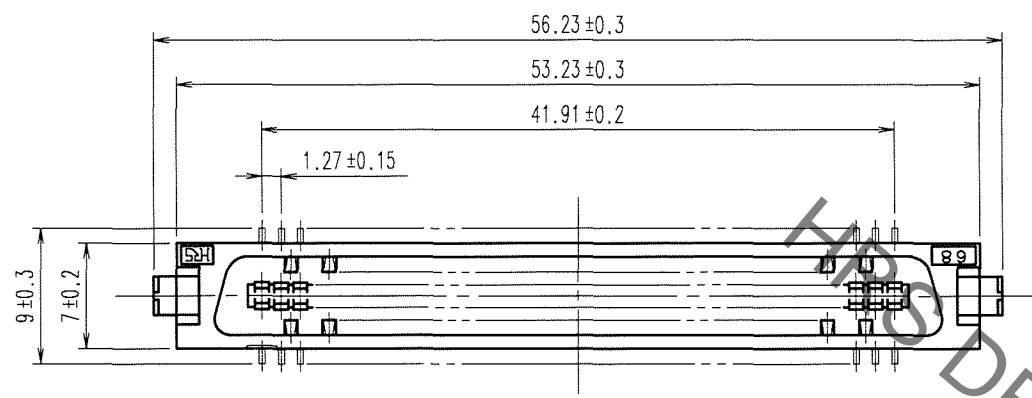

- NOTES
- 1 LEAD CO-PLANARITY SHALL BE 0.15 MAX.
 - 2 THE DIMENSIONS IN PARENTHESES ARE FOR REFERENCE.
 - 3 IN CASE OF THE AUTOMATED MOUNTING, RECOMMENDED HOLE DIAMETER OF BOSS IS SHOWN IN FIG.1.

3	BRASS	TIN-PLATING	2	PHOSPHOR BRONZE	CONTACT AREA:GOLD 0.2μ m min.
1	PPS	LIGHT BROWN (UL94V-0)			LEAD AREA:TIN-PLATING 2μ m min.
					UNDER PLATING:NICKEL 2μ m min.
NO.	MATERIAL	FINISH, REMARKS	NO.	MATERIAL	FINISH, REMARKS
CODE NO. (OLD) CL			DRAWN	DESIGNED	CHECKED
			A.SUZUKAWA	<i>K. Nakamura</i>	<i>K. Ogawa</i>
			06.03.07	06.03.07	06.03.07
				APPROVED	RELEASED
				<i>H. Okawa</i>	..
DRAWING NO. EDC3-082407-21			PART NO. FX2-68P-1.27SVL (71)		
SCALE 2 : 1			CODE NO. CL572-2056-0-71		
UNITS mm			1/1		

TO
PCK