

E43002

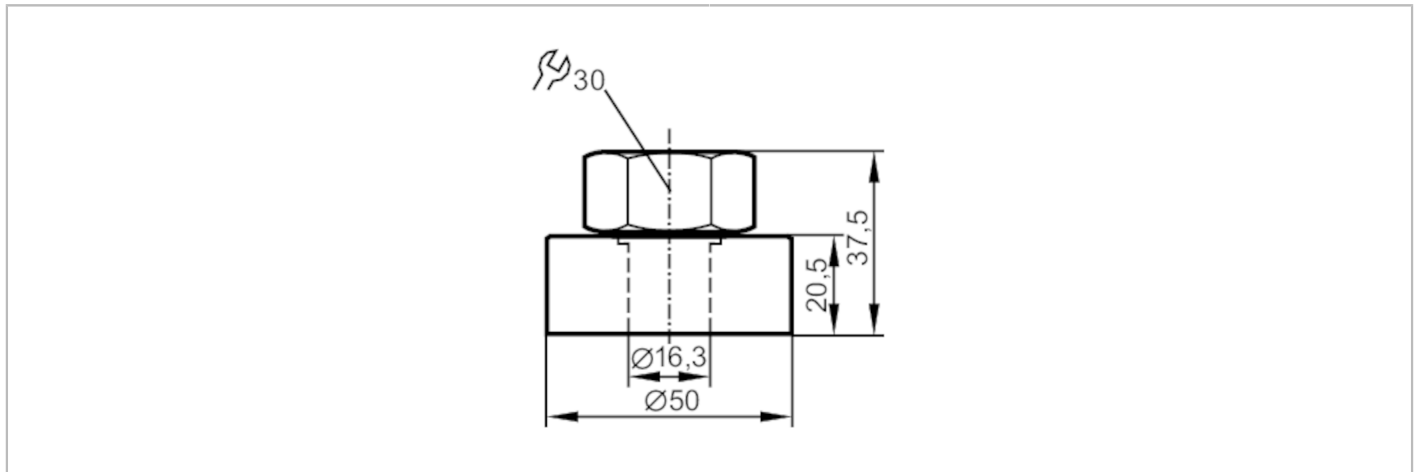

Welding adapter for level sensors

WELDING ADAPTER 50/D16



Application	
Design	for capacitive level sensors LK, LI, LT, LL
Installation	Clamp fitting
Pressure rating [bar]	0.5
Operating conditions	
Ambient temperature [°C]	0...80
Tests / approvals	
Pressure Equipment Directive	A possible classification to PED depends on the application and has to be carried out by the user / operator.
Pressure Equipment Directive EAC	The adapter is intended for use in devices, machines and installations that do not fall under the categories of the technical rule TR CU 032/2013.
Safety instructions	The compatibility between medium and product material has to be checked in all applications.
Mechanical data	
Weight [g]	394.5
Dimensions [mm]	Ø 50 / L = 37.5
Materials	flange: stainless steel; Lock nut: stainless steel; spacer: brass; clamping ring: FKM
Tightening torque [Nm]	6...9
Sensor connection	Ø 16 mm
Process connection	welding adapter Ø 50 mm
Remarks	
Pack quantity	1 pcs.