

May.1.2023 Copyright 2023 HIROSE ELECTRIC CO., LTD. All Rights Reserved.
In case of consideration for using Automotive equipment / device which demand high reliability, kindly contact our sales window correspondents.

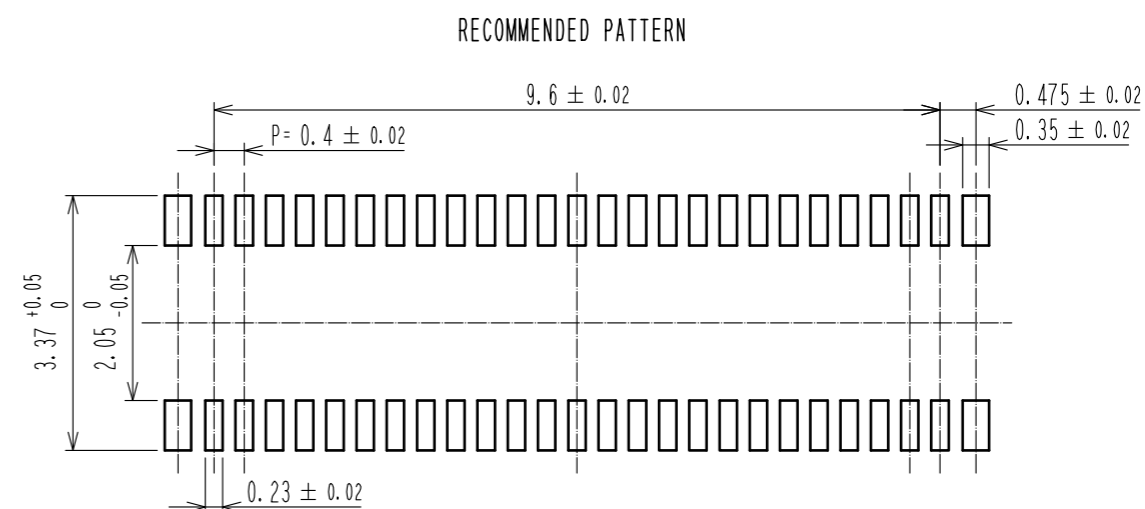

RECOMMENDED METAL MASK THICKNESS: 120 μm
RECOMMENDED METAL MASK OPENING RATIO: 80% FOR LEAD PAD

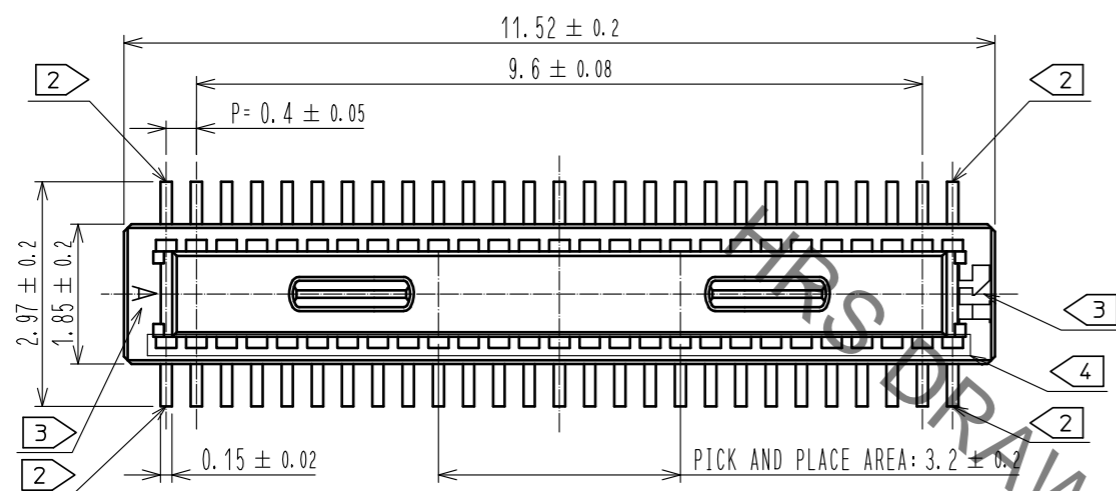
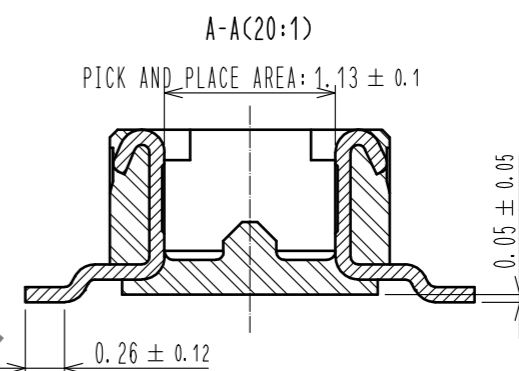
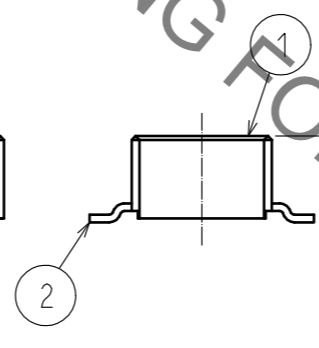
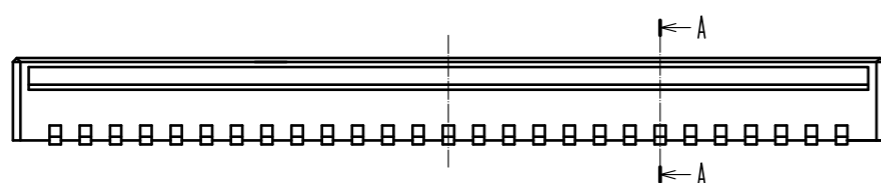

- NOTES)
1. ALL LEADS CO-PLANARITY SHALL BE 0.1mm MAX.
 2. EACH ONE CONTACT AT 4 CORNERS SHALL BE METAL HOLD DOWN.
 3. HRS MARK AND CAV NO. IS INDICATED IN APPROXI POSITION SHOWN.
 4. THERE IS A POSSIBILITY THAT THE RESIN WILL BE EXPOSED AT THIS AREA. BUT THIS WILL NOT AFFECT THE CONTACT RELIABILITY.

2	COPPER ALLOY	CONTACT AREA: GOLD 0.05 μm MIN	6	PS	CLEAR, REINFORCEMENT COLLAR			
		SMT LEAD: GOLD 0.05 μm MIN	5	PS	BLACK			
		UNDERPLATING: NICKEL 1 μm MIN	4	POLYESTER	CLEAR, COVER TAPE			
1	LCP	BLACK, UL94V-0	3	PS	CLEAR, EMBOSSED CARRIER TAPE			
NO.	MATERIAL	FINISH . REMARKS	NO.	MATERIAL	FINISH . REMARKS			
UNITS mm		SCALE 10: 1	COUNT 	DESCRIPTION OF REVISIONS		DESIGNED	CHECKED	DATE
HRS HIROSE ELECTRIC CO., LTD.		APPROVED : WR. FUKUCHI	20210303	DRAWING NO.		EDC-386792-58-00		
		CHECED : TS. MIYAZAKI	20210303	PART NO.		DF40TC-50DP-0.4V(58)		
		DESIGNED : YK. SATAKE	20210303	CODE NO.		CL0684-4268-0-58		
		DRAWN : YK. SATAKE	20210303			1/2		

May.1.2023 Copyright 2023 HIROSE ELECTRIC CO., LTD. All Rights Reserved.
 In case of consideration for using Automotive equipment / device which demand high reliability, kindly contact our sales window correspondents.

EMBOSSED CARRIER TAPE PACKAGING(5:1)

STYLE AND DIMENSIONS OF REEL(FREE)

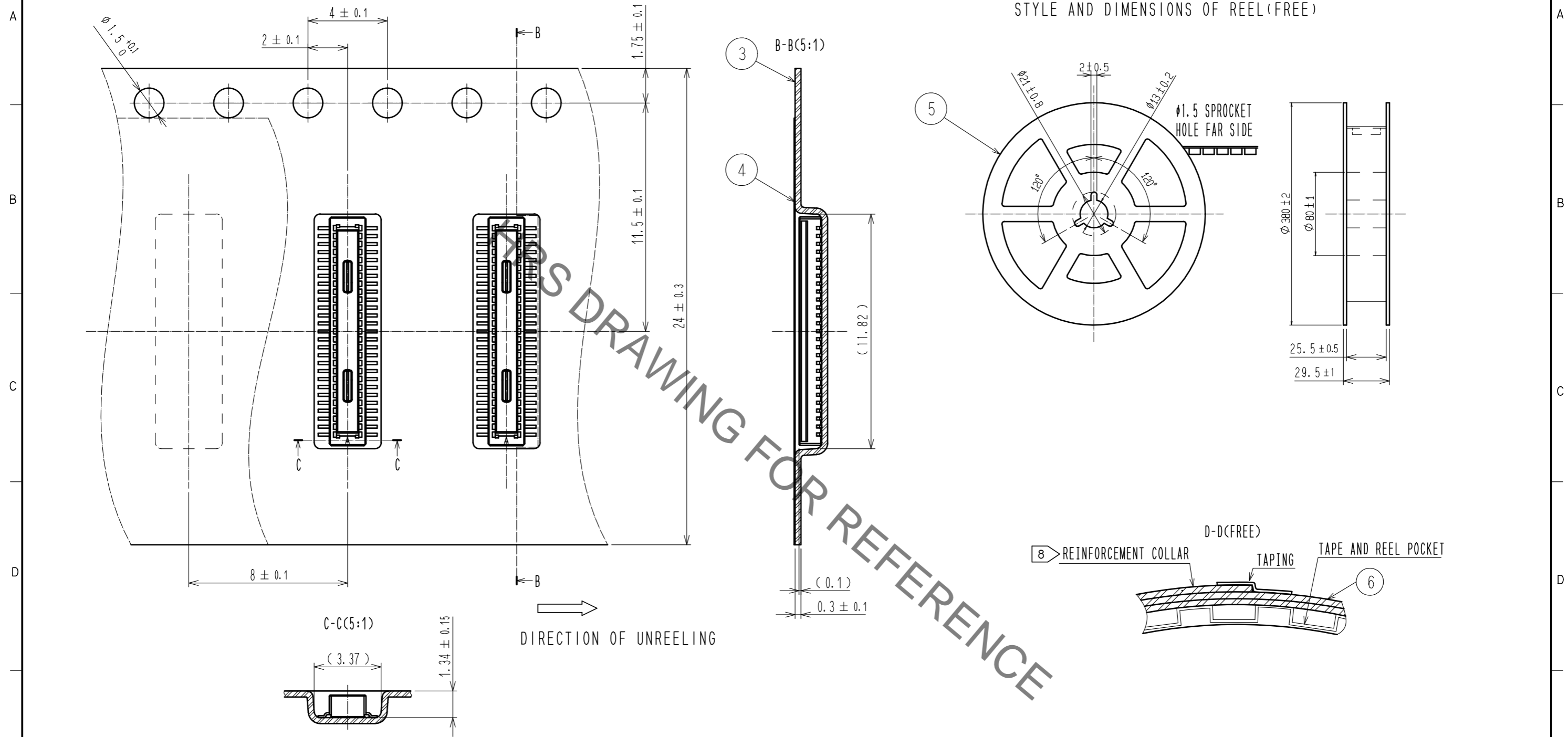

DIRECTION OF UNREELING

PORTION EQUIPPED WITH CONNECTORS(FREE)

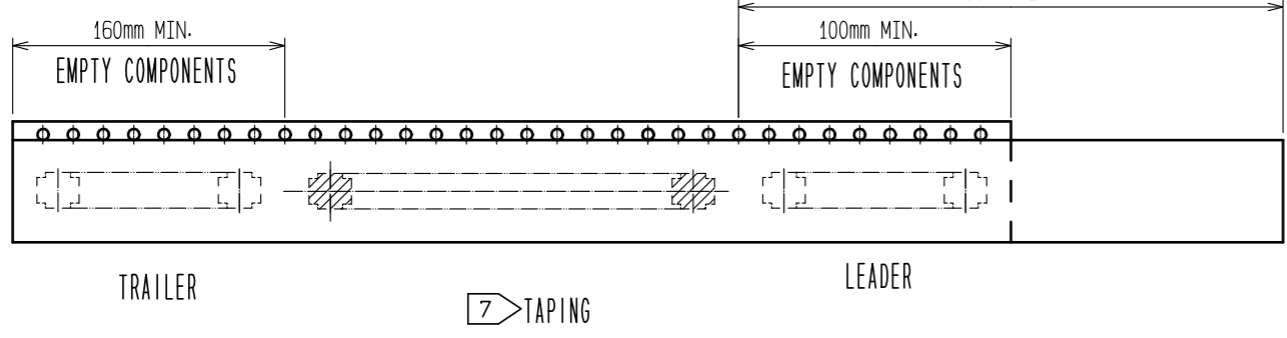

- NOTES
- 5. PER REEL 1000 CONNECTORS.
 - 6. THE DIMENSIONS IN PARENTHESES ARE FOR REFERENCE.
 - 7. REFER TO JIS C 0806. IEC-60286 (PACKING OF COMPONENTS FOR AUTOMATIC HANDLING)
 - 8. AFTER PACKAGING. ROLL 2 METERS OF THE REINFORCEMENT COLLAR TO OUTER CIRCUMFERENCE OF TAPE AND REEL POCKET. AND TAPE DOWN AT THE END THE COLLAR.

HRS	DRAWING NO.	EDC-386792-58-00
	PART NO.	DF40TC-50DP-0.4V(58)
	CODE NO.	CL0684-4268-0-58
		2/2