

THIS DRAWING IS UNPUBLISHED. RELEASED FOR PUBLICATION
 © COPYRIGHT - By - ALL RIGHTS RESERVED.

REVISIONS					
P	LTR	DESCRIPTION	DATE	DWN	APVD
F1		REVISED PER ECO-11-004917	11MAR11	RK	HMR
F2		REVISED PER ECO-17-008808	03MAR2018	RS	DR

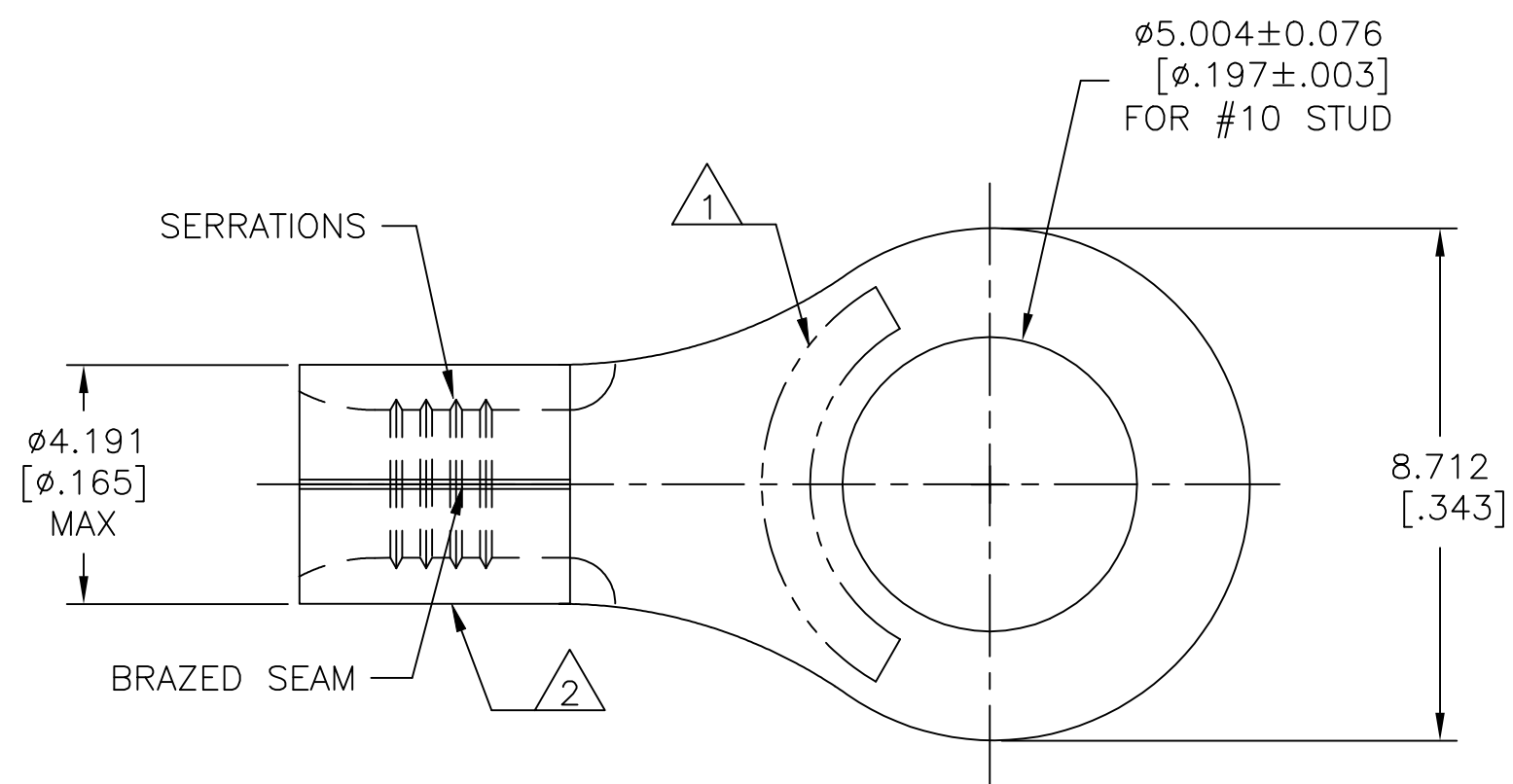

AMP WIRE RANGE	E13288 Listed
16-14 AWG SOLID OR STRANDED	NOT APPLICABLE
LR7189 Certified	MILITARY P/N AND CLASS
NOT APPLICABLE	NOT APPLICABLE

- STAMP AMP 16-14 APPROX AS SHOWN
- WIRE BARREL COLOR CODED ORANGE TO DENOTE NICKEL MATERIAL

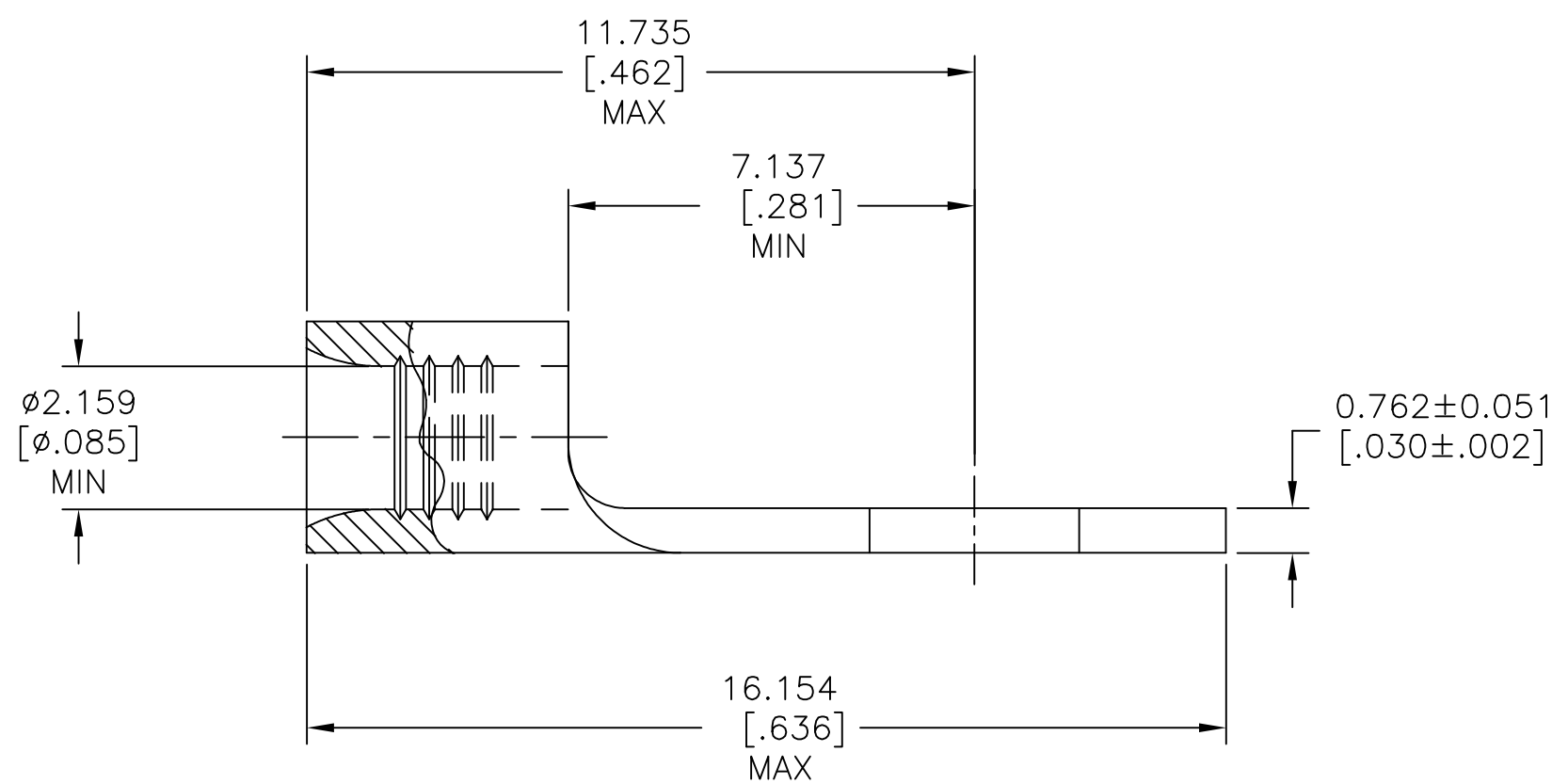

**AMP INCORPORATED
CUSTOMER SERVICE SYSTEMS**

MAX RECOMMENDED OPERATING TEMPERATURE:
649°C [1200°F] MAX

FOR ADDITIONAL PRODUCT INFORMATION OR COPIES OF DRAWINGS AND TECHNICAL DOCUMENTS

PRODUCT INFORMATION CENTER
1-800-522-6752

VOLTAGE RATING:
NOT APPLICABLE

FOR APPLICATION TOOLING INFORMATION

TOOLING ASSISTANCE CENTER
1-800-722-1111

WIRE CROSS SECTIONAL AREA RANGE:
1.04-2.62mm² [2,050-5,180] CIR MILS
SOLID OR STRANDED

FOR ORDER ENTRY

1-800-526-5142

THIS DRAWING IS A CONTROLLED DOCUMENT FOR AMP INCORPORATED. IT IS SUBJECT TO CHANGE AND THE CONTROLLING ENGINEERING ORGANIZATION SHOULD BE CONTACTED FOR THE LATEST REVISION.

100	LOOSE PIECE, BOX	8-322335-1
5000	ON TAPE	2-322335-5
1000	LOOSE PIECE	322335
QTY	PACKAGING TYPE	PART NO

THIS DRAWING IS A CONTROLLED DOCUMENT.		DWN TA BRINKMAN 4-15-93	TE Connectivity Ltd.		
DIMENSIONS: mm [INCHES]		CHK DA PATTERSON 4-15-93			
TOLERANCES UNLESS OTHERWISE SPECIFIED:		APVD DE MILLER 4-15-93	NAME TERMINAL, RING TONGUE, HIGH TEMPERATURE, STRATO-THERM™ 16-14 AWG		
0 PLC ± - 1 PLC ± - 2 PLC ± - 3 PLC ± 0.127[.005] 4 PLC ± - ANGLES ± -		PRODUCT SPEC APPLICATION SPEC	SIZE A2	CAGE CODE 00779	DRAWING NO C=322335
MATERIAL NICKEL PER ASTM B-162 ANNEALED		FINISH -	WEIGHT	RESTRICTED TO -	SCALE 8:1
CUSTOMER DRAWING			SHEET 1 of 1	REV F2	