

May.1.2023 Copyright 2023 HIROSE ELECTRIC CO., LTD. All Rights Reserved.  
In case of consideration for using Automotive equipment / device which demand high reliability, kindly contact our sales window correspondents.

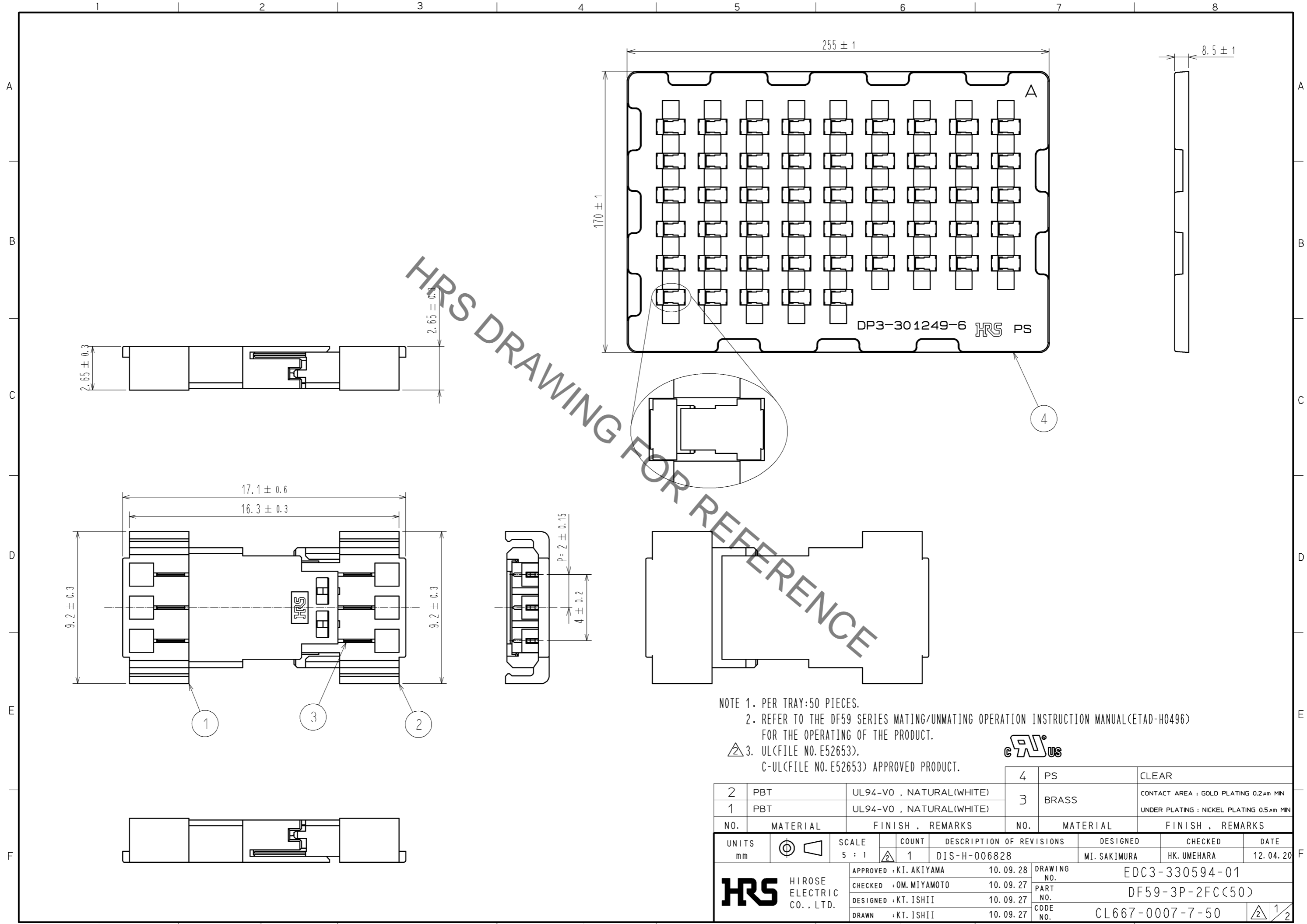

NOTE 1. PER TRAY:50 PIECES.  
 2. REFER TO THE DF59 SERIES MATING/UNMATING OPERATION INSTRUCTION MANUAL(ETAD-H0496) FOR THE OPERATING OF THE PRODUCT.  
 3. UL(FILE NO. E52653),  
 C-UL(FILE NO. E52653) APPROVED PRODUCT.



NO.	MATERIAL	FINISH . REMARKS	NO.	MATERIAL	FINISH . REMARKS
2	PBT	UL94-V0 , NATURAL(WHITE)	4	PS	CLEAR
1	PBT	UL94-V0 , NATURAL(WHITE)	3	BRASS	CONTACT AREA : GOLD PLATING 0.2µm MIN UNDER PLATING : NICKEL PLATING 0.5µm MIN

UNITS	SCALE	COUNT	DESCRIPTION OF REVISIONS	DESIGNED	CHECKED	DATE
mm	5 : 1	1	DIS-H-006828	MI. SAKIMURA	HK. UMEHARA	12. 04. 20

  

APPROVED : KI. AKIYAMA	10. 09. 28	DRAWING NO.	EDC3-330594-01
CHECKED : OM. MIYAMOTO	10. 09. 27	PART NO.	DF59-3P-2FC(50)
DESIGNED : KT. ISHII	10. 09. 27	CODE NO.	CL667-0007-7-50
DRAWN : KT. ISHII	10. 09. 27		

# Operation Procedures for Floating Socket

## 【 Mating 】

1. Hold part A on the floating socket, and place it on the receptacle so that part A matches to part B.

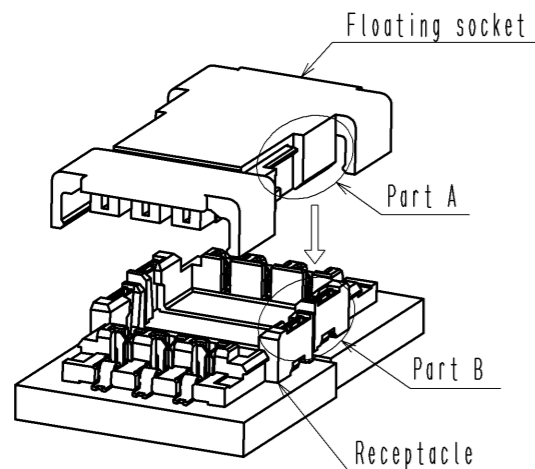

2. Align the floating socket edge on the side of friction lock to receptacle housing edge in a line.  
(Forcible mating without above alignment process could cause contact deformation.)

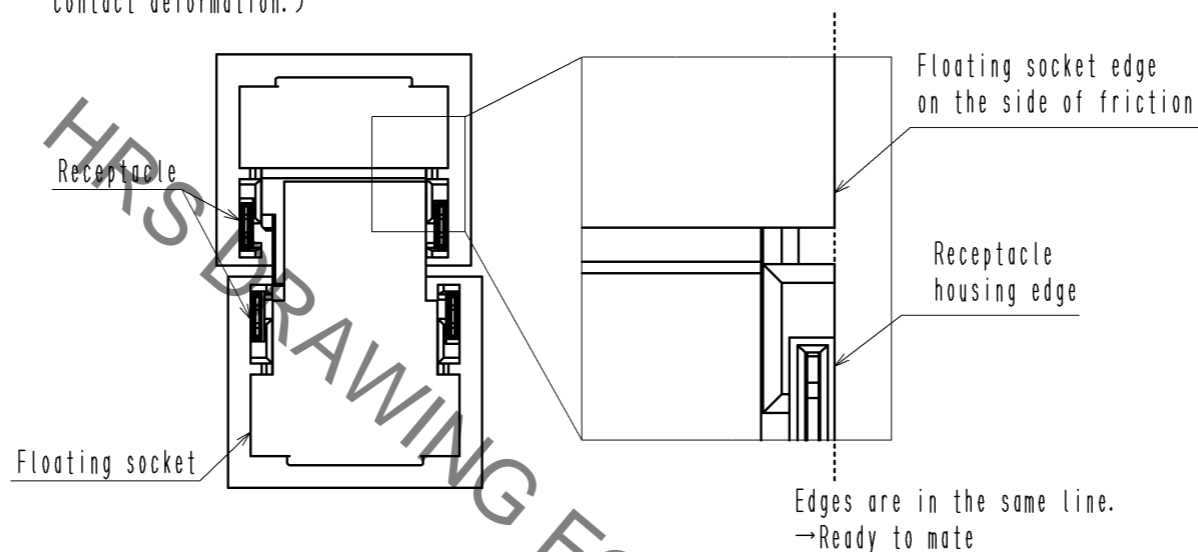

3. Press down at the center surface of the floating socket.  
(Press down until the floating socket touches to the receptacle.)

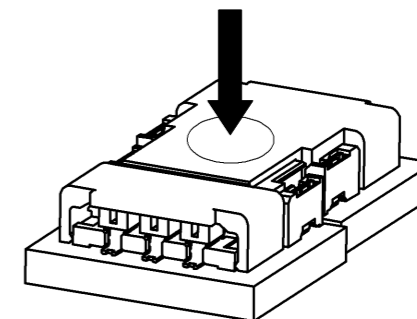

## 【 Unmating 】

1. Hook the lever on either sides of socket with finger and lift up to the upper direction for unlock.  
(Lift up until friction lock is released.)

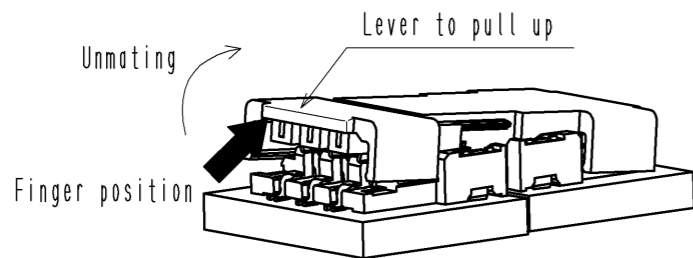

2. After releasing either side, hook the lever on the other side with a finger and lift up to the upper direction, too.

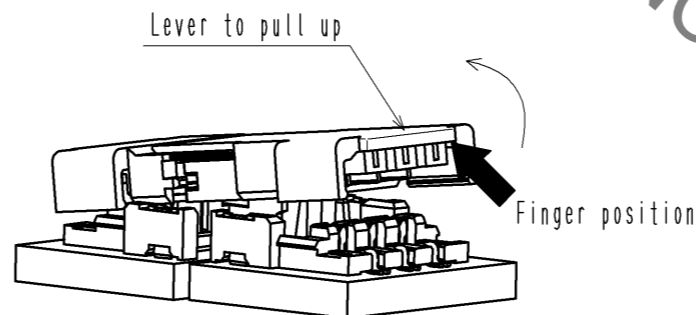

**HRS**

図番: EDC3-330594-01

製品名: DF59-3P-2FC(50)

製品コード: CL667-0007-7-50

2/2