



# **AFBR-S50**

## **Evaluation Kit Quick Start Guide**

**User Guide**  
**Version 1.3**

Copyright © 2019–2023 Broadcom. All Rights Reserved. The term “Broadcom” refers to Broadcom Inc. and/or its subsidiaries. For more information, go to [www.broadcom.com](http://www.broadcom.com). All trademarks, trade names, service marks, and logos referenced herein belong to their respective companies.

Broadcom reserves the right to make changes without further notice to any products or data herein to improve reliability, function, or design. Information furnished by Broadcom is believed to be accurate and reliable. However, Broadcom does not assume any liability arising out of the application or use of this information, nor the application or use of any product or circuit described herein, neither does it convey any license under its patent rights nor the rights of others.

# Table of Contents

<b>Chapter 1: Getting Started</b> .....	<b>4</b>
1.1 Evaluation Kit Overview .....	4
1.2 Hardware and Software Setup .....	4
1.3 Updating the Device Software .....	6
1.4 Performing a Distance Measurement .....	8
<b>Chapter 2: AFBR-S50 Explorer</b> .....	<b>10</b>
2.1 AFBR-S50 Explorer Overview .....	10
2.2 Exploring the Menu Bar .....	11
2.3 Data Visualization Views .....	14
2.3.1 1D Plot View .....	14
2.3.2 3D Plot View .....	19
2.3.3 Raw Data View .....	21
2.4 Tool Panel Overview .....	23
2.4.1 API Tab .....	23
2.4.1.1 Range Offset .....	25
2.4.1.2 Range Offset Calibration .....	26
2.4.1.3 Crosstalk Calibration .....	27
2.4.2 Summary Tab .....	28
2.4.3 Options Tab .....	29
2.5 Multi-Device Usage .....	30
<b>Appendix A: Troubleshooting and FAQs</b> .....	<b>31</b>
A.1 Related Documents .....	31
A.2 Different Versions of Explorer and Controller Board .....	31
A.3 SCI Error – No Communication to Sensor .....	32
A.4 Xtalk Calibration – 3D Plot Is Not Visible .....	32
A.5 Xtalk Calibration – Amplitude Error .....	32
<b>Revision History</b> .....	<b>34</b>
AFBR-S50-EK-UG103; March 30, 2023 .....	34
AFBR-S50-EK-UG102; November 30, 2020 .....	34
AFBR-S50-EK-UG101; May 6, 2020 .....	34
AFBR-S50-EK-UG100; December 6, 2019 .....	34

# Chapter 1: Getting Started

## 1.1 Evaluation Kit Overview

The Broadcom® AFBR-S50 evaluation kit is composed of the following main components:

- NXP FRDM-KL46Z evaluation board: Embedded microcontroller platform (ARM Cortex-M0+) used to read out the AFBR-S50 ToF sensor's data and exchange with the PC.
- AFBR-S50 adapter board: The circuit board on which the AFBR-S50 ToF sensor is mounted. It delivers out-of-box connection between the sensor and a microcontroller board without the need for soldering (just plug and play).
- USB-mini cable: Required to establish a communication between the AFBR-S50 and your system environment (for example, PC, embedded application system).

Download the software development kit (SDK) from the Broadcom website:

<https://www.broadcom.com/products/optical-sensors/time-of-flight-3d-sensors/>

Figure 1: Evaluation Kit Components

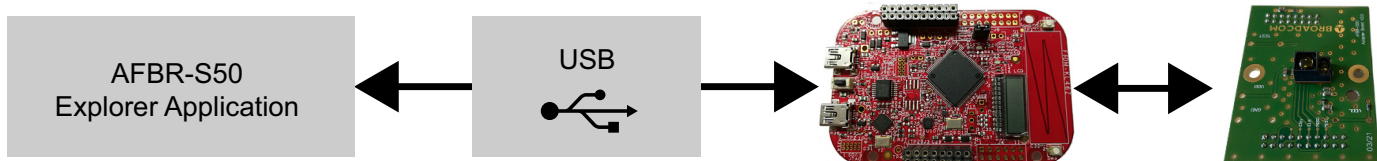

## 1.2 Hardware and Software Setup

**Step 1:** Install the main application and all necessary drivers by using the AFBR-S50 SDK setup wizard. The initial setup wizard window displays as follows.

Figure 2: Initial Setup Wizard Window

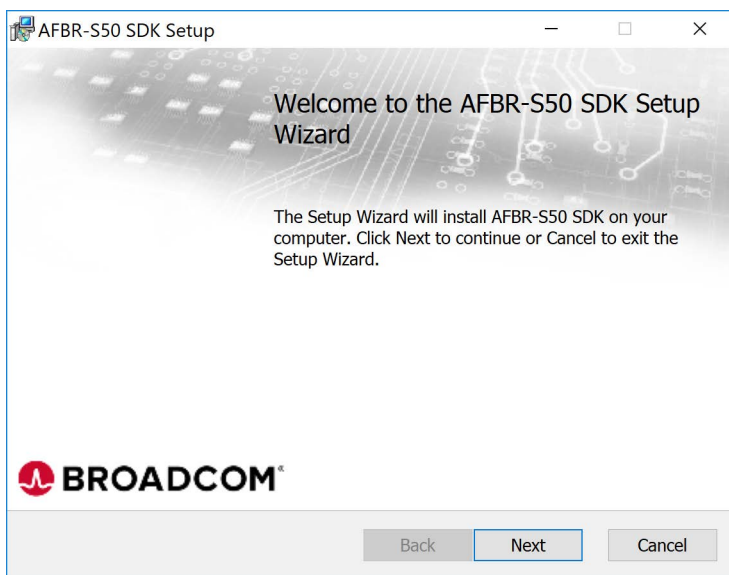

**Step 2:** Install the main driver and all additional modules to enable the full performance of the device:

**Figure 3: Installing the Device**

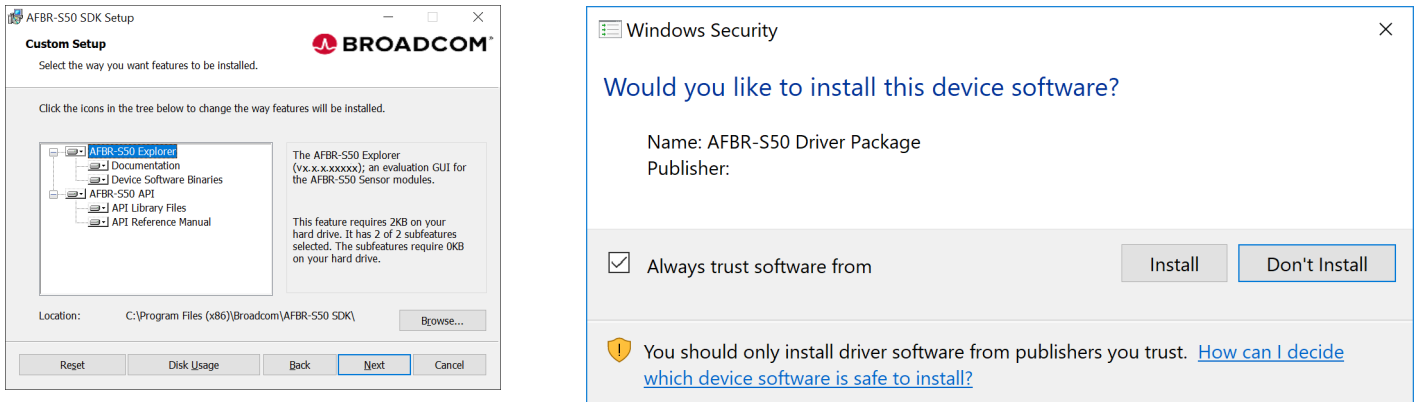

**Step 3:** Plug in the USB cable.

**CAUTION!** The correct USB port for this step is labeled as KL46Z on the bottom side of the NXP board.

**Figure 4: Connecting the USB Cable**

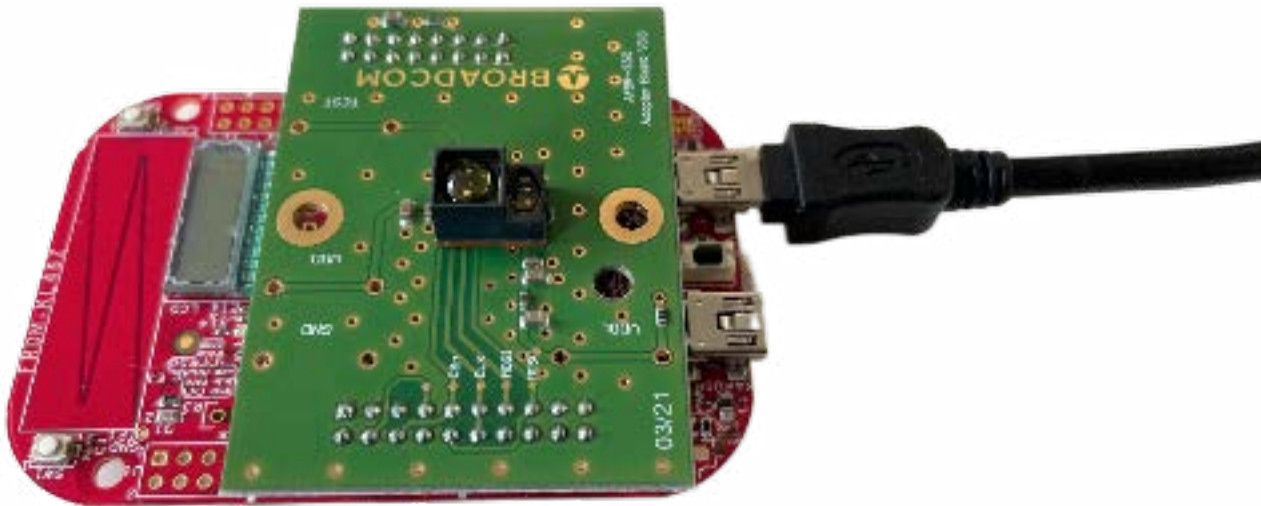

## 1.3 Updating the Device Software

When updating the AFBR-S50 SDK, the software on the evaluation kit must also be updated manually to match with the installed GUI. This is done from the AFBR-S50 Explorer App by performing the following steps:

**Step 1:** Install the desired device software, as described in [Hardware and Software Setup](#), and open the AFBR-S50 Explorer App.

**Step 2:** Connect the red AFBR-S50 evaluation board via the OpenSDA interface to the PC. An additional driver is not required.

**Figure 5: Connecting the Red Evaluation Board with OpenSDA Labeled on the Bottom Side**

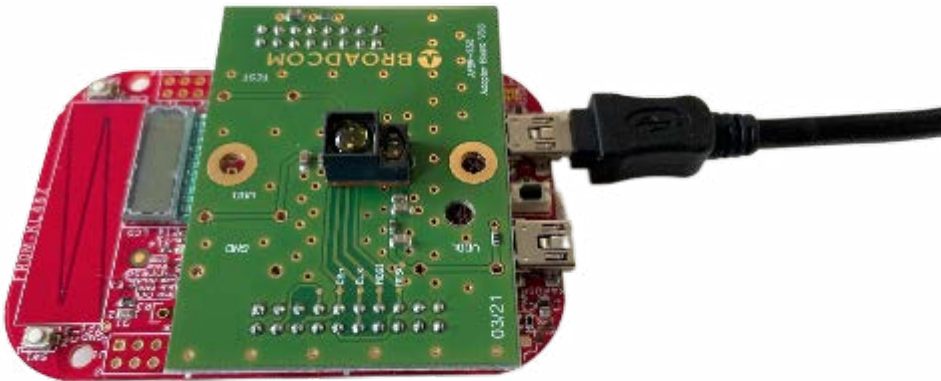

**Step 3:** In the explorer App, go to menu **Help > Flash Device Software > Flash...\_USB.srec**, and wait until the device is successfully flashed.

**Figure 6: Flash Device Software Option**

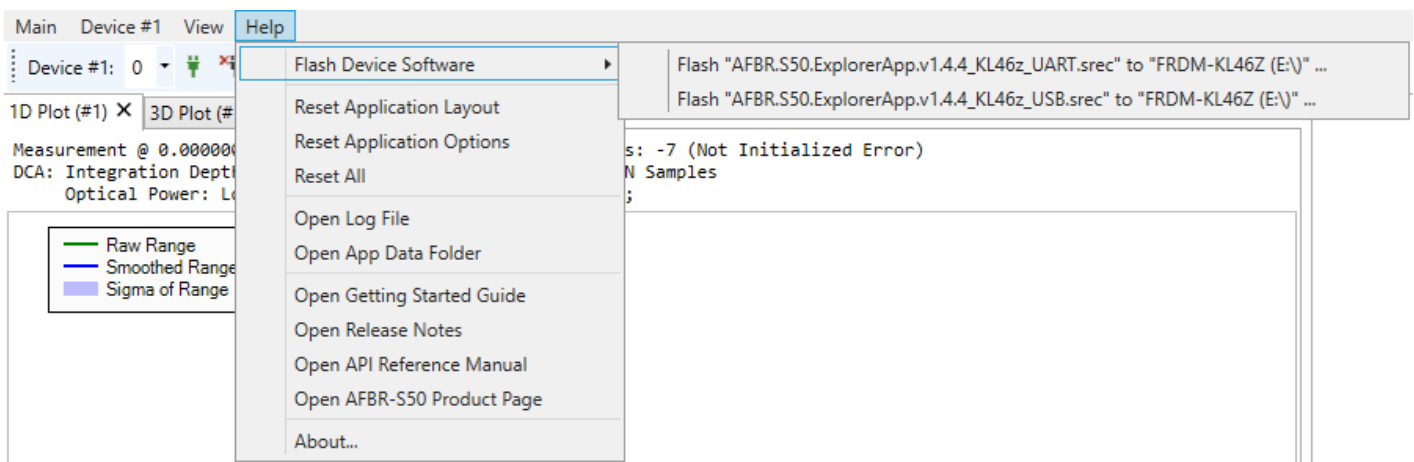

**Step 4:** When flashed successfully, connect the device using the USB port labeled with KL46Z, and run it as described in the following section.

**Figure 7: Connecting the Device Using the USB Port Labeled KL46Z**

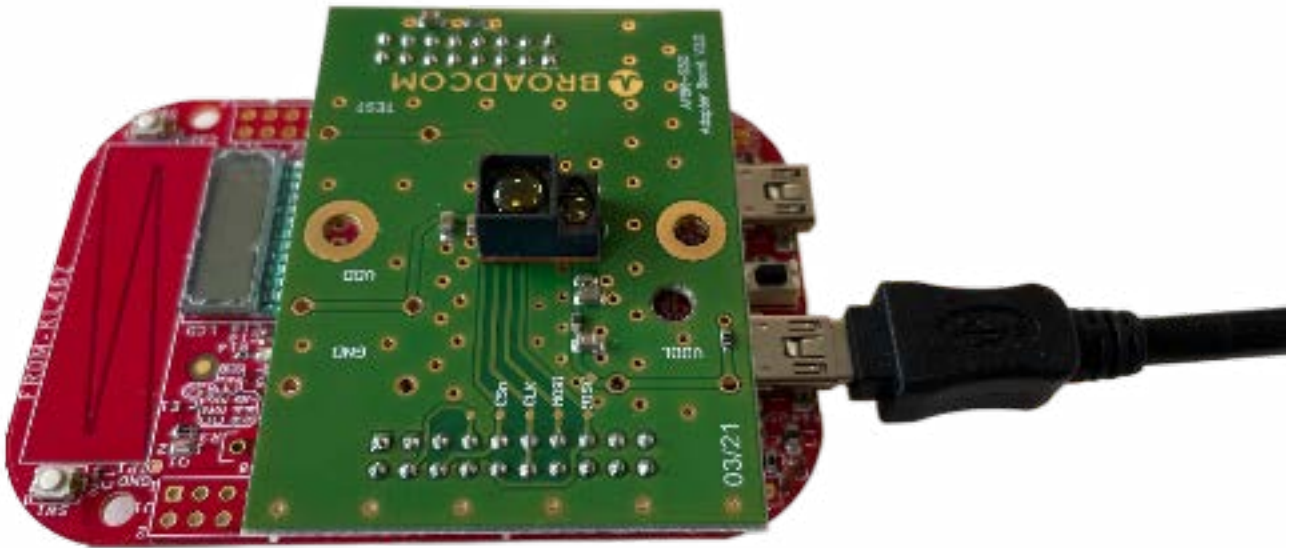

## 1.4 Performing a Distance Measurement

**Step 1:** Start the Explorer Application, *AFBR.S50.Explorer.exe*, for example, by clicking **Windows Menu > AFBR-S50 SDK > AFBR S50 Explorer**.

**Step 2:** Open a USB connection by clicking the green plug symbol.

**Figure 8: Green Plug Symbol**

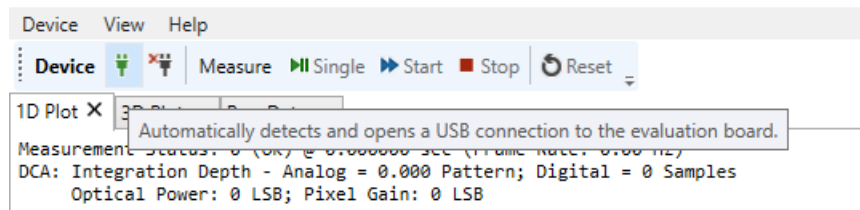

**Step 3:** Start the measurement by clicking **Start**.

**Figure 9: Starting the Measurement**

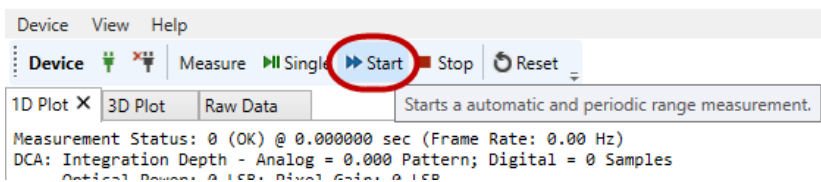

**ATTENTION:** To troubleshoot problems with starting the measurement, see [Troubleshooting and FAQs](#).

**Step 4:** Optionally, set up the device to your needs by choosing, for example, a measurement mode and frame rate both before and while measuring. The changes will immediately become effective after pressing the respective **Set** buttons on the right side of each applicable parameter.



**Figure 10: Measurement Mode after a USB Connection Has Been Opened**

Configuration API			
Measurement Mode	ShortRange	Get	Set
Data Output Mode	StreamingFull	Get	Set
Frame Rate [Hz]	25	Get	Set
Dual Frequency Mode	X8	Get	Set
Shot Noise Monitor Mode	Dynamic	Get	Set
Crosstalk Monitor	<input checked="" type="checkbox"/>	Get	Set
Pixel Binning Algorithm (PBA)			
Enable PBA	<input checked="" type="checkbox"/>		
Averaging Mode	LAWA		
Absolute Amplitude Threshold [LSB]	20		
Relative Amplitude Threshold	0.5		
Absolute Minimum Distance Threshold [m]	-0.010		
Minimum Distance Scope Enable	<input checked="" type="checkbox"/>		
Absolute Minimum Distance Scope [m]	0.050		
Relative Minimum Distance Scope	0.04	Get	Set

**NOTE:** Information from the Configuration API section is loaded when a device is successfully connected to the explorer app. The PBA default values differ among the sensor types.

## Chapter 2: AFBR-S50 Explorer

This section is intended to make the user familiar with the graphical user interface (GUI) of the AFBR-S50 Explorer application and support the evaluation of a given ToF sensor device.

The AFBR-S50 Explorer software connects to the AFBR-S50 evaluation board using the USB interface. It receives the measurement data from the device software running on the NXP board's microcontroller and displays it in a convenient way. Furthermore, the ToF sensor device can be configured and calibrated by using the AFBR-S50 Explorer GUI.

### 2.1 AFBR-S50 Explorer Overview

Open the AFBR-S50 Explorer. The following screen is displayed.

Figure 11: AFBR-S50 Explorer Display Screen

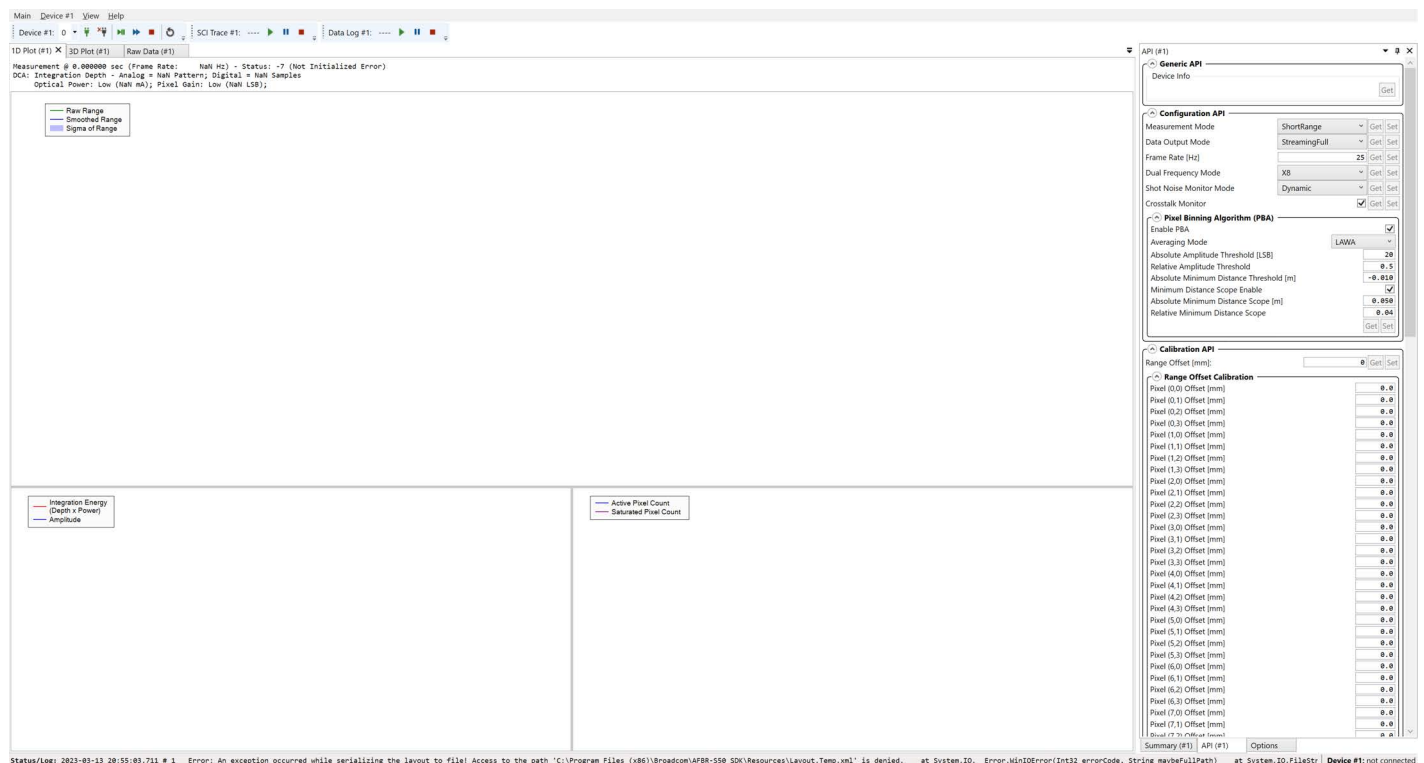

The AFBR-S50 Explorer main window consists of the following five basic elements:

1. Menu bar
2. Controller tool bar
3. Data visualization windows
4. Tool windows
5. Status bar

## 2.2 Exploring the Menu Bar

The AFBR-S50 Explorer menu bar includes the following three elements:

- Device
- View
- Help

**Figure 12: Device Menu**

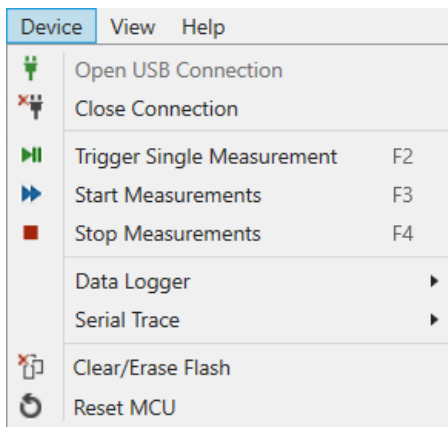

From the Device menu, options are available to open and close the USB connection, trigger measurements, create a log data file over a data logger to store measurement data, monitor and store the communication of the serial interface, and, once connected, reset the microcontroller on demand.

All data measured by the ToF sensor device can be logged to a file for plotting and evaluating the measurement results. The log file is saved to the entered path.

**Figure 13: Data Logging Options**

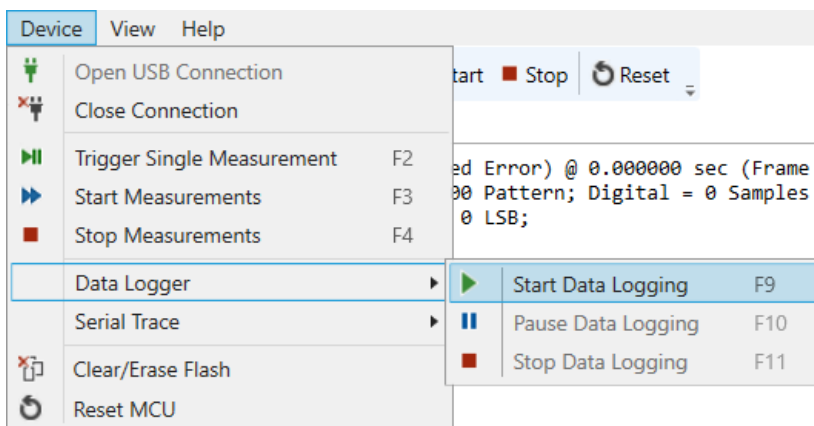

The data logger starts recording once a destination path and file are chosen. In addition, another small menu bar for the data logger is available.

After clicking **Stop**, a message appears in the explorer application with the information and the saved number of samples.

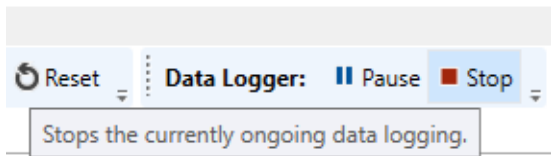
**Figure 14: Data Logger Recording Options**

**NOTE:** The amount of data of the data logger output file can be changed by choosing a different data output mode from the Configuration API in the API section if Advanced Mode is enabled in tab options, section API Options (see also [Section 2.4.3, Options Tab](#)).

For formatting reasons, open the created log file either with an advanced text application (for example, Notepad++) or import it directly into a data analysis program. Another helpful debug feature is to perform a Serial Trace of all the bus transfers between the microcontroller and the connected device. After the start of a Serial Trace, the application asks for a path to save the Serial Trace Data. Both the Measurement Log Data and the Serial Trace are saved as .txt files.

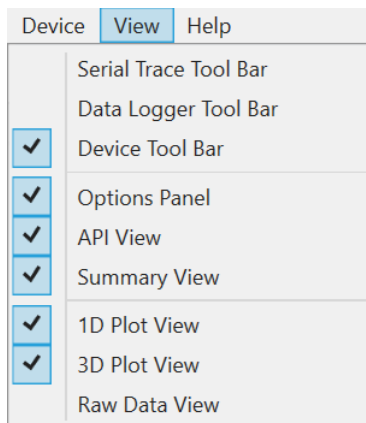
**Figure 15: View Menu**

Single view modules can be enabled or disabled in the Explorer app with the **View** menu.

The **Help** menu is used to flash the current AFBR-S50 device software to the connected microcontroller, open the latest status message log, reset the application values to default, and provide additional links to all necessary documentation on the SDK.

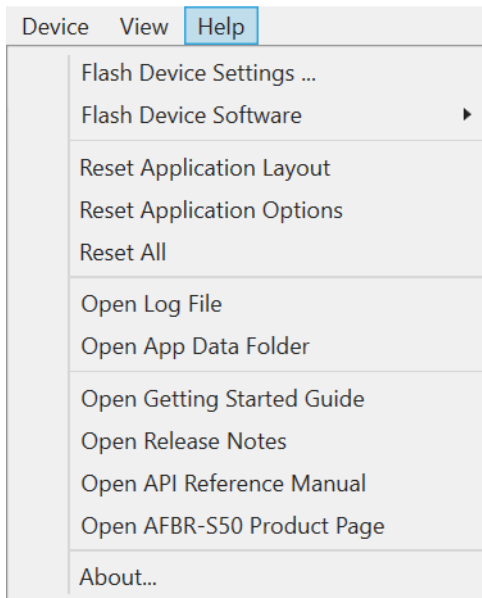
**Figure 16: Help Menu**

The AFBR-S50 Controller Tool Bar gives quick access to the most important operation elements regarding measurement and Reset of the microcontroller. On the left it delivers a simple connect and disconnect menu to open up a connection via USB port to the microcontroller on the evaluation kit board.

- **Single:** Sends a trigger signal to the device to perform a single measurement frame. Afterwards the device goes to idle state.
- **Start:** Starts a periodic measurement loop.
- **Stop:** Stops the periodic measurement loop and makes the device go to idle state. Note that this only stops the measurement loop and prevents new measurements to be triggered. However, it does not stop a currently ongoing measurement frame.

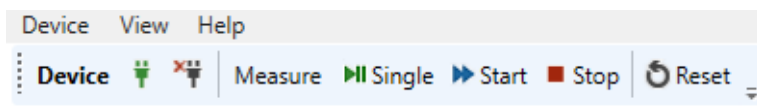
**Figure 17: AFBR-S50 Controller Tool Bar**

## 2.3 Data Visualization Views

Below the AFBR-S50 Controller Tool Bar, all measurement data gathered by the ToF sensor device can be displayed in three different views: 1D Plot, 3D Plot, and Raw Data. Each of the three views are introduced in the next sections.

Unlike the different views, the Measurement Status is always shown and gives information on the timestamp of the measured signal, the corresponding frame rate, the Dynamic Configuration Adaption (DCA, the number of Digital averaging Samples), optical power, and the pixel gain.

**NOTE:** The displayed Frame Rate may differ depending on the characteristics of your serial connection (for example, USB cable length, and so on).

**Figure 18: Measurement Status Example**

```
Measurement Mode B: Short Range @ 457.715024 sec (Frame Rate: 25.0 Hz) - Status: 0 (OK)
DCA: Integration Depth - Analog = 0.406 Pattern; Digital = 115 Samples
Optical Power: High (55 mA); Pixel Gain: MediumHigh (29 LSB);
```

### 2.3.1 1D Plot View

The 1D Plot View consists of three plots and shows the measurement data in real time. It is the standard measurement view displayed after the first start of a measurement. The x-axis for every chart inside the 1D plot View reflects the number of measurement samples.

- Range Plot
- Amplitude Plot
- Pixel Count Plot

**Figure 19: 1D Plot View GUI**

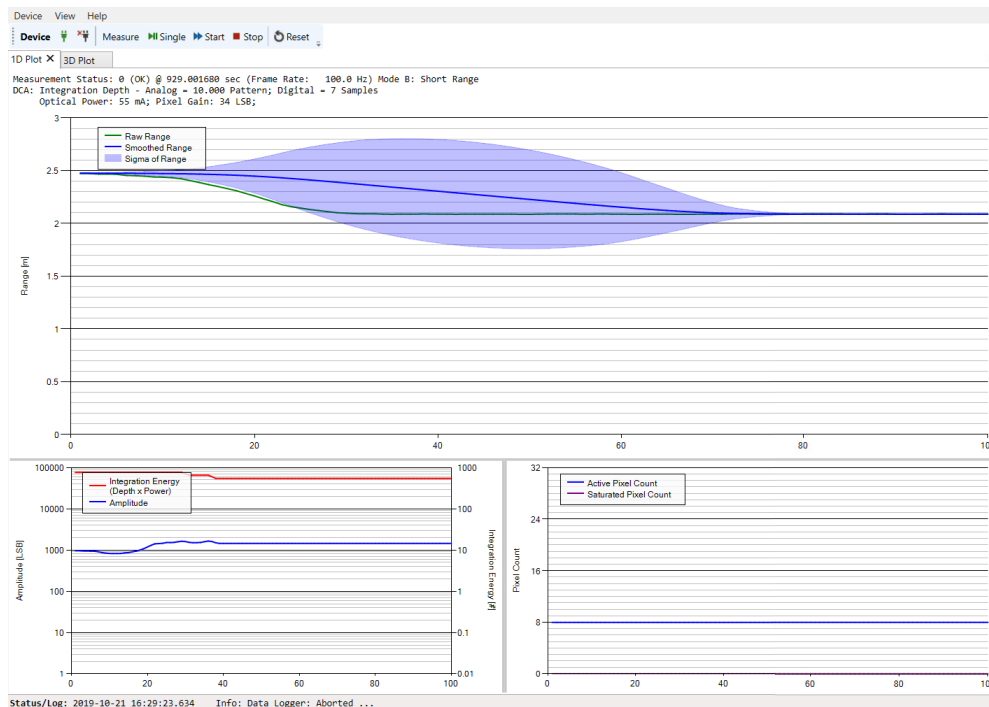

The Range plot element of the 1D Plot View is able to display up to four different range plots:

- **Binned Range:** Plots the average range over all pixels that are determined by the pixel binning algorithm. This value represents the current range in meters.
- **Smoothed Binned Range:** Plots a time based moving average of the Binned Range. To adjust the algorithm of the time-based moving average, go to the 1D Plot Options View inside the Options tab. A greater SMA data buffer size may result in a slower moving visualization.

**Figure 20: Generic Data View Options**

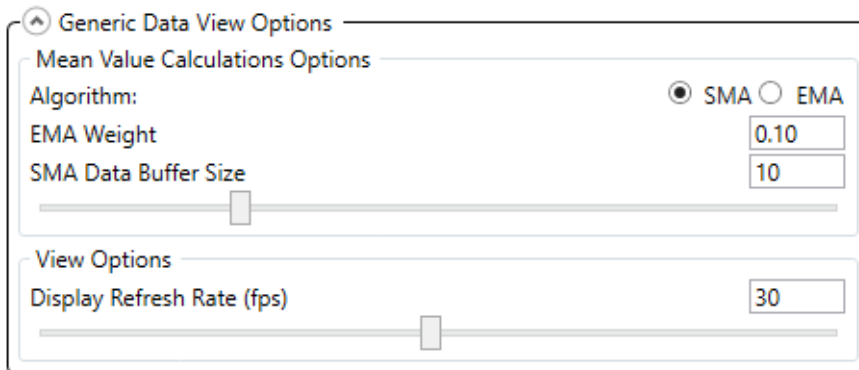

Choose between two different algorithms used for calculation of the averaged measurement results:

- **Simple Moving Average:** The mean calculated of the previous N data without any weighting. The SMA Data Buffer Size defines the magnitude used for SMA calculations.
- **Exponentially Weighted Moving Average:** A type of an infinite impulse response filter that applies exponentially decreasing weighting factors. The weighting for each older datum decreases exponentially but never reaches zero. EMA Weight implies the quantifier used for the calculation of the EMA. Lower values result in less weighting of past measurement outcome and thus longer averaging times.
- **Sigma of Binned Range:** The blue cloud determines the current time based on moving the standard deviation of the sensor signal; inside the 1D Plot Options, choose between a deviation width of 1 Sigma and 3 Sigma.

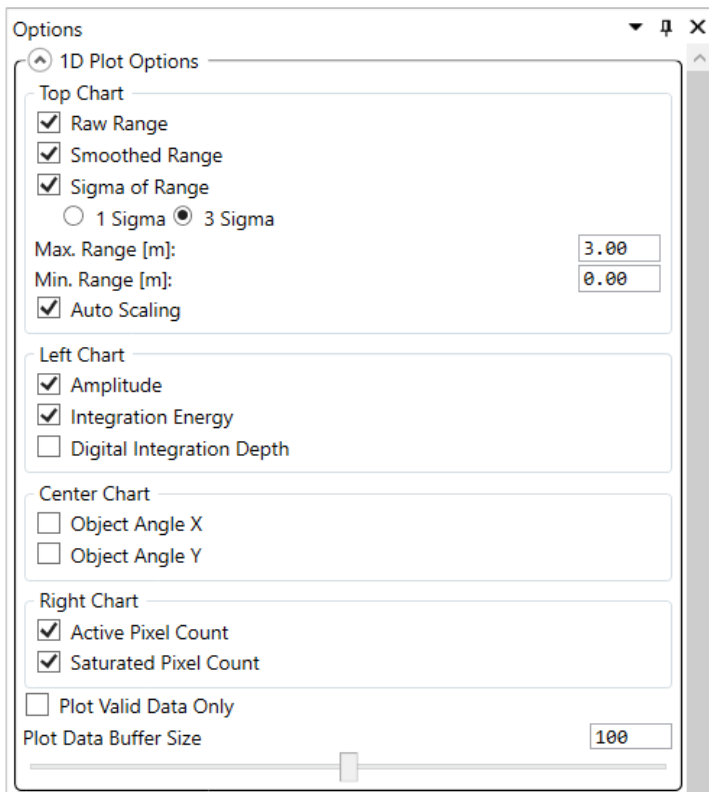
**Figure 21: 1D Plot Options**

The different plots of the Range plot element can be turned either on or off by selecting the respective check boxes inside the Options Panel. It is also possible to change the minimum and maximum displayed range of the respective axis or select the Auto Scaling option.



Figure 22: 1D Plot Options

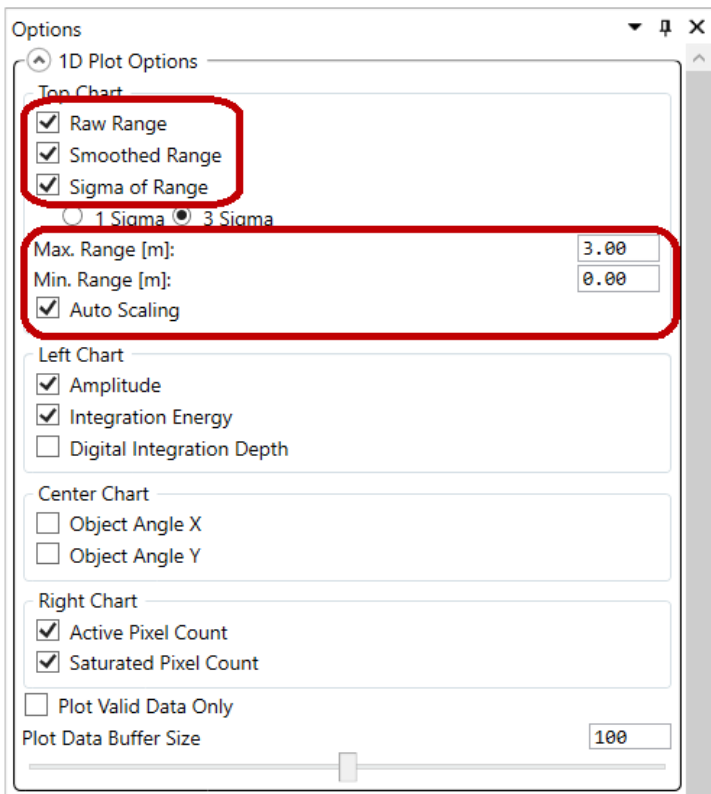
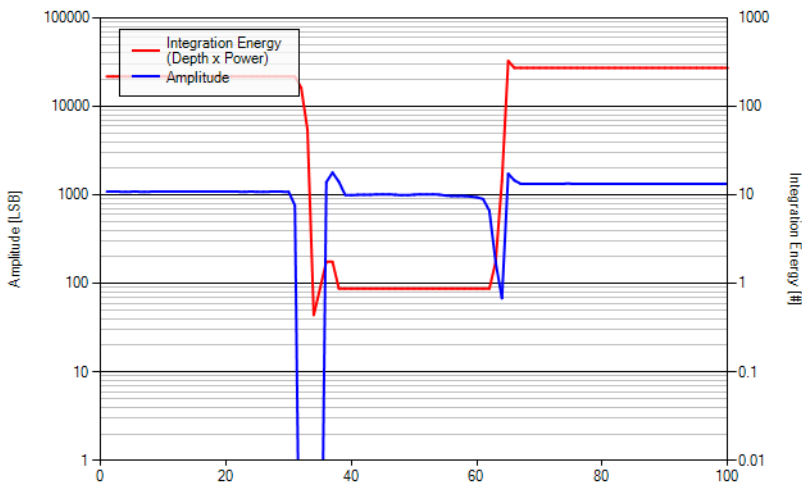
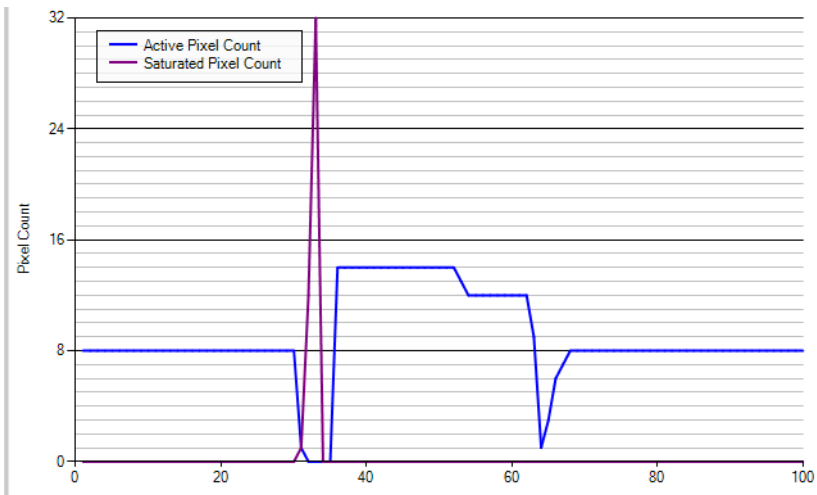

Figure 23: 1D Plot Example



- Integration Energy: Calculated by the integration depth per sample times the optical output power.
- Amplitude (Maximum) Plot: Shows the current maximum measurement signal amplitude, which is determined by all pixels that are selected by the Pixel Binning Algorithm.

**Figure 24: Active Pixel Count vs. Saturated Pixel Count**

- **Active Pixel Count:** The value of Active Pixel Count reveals the number of pixels that are used for calculating range and amplitude with respect to the current Pixel Binning Algorithm.
- **Saturated Pixel Count:** The value of Saturated Pixel Count reveals the number of pixels being in saturation state due to too much optical power received.

## 2.3.2 3D Plot View

The second tab of the Data Visualization Window opens the 3D Plot View revealing more pixel-specific information on the measured range and amplitude in real time:

**Figure 25: 3D Plot View**

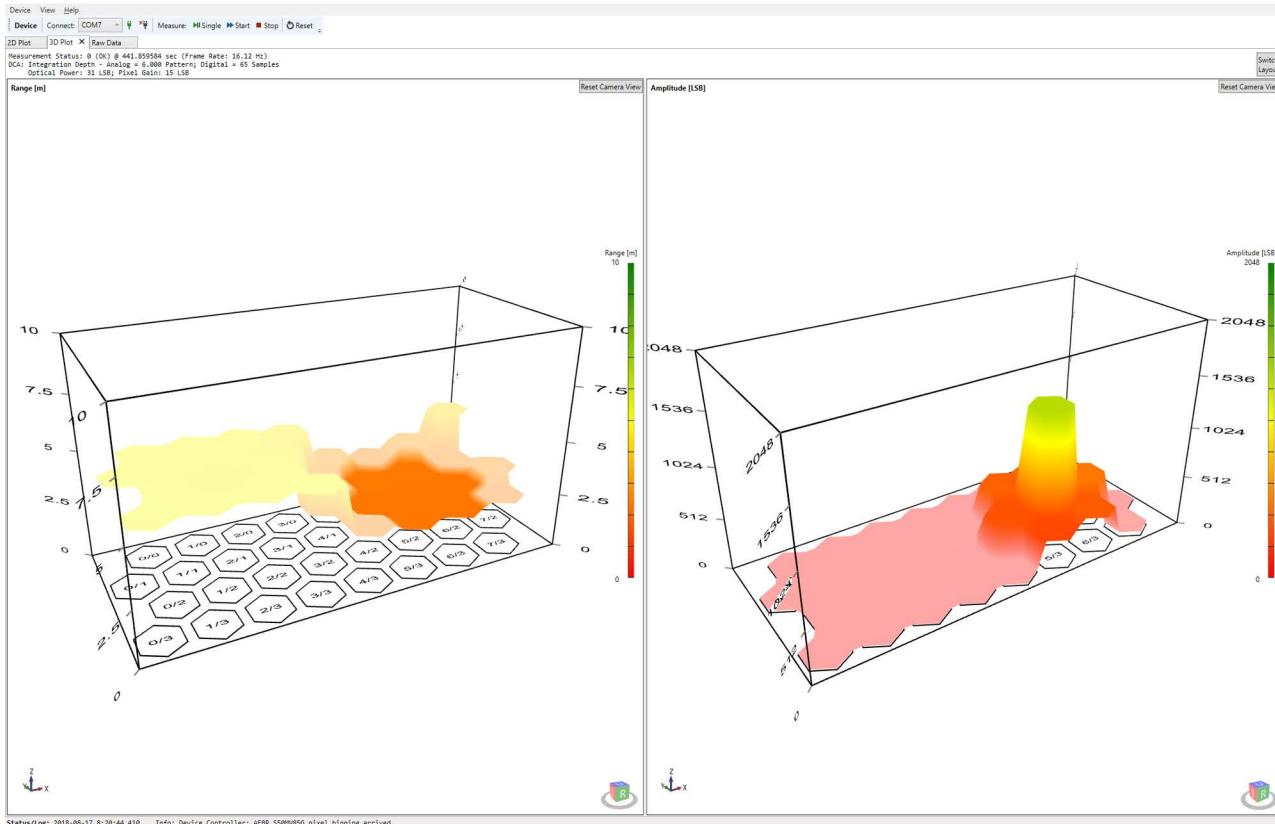

This 3D Plot View shows the retrieved measurement signal of every single pixel of the sensor's pixel matrix.

- **3D Range:** The left plot shows the time based average range values for each available pixel.
- **3D Amplitude:** The right plot inside the 3D plot view shows the time based average amplitude values for each available pixel.

There is also a Color axis for each of the two 3D plots that highlights the corresponding signal magnitude.

Hide binned pixels to see only pixels considered valid for the measurement by enabling the **Hide Binned Pixels in Plots** option in the 3D Plot options tab.

Figure 26: Hide Binned Pixels Option

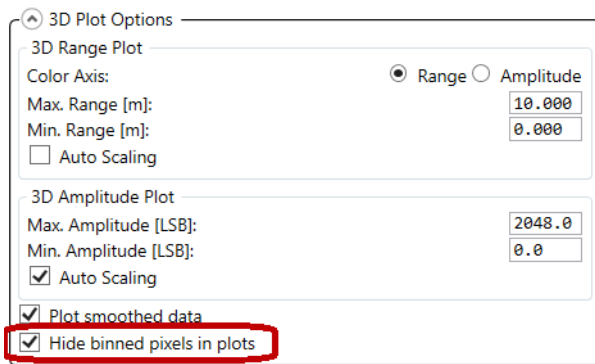

Invalid pixels that do not satisfy the binning criteria will disappear from the plot.

Figure 27: Hidden Binned Pixels

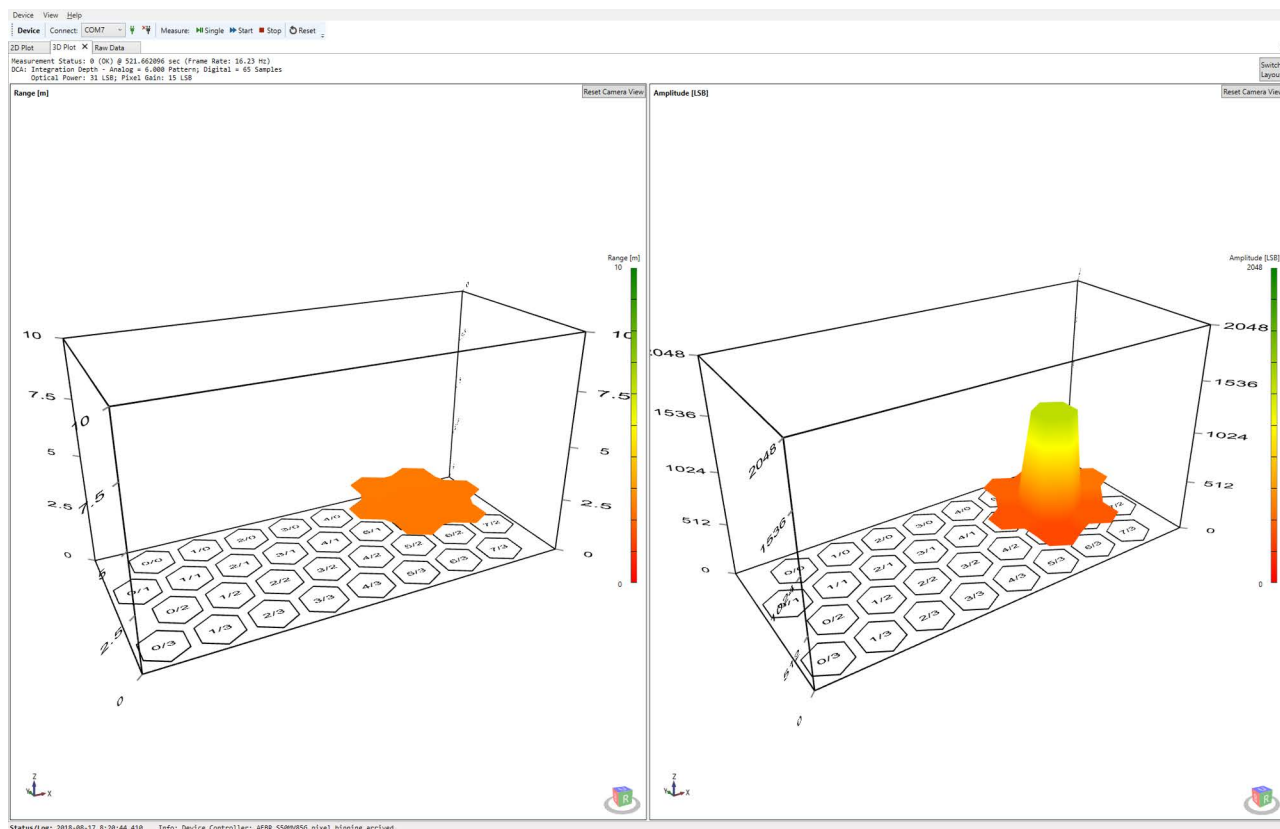

For a closer look at each pixel, zoom and rotate the 3D plots using the mouse.

- To move a plot, click and hold the scroll wheel.
- Rotate the plots by clicking and holding the right mouse button.
- Use the scroll wheel to zoom in and out.
- Double-click the scroll wheel to reset a plot to its default point of view.

## 2.3.3 Raw Data View

The raw data view is not visible by default, it has to be enabled in the help menu first.

**Figure 28: Enabling the Raw Data View**

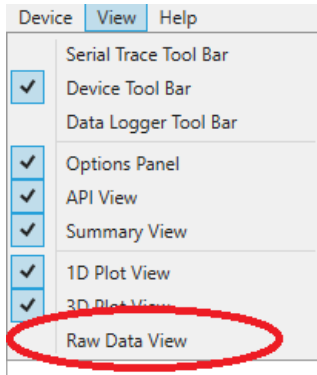

Raw Data view gives additional details about each pixel's measured range and amplitude results including the corresponding mean values and signal deviations (referred to as sigma). Furthermore, Mean and Sigma of both Raw Range and Raw Amplitude can be displayed as either SMA or EMA weighted (Mean(s), Mean(e), Sigma(s), Sigma(e)). The above screenshot shows not all Pixels for reason of better overview. Keep in mind that the choice of SMA and EMA affect the displayed values of Sigma and Mean in different ways.

**Figure 29: Raw Data View**

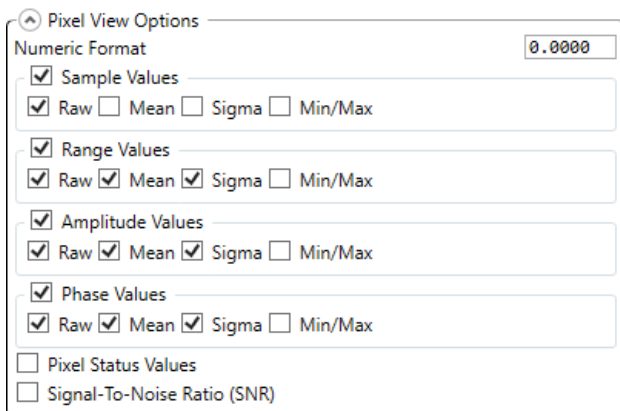

By enabling the **Pixel Status Values** check box, the Raw data view displays several status flags for each pixel.

**Figure 30: Single Pixel Status**

```

Pixel (5,2)
Status: 0b00000000
- Saturated: False
- 1D Binned: True
- Ampl. Min: False
- Pre-Filt.: False
- No Signal: False
- OutOfSync: False
- Stalled: False
Range:
Raw:      1.0140
Mean(s):  1.0146
Sigma(s): 0.4428
Amplitudes:
Raw:      497.9375
Mean(s):  498.4213
Sigma(s): 0.4428

```

For a detailed description of the single statuses, open the API reference manual and type `argus_px_status_t` in the search field.

Choose which of the results to keep visible or hidden by selecting the associated Pixel View Options from the Options Panel. In addition, the Numeric Format of the displayed results can be adapted.

**Figure 31: Pixel View Options**

**Pixel View Options**

Numeric Format

Sample Values

Raw  Mean  Sigma  Min/Max

Range Values

Raw  Mean  Sigma  Min/Max

Amplitude Values

Raw  Mean  Sigma  Min/Max

Phase Values

Raw  Mean  Sigma  Min/Max

Pixel Status Values

Signal-To-Noise Ratio (SNR)

## 2.4 Tool Panel Overview

This section introduces the tool panel which is located on the right side of the explorer GUI.

**Figure 32: Location of the Tool Panel in the GUI**

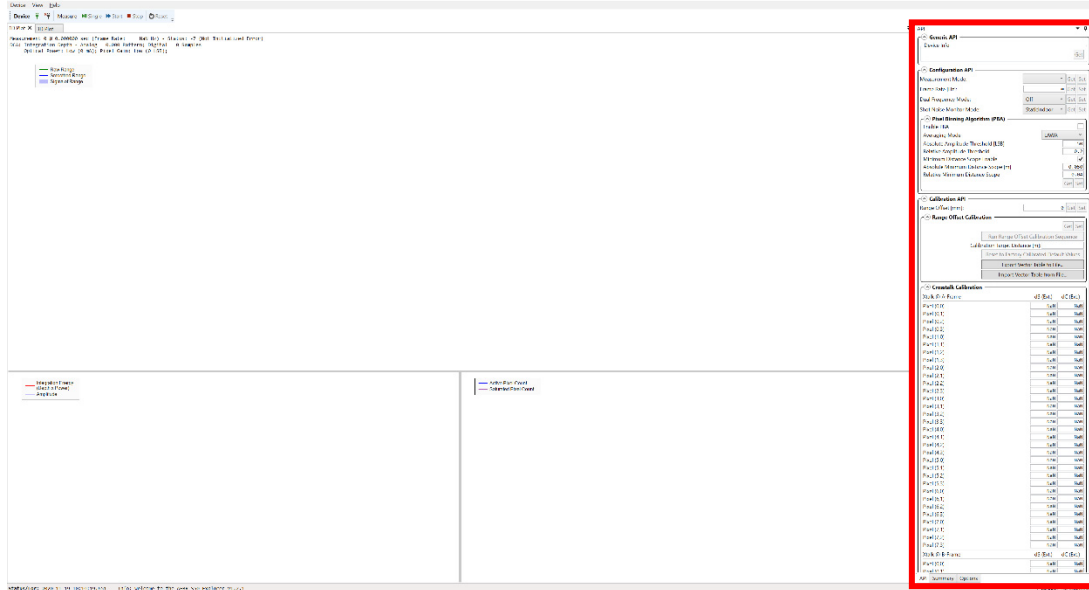

### 2.4.1 API Tab

In general, this tab is organized in the three categories: Generic API, Configuration API, and Calibration API. All functions and accessible parameters shown in this section give an overview about the interoperability with an AFBR-S50 sensor. As indicated in [Figure 33](#), applicable settings have a **Get**, **Set**, or both button on the right side to either retrieve the current parameter setting from the sensor (**Get**) or send a new target setting to the sensor (**Set**).

**Figure 33: Configuration API with Get/Set Buttons**

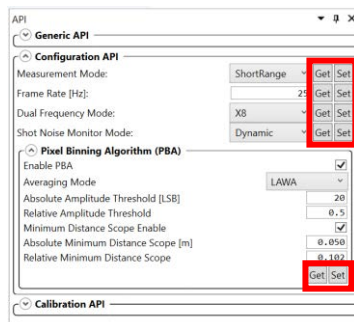

#### Generic API

When the connection to the evaluation board is established, the Generic API section is filled with important information on the device, such as the API and explorer version number, module type, chipID, and so on.

## Configuration API

This is the category where users can modify basic settings of the sensor, such as the measurement mode, frame rate, dual frequency mode, shot noise monitor mode as well as optimizing the pixel binning algorithm settings. However, because all predefined settings are based on empirical data for best sensor operation, there is no need to change unless there is a known reason.

Figure 34: Configuration API

API (#1) ▼ □ ✕

▼ **Generic API**

▲ **Configuration API**

Measurement Mode	ShortRange	▼	Get	Set
Data Output Mode	StreamingFull	▼	Get	Set
Frame Rate [Hz]	25		Get	Set
Dual Frequency Mode	X8	▼	Get	Set
Shot Noise Monitor Mode	Dynamic	▼	Get	Set
Crosstalk Monitor	<input checked="" type="checkbox"/>		Get	Set

▲ **Pixel Binning Algorithm (PBA)**

Enable PBA	<input checked="" type="checkbox"/>
Averaging Mode	LAWA
Absolute Amplitude Threshold [LSB]	20
Relative Amplitude Threshold	0.5
Absolute Minimum Distance Threshold [m]	-0.010
Minimum Distance Scope Enable	<input checked="" type="checkbox"/>
Absolute Minimum Distance Scope [m]	0.050
Relative Minimum Distance Scope	0.04
	Get Set

▼ **Calibration API**

## Calibration API

In general, each AFBR-S50 ToF sensor is factory calibrated and immediately ready to take measurements. When it comes to a system integration, it may be necessary to optimize the performance for a specific application, which can be carried out by the calibrations offered in this section of the API tab. It consists of two main subsections, which are the Range Offset Calibration and the Crosstalk Calibration.

Figure 35: Subsections of Calibration API

▲ **Calibration API**

Range Offset [mm]:  Get Set

▼ **Range Offset Calibration**

▼ **Crosstalk Calibration**



### 2.4.1.1 Range Offset

This parameter gives you the opportunity to compensate application-specific distance offsets. If the ToF sensor is part of a system that has another reference edge for assessing the distance, the offset between sensor and this reference edge must be defined with the Range Offset parameter.

$$\text{Formula: Range} = \text{RawRange} - \text{RangeOffset}$$

Figure 36: Range Offset

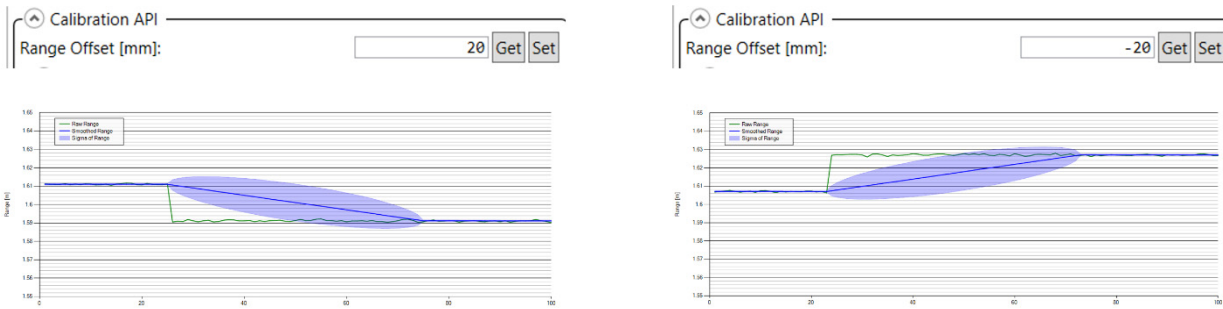

**NOTE:** Be careful when setting this parameter because range values may turn negative.

### 2.4.1.2 Range Offset Calibration

Unlike the Range Offset parameter, which affects the binned range value, the following pixel offset from table shown in [Figure 37](#) intends to do the same for each single pixel range by performing a calibration on a reference plane. The distance in meters to the reference plane can be entered in **Calibration Target Distance [m]** field. After clicking the **Run Range Offset Calibration Sequence** button, the table is filled with the values and distance offsets that are written to the sensor. The generated calibration data can also be imported and exported for further processing or analysis. Single offset values can also be modified and requested by using the **Get** and **Set** buttons.

The main purpose of this calibration procedure is to enable and improve gesture detection applications by minimizing the range offset among the single pixels of the 32-pixel array on the receiving side. The effect of this calibration is depicted in [Figure 38](#).

Figure 37: Range Offset Calibration Table

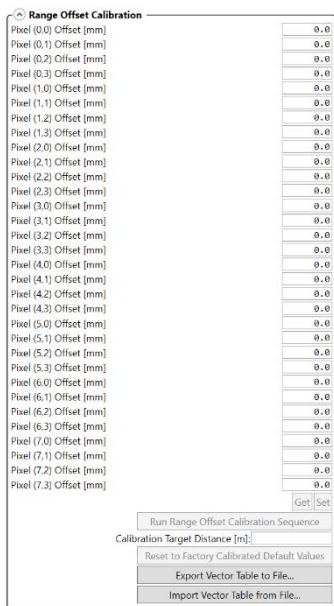
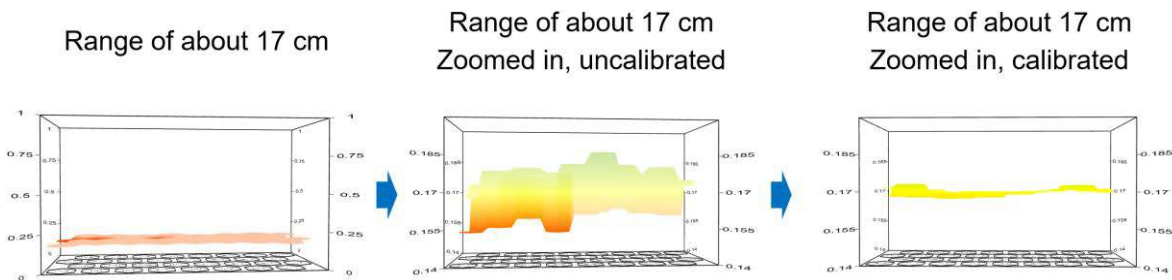

Figure 38: Effect of a Pixel-to-Pixel Range Offset Calibration



### 2.4.1.3 Crosstalk Calibration

Crosstalk (Xtalk) calibration is suggested to be carried out for each system design with implemented AFBR-S50 sensors. It targets to compensate electrical crosstalk possibly generated by the application PCB, as well as optical crosstalk generated by a cover glass mounted above the sensor and therefore affecting its optical path.

The following example shows the calibration of electrical crosstalk. For a full calibration of electrical and optical crosstalk (for example, due to usage of a cover glass), refer to the crosstalk calibration application note.

#### Example Calibration Sequence for Electrical Xtalk Compensation Only

1. Blind the sensor with a foam while taking measurements, and make sure that the amplitudes are roughly as low as shown in the following figure.

**Figure 39: Blinding Sensor for Xtalk Calibration**



2. Click **Run Crosstalk Calibration Sequence** located in the **API** tab.

**Figure 40: Crosstalk Calibration Amplitude**

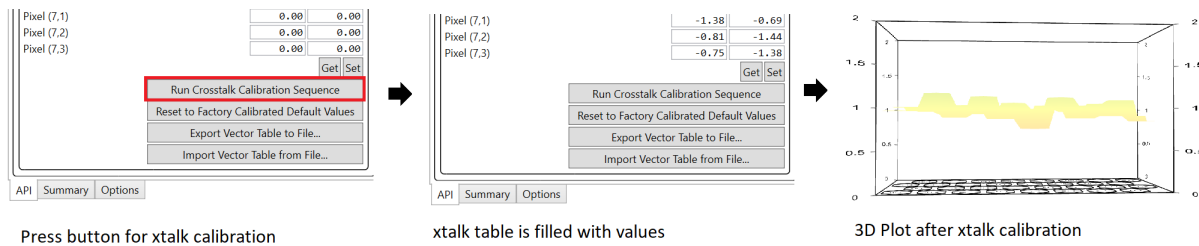

The Xtalk vector table is immediately applied to all pixels. For further information, refer to the information in the cover glass calibration guide.

## 2.4.2 Summary Tab

The **Summary** tab shows current measurement results as well as generic and DCA information. As the last part of the measurement results section, the auxiliary parameters give the user additional information on the internal voltage and current levels in units of the ADC, the ASIC temperature and environmental information, such as a Background light indicator (in arbitrary units), and the connected shot noise amplitude.

**Figure 41: Summary Tab**

Summary	
<b>Generic</b>	
Status:	OK (0)
Timestamp:	644.180784 s
Frame Rate (actual value):	25.00 Hz
Measurement Mode:	Mode B: Short Range
Frame Frequency:	A-Frame
PIL Locked:	100 % <input checked="" type="checkbox"/>
Background Light Warning:	<input type="checkbox"/>
Background Light Error:	<input type="checkbox"/>
<b>DCA Information</b>	
Digital Integration Depth	94 Sampl.
Analog Integration Depth	8 Pattern
Optical Power Stage	High
Optical Power Value	7.1 mA
Pixel Gain Stage	MediumLow
Pixel Gain Value	38 LSB
<b>1D Measurement Results</b>	
Raw Range	2.875 m
Smoothed Range	2.871 m
Sigma Range	11.73 mm
Amplitude	74.3 LSB
Smoothed Amplitude	74.4 LSB
Sigma Amplitude	0.73 LSB
Pixel Count	1 Pixel
<b>3D Measurement Results</b>	
Amplitude (Pixel Average)	6.2 LSB
Amplitude (Pixel Maximum)	74.3 LSB
Saturated Pixel Count	0 Pixel
<b>Auxiliary Measurement Results</b>	
Supply Voltage (VDD)	2785.1 LSB
Laser Supply Voltage (VDDL)	2759.7 LSB
Substrate Voltage (VSUB)	3333.3 LSB
APD Current (IAPD)	1996.7 LSB
Temperature (T)	35.4 °C
Background Light (BGL)	2.4
Shot Noise Amplitude (SNA)	2.3 LSB

## 2.4.3 Options Tab

All of the available tab settings were already explained except for the API Advanced Options. These options give advanced users the possibility to further modify the PBA or DCA settings, which can be unlocked by selecting the **Advanced Mode** check box as shown in the figure below.

Figure 42: Advanced Mode – API Options



When selected, the user can access more parameters that have appeared in the **API** tab, which enable a refinement of PBA and DCA settings. Tooltips provide more information about each parameter.

Figure 43: API Advanced Options Example Shown for the Configuration API Section

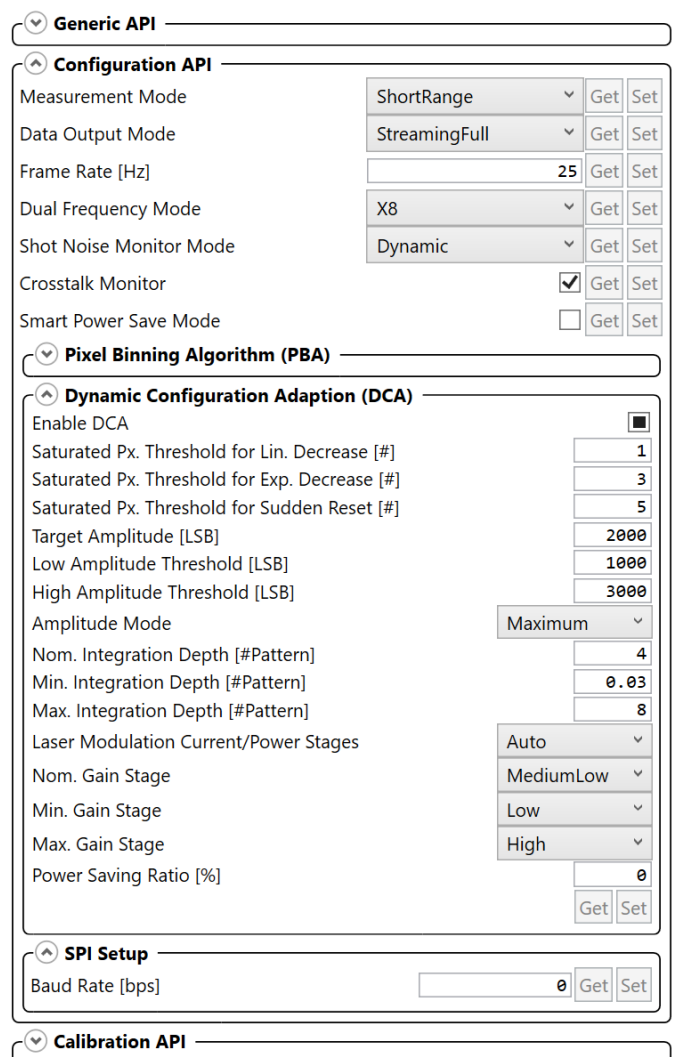
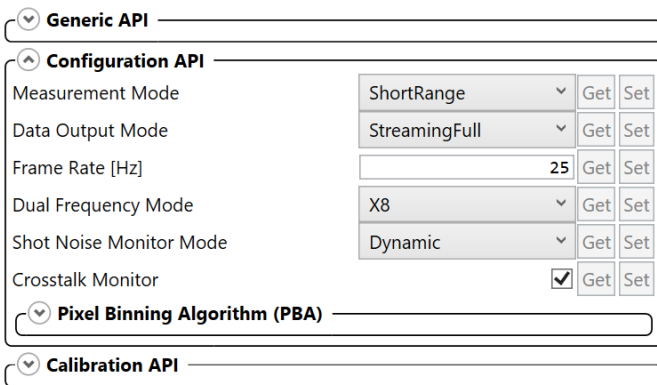

## 2.5 Multi-Device Usage

From v1.4.4 on multi-device controls and views via one MCU are implemented in the AFBR-S50 explorer application. Click **Main**, **Add new AFBR-S50 Device**. The new views for a second device display on the screen.

Figure 44: Add New Device

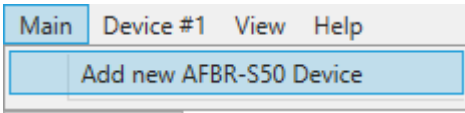

Each device can be controlled individually with its own controller toolbar. Addresses are assigned automatically.

Figure 45: 1D View of Four Sensors Running in Parallel in One AFBR-S50 Explorer Instance

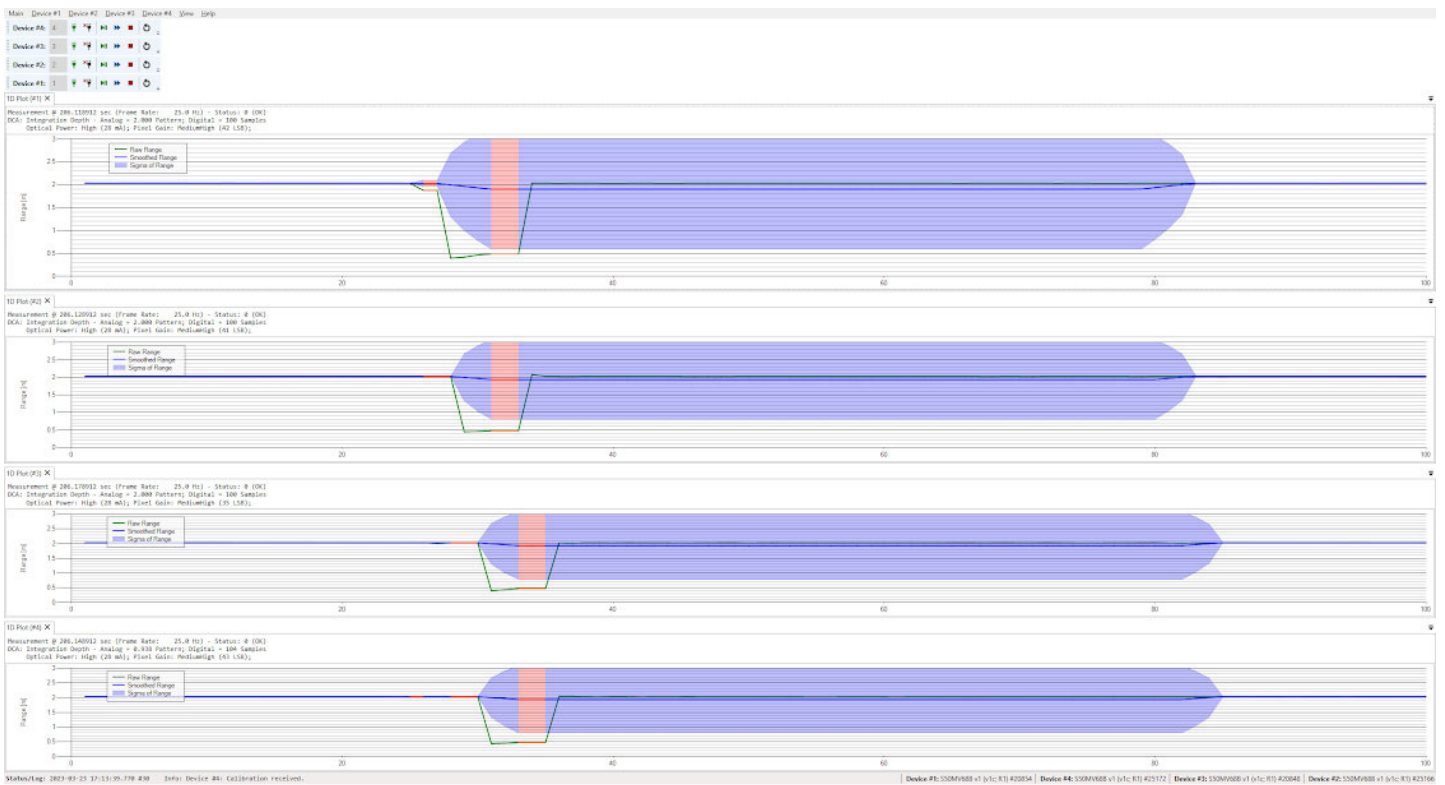

# Appendix A: Troubleshooting and FAQs

## A.1 Related Documents

- *AFBR-S50xxxxx Data Sheet*
- *AFBR-S50 Software Release Notes*

## A.2 Different Versions of Explorer and Controller Board

If an error message indicates that the software versions of the AFBR-S50 Explorer and microcontroller device software do not match, you may have an older or incompatible FW running on the evaluation board.

**Figure 46: Error Message**

```
Device Software Version (0.9.5) do not fit to the Explorer Version (1.x.x)!
The systems communication interface is probably incompatible.
Please update your software.

SCI: Deserialization error on received frame! Command: Configuration (configuration);
SCI: Rx Frame too short.

SCI: Deserialization error on received frame! Command: Calibration (calibration);
SCI: Rx Frame too short.
```

Ok

When upgrading to v1.x, the USB driver version is updated automatically. When downgrading manually to versions older than v1.x, you might need to install the older USB driver as well.

Flash the appropriate device software version onto the NXP microcontroller board by following the procedures in [Updating the Device Software](#).

**Figure 47: Flashing the Device Software**

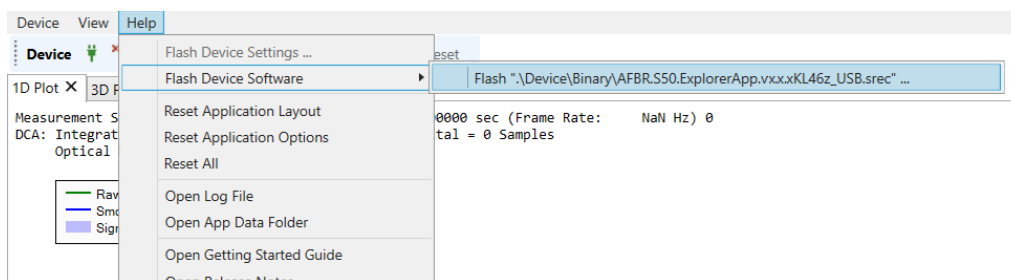

## A.3 SCI Error – No Communication to Sensor

Figure 48: SCI Error

SCI: Failed to open an USB connection!

If the issue persists, try the following steps:

- reset your device (push the reset button on the board or reconnect the USB cable)
- verify that the device is connected correctly to the "KL46Z" USB port (not the "OpenSDA" USB port)
- verify that the device is running the current device software version (i.e. re-flash the software via "Menu->Help->Flash Device Software...")

Ok

In principle, this message can have multiple reasons. Most likely, the USB cable was plugged into the openSDA (see [Figure 7](#)) instead of the KL46Z USB port. Another reason can be that the device software is corrupted and must be flashed again (see [Section A.2, Different Versions of Explorer and Controller Board](#)). Because this error indicates a serial communication issue, it is also possible that your sensor is defective or the USB cable might need to be replaced.

## A.4 Xtalk Calibration – 3D Plot Is Not Visible

Figure 49: Xtalk Calibration

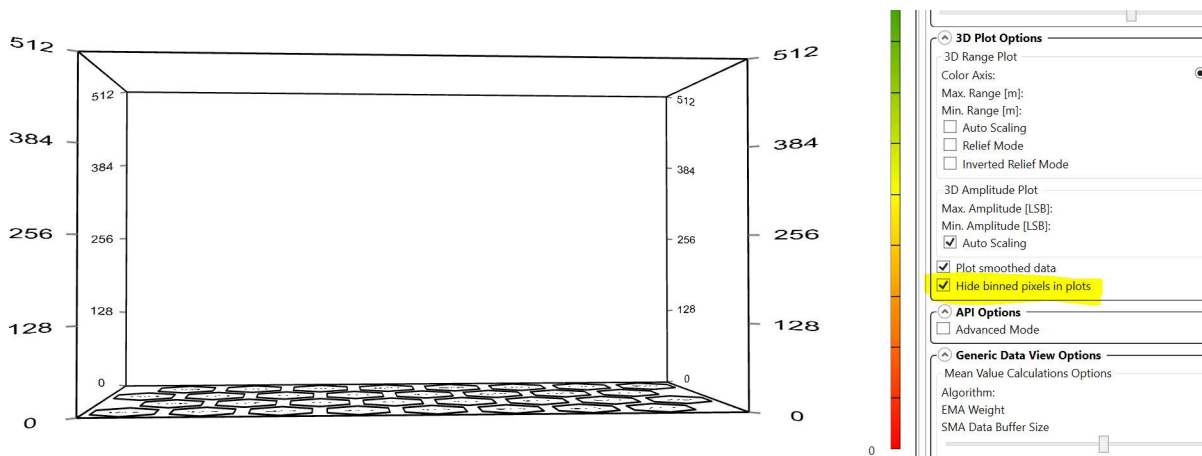

If there is an empty amplitude chart, it might be that the check box for **Hide binned pixels in plots** is still enabled. To see low amplitudes while performing the Xtalk calibration make sure this option is not selected.

## A.5 Xtalk Calibration – Amplitude Error

Figure 50: Amplitude Error Message

```

Message Log
Device @ 18.612528 s
Xtalk Calibration: maximum amplitude exceedance!
One or more crosstalk vector components are exceeding the maximum amplitude limit.
In order to perform a crosstalk calibration, the receiver lens must not receive any signal from the sender lens, e.g. by covering the sensor or targeting to infinity.
Please verify your setup and calibration results and repeat...
Device @ 18.613680 s
Crosstalk Vector Calibration sequence failed to execute, error code: -112 (Crosstalk Vector Amplitude Too High)
SCI: Sending Tx Frame (cmd: MeasurementCalibration (0x18)) failed: device responded with NAK
Error code: -112 (Crosstalk Vector Amplitude Too High)
Device @ 18.658784 s
received command 0x18, decoding/execution failed!
command error code: -112 (Crosstalk Vector Amplitude Too High)
Device @ 18.659104 s
Scheduler: task (name: "Handle SCI Command" - prio 6) execution failed, error code: -112 (Crosstalk Vector Amplitude Too High)
Ok

```



This error appears when the amplitude exceeds the default maximum amplitude of 20 LSB while running the Xtalk calibration. For Step 2 and Step 3 of the Xtalk calibration (necessary to compensate cover glasses), it might be necessary to increase this limit. This can be done in the **Calibration Sequence Setup** section at the bottom of **API** tab.

**Figure 51: Calibration Sequence Setup Section**

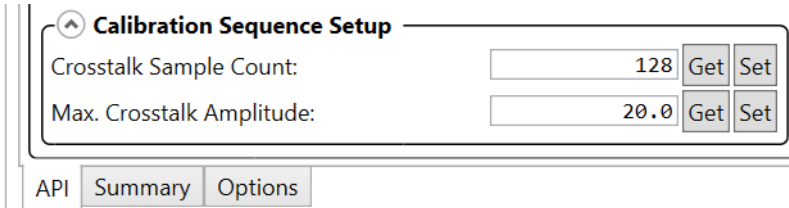

Calibration Sequence Setup

Crosstalk Sample Count:	<input type="text" value="128"/>	Get	Set
Max. Crosstalk Amplitude:	<input type="text" value="20.0"/>	Get	Set

API Summary Options

If it is not visible, you might need to enable the **Advanced Mode** in the **Options** tab.

## Revision History

### **AFBR-S50-EK-UG103; March 30, 2023**

- Updated for new release.

### **AFBR-S50-EK-UG102; November 30, 2020**

- Updated for new release.

### **AFBR-S50-EK-UG101; May 6, 2020**

- Updated for new release.

### **AFBR-S50-EK-UG100; December 6, 2019**

- Initial release.

