

REVISIONS					
P.	LTN	DESCRIPTION	DATE	OWN	APVD
1		PRELIMINARY DRAWING	17SEP2019	LL	DZ
2		ADD PACKAGE	22OCT2019	LL	DZ
3		UPDATE THE PACKAGE AND CAP	29NOV2019	LL	DZ
4		ADD NEW PINS 2-X,3-X	09DEC2019	LL	DZ

- NOTES:
- MATERIALS:  
 PLASTICS: HIGH TEMPERATURE THERMOPLASTIC UL94V-0, COLOR: BLACK.  
 SHELL: STAINLESS  
 CONTACT: COPPER ALLOY  
 DUST CAP: STAINLESS.
  - FINISH:  
 TERMINAL: CONTACT AREA: SELECTED GOLD PLATING, SEE TABLE.  
 SOLDER AREA: MATTE TIN PLATING 100u".  
 UNDER PLATING: NICKEL PLATING 50u" MIN OVER ALL.  
 SHELL: UNDER PLATING: ELECTROLESS NICKEL PLATING 50u" MIN OVERALL.
  - HALOGEN REQUIREMENT MEET CODE 2: LOW BR/CL AS DEFINED IN TEC-138-702.
  - TE CONNECTIVITY LOGO MARKED IN APPROXIMATE AREA SHOWN.
  - PART NUMBER AND DATE CODE MARKED IN APPROXIMATE AREA SHOWN.
  - TAPE AND REEL PACKAGED FOR PICK AND PLACE SMT PROCESSING.  
 SEE FIGURE 1. POCKET TAPE WIDTH = 72MM.

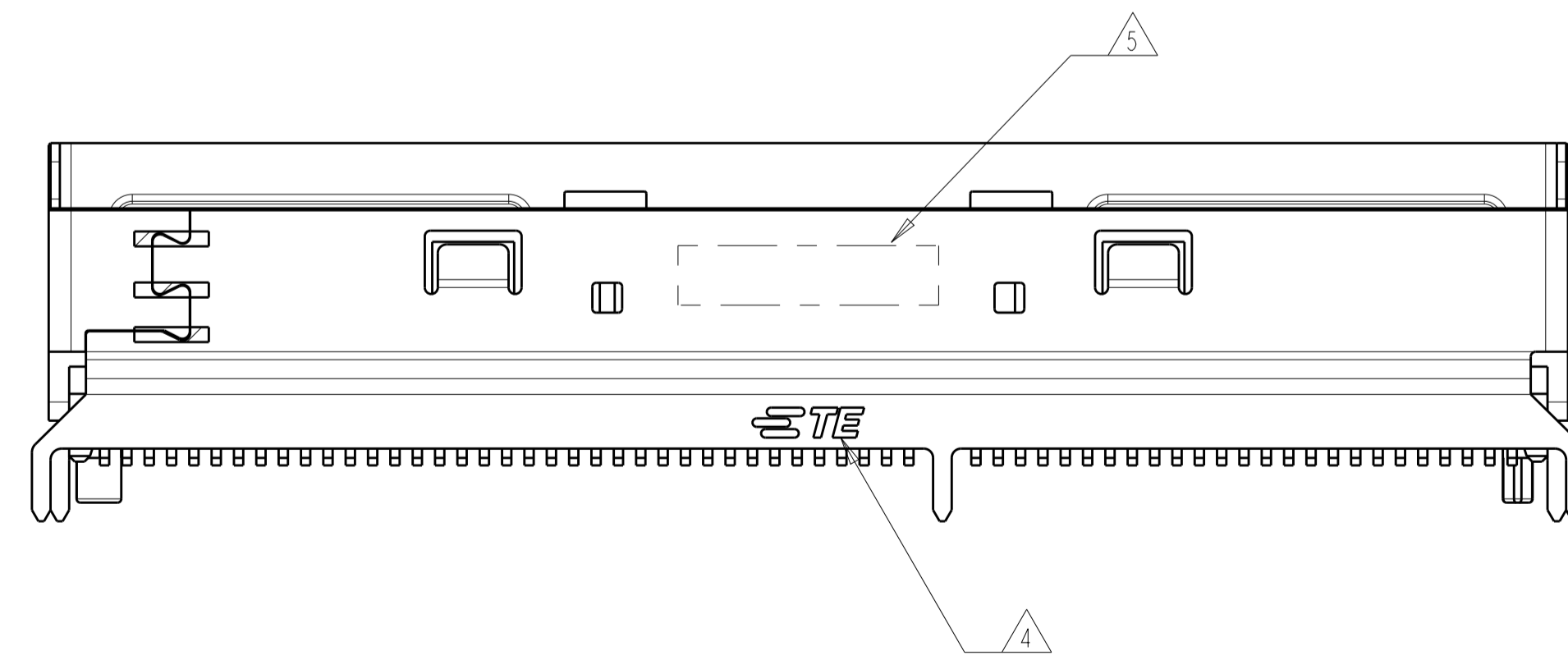
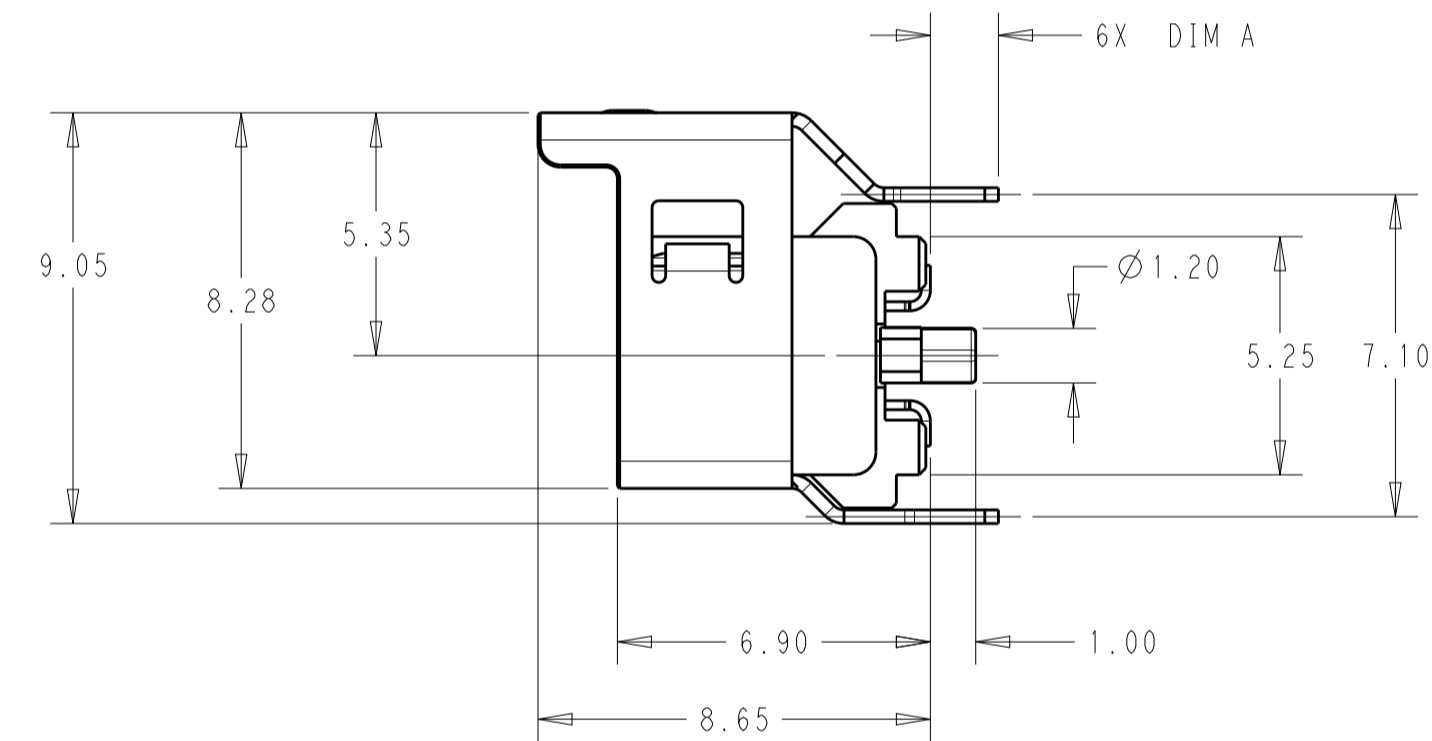
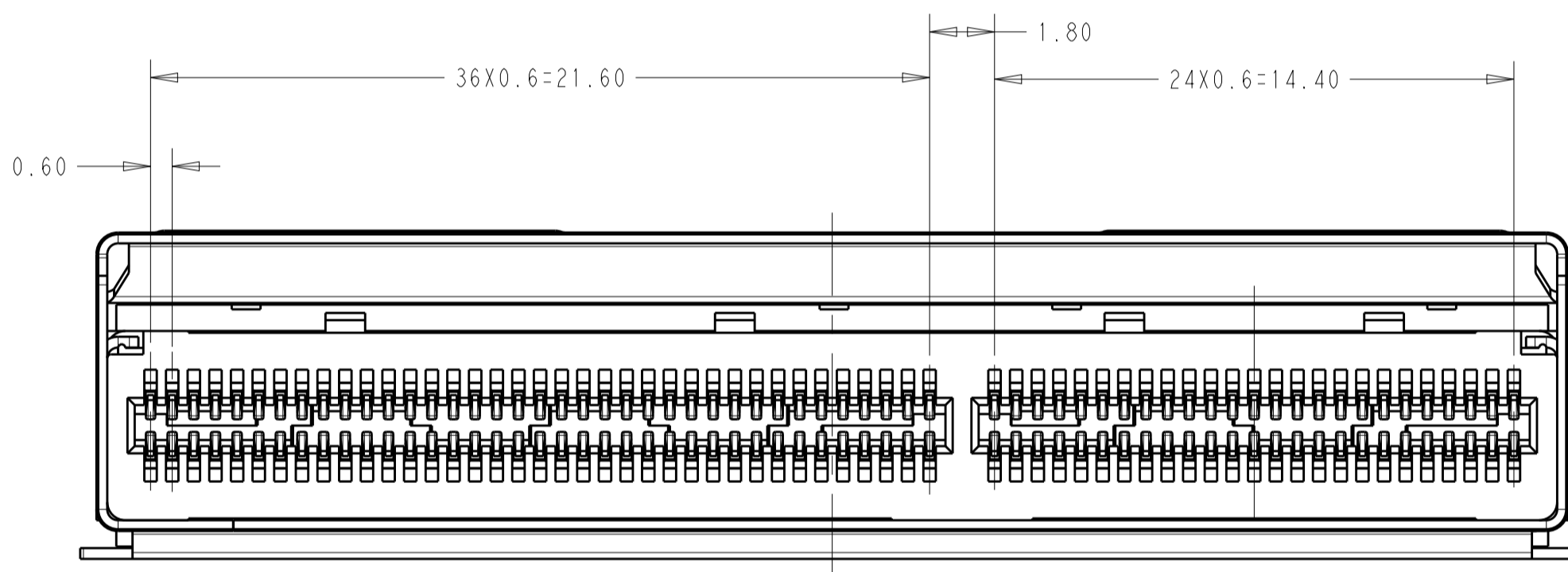
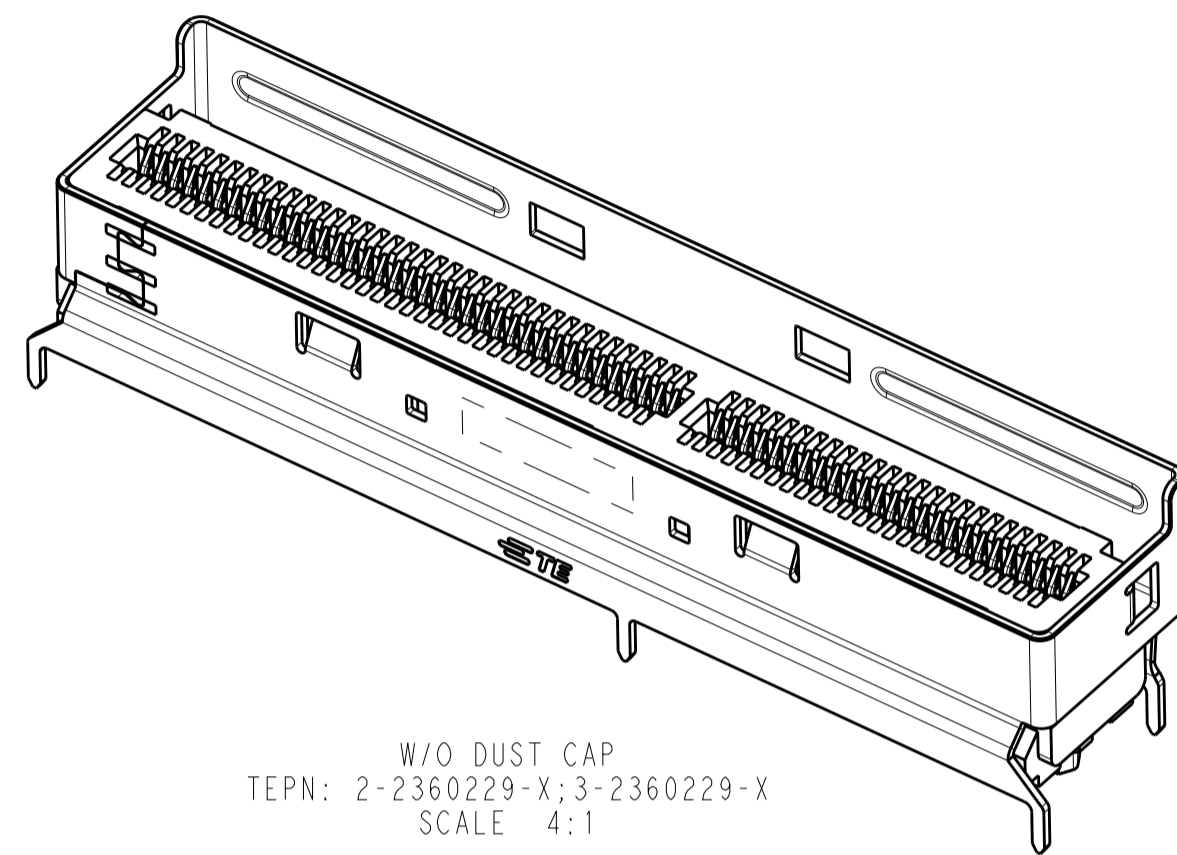
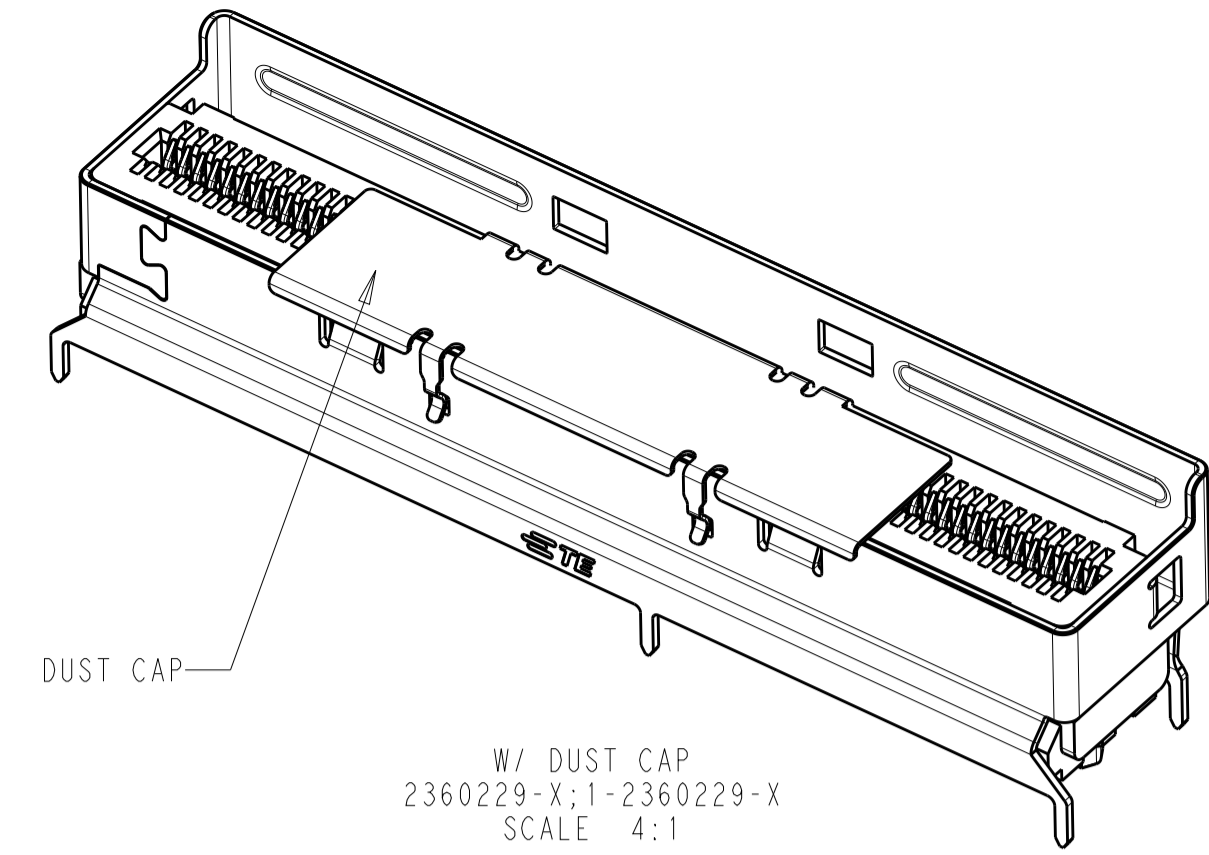
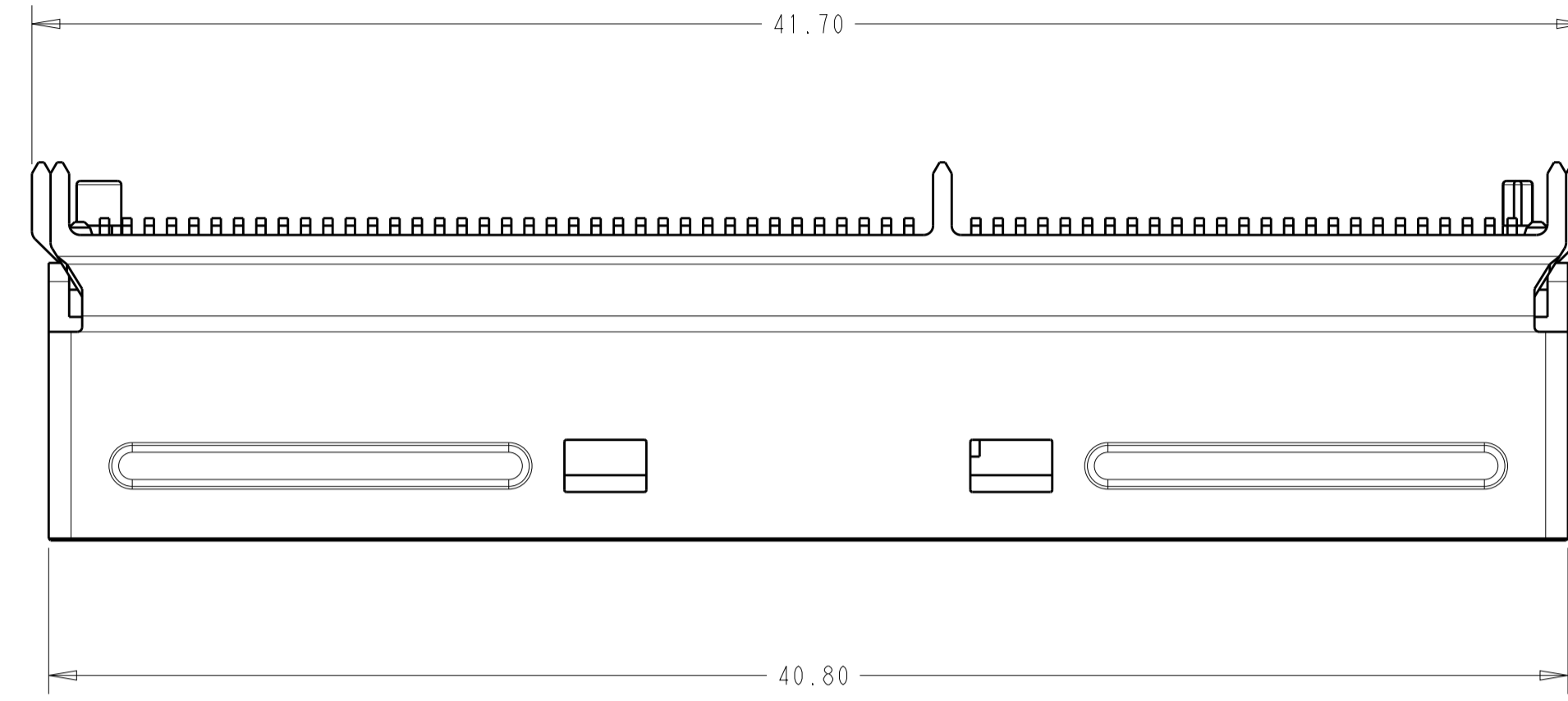

PROPOSED DESIGN  
 PRODUCT NUMBER WILL BE  
 ASSIGNED WHEN RELEASED  
 DESIGN IS SUBJECT TO  
 CHANGE WITHOUT NOTICE

QUANTITY /CARTON	QUANTITY /REEL	CAP OPTION	OPTIONS	CONTACT FINISH	DIM A	PART NUMBER
450PCS	150PCS	W/O DUST CAP	STANDARD CONSTRUCTION	30u" GOLD	4.20MM	3-2360229-8
					3.00MM	3-2360229-7
					2.20MM	3-2360229-6
			NO RESONANCE DAMPING	15u" GOLD	4.20MM	3-2360229-4
					3.00MM	3-2360229-3
					2.20MM	3-2360229-2
		W/ DUST CAP	STANDARD CONSTRUCTION	30u" GOLD	4.20MM	2-2360229-8
					2.20MM	2-2360229-6
					1.50MM	2-2360229-5
			NO RESONANCE DAMPING	15u" GOLD	4.20MM	2-2360229-4
					3.00MM	2-2360229-3
					2.20MM	2-2360229-2
450PCS	150PCS	W/O DUST CAP	STANDARD CONSTRUCTION	30u" GOLD	4.20MM	1-2360229-8
					3.00MM	1-2360229-7
					2.20MM	1-2360229-6
			NO RESONANCE DAMPING	15u" GOLD	4.20MM	1-2360229-4
					3.00MM	1-2360229-3
					2.20MM	1-2360229-2
		W/ DUST CAP	STANDARD CONSTRUCTION	30u" GOLD	4.20MM	2360229-8
					3.00MM	2360229-7
					2.20MM	2360229-6
			NO RESONANCE DAMPING	15u" GOLD	4.20MM	2360229-4
					3.00MM	2360229-3
					2.20MM	2360229-2
					1.50MM	2360229-1

THIS DRAWING IS A CONTROLLED DOCUMENT.

OWN: LEO LI 17SEP2019  
 CHK: DAVID ZHANG 17SEP2019  
 APVD: DAVID ZHANG 17SEP2019

TOLERANCES UNLESS OTHERWISE SPECIFIED:  
 0 PLC ±  
 1 PLC ±0.20  
 2 PLC ±0.15  
 3 PLC ±  
 4 PLC ±  
 ANGLES ±

FINISH: SEE NOTES

WEIGHT: -  
 CUSTOMER DRAWING

NAME: LOW PROFILE SLIM SAS RECEPTACLE VERTICAL X16, 124P

SIZE: A1  
 CAGE CODE: 00779  
 DRAWING NO: 2360229

RESTRICTED TO: -

SCALE: 6:1 SHEET 1 OF 3 REV 4

REVISIONS				
P.	LTN	DESCRIPTION	DATE	APP'D
		SEE SHEET 1		

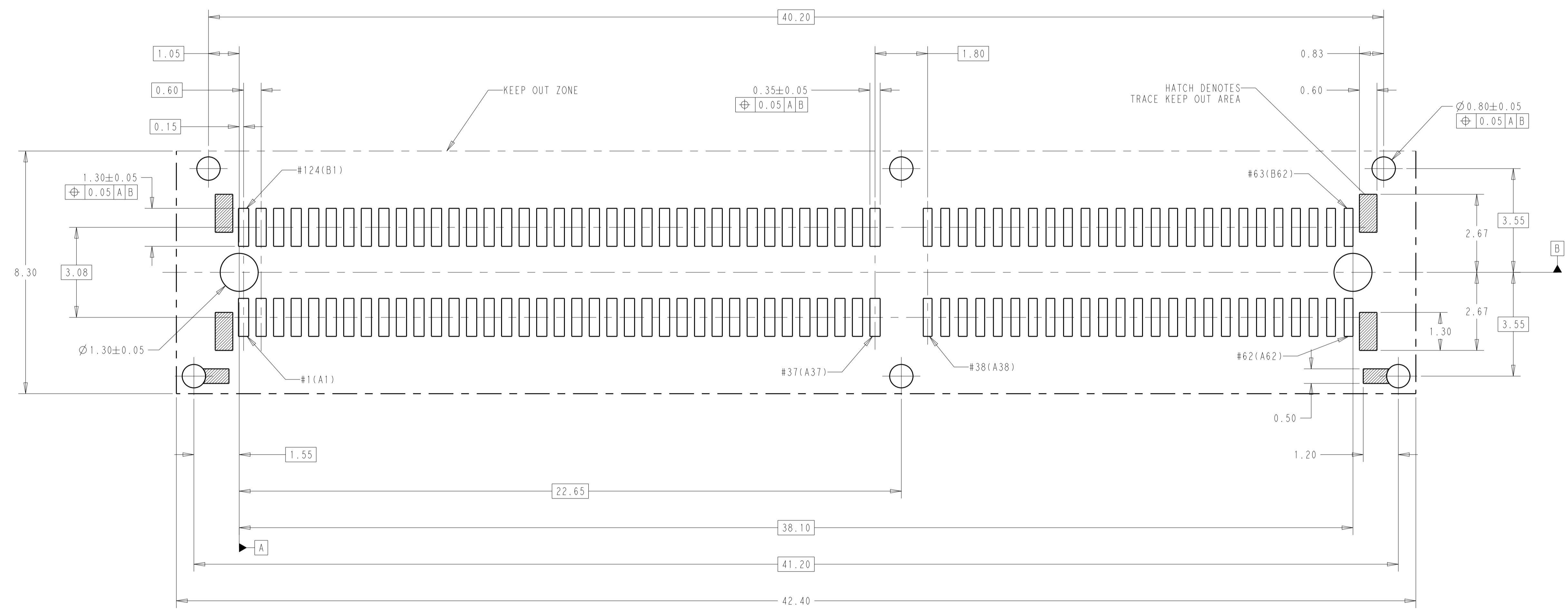

RECOMMENDED PCB LAYOUT  
 GENERAL TOLERANCE: ±0.05  
 SCALE 12:1

PROPOSED DESIGN  
 PRODUCT NUMBER WILL BE  
 ASSIGNED WHEN RELEASED  
 DESIGN IS SUBJECT TO  
 CHANGE WITHOUT NOTICE

THIS DRAWING IS A CONTROLLED DOCUMENT.		DWN: LEO LI 17SEP2019	TE Connectivity
DIMENSIONS: mm		CHK: DAVID ZHANG 17SEP2019	
TOLERANCES UNLESS OTHERWISE SPECIFIED: 0 PLC ±0.20 1 PLC ±0.15 2 PLC ±0.15 3 PLC ±0.15 4 PLC ±0.15 ANGLES ±0.15		APVD: DAVID ZHANG 17SEP2019	NAME: LOW PROFILE SLIM SAS RECEPTACLE VERTICAL X16, 124P
MATERIAL: SEE NOTES		FINISH: SEE NOTES	PRODUCT SPEC: 108-60134
		WEIGHT: -	APPLICATION SPEC: -
		CUSTOMER DRAWING	SIZE: A1 CAGE CODE: 00779 DRAWING NO: 2360229
		SCALE: 6:1	RESTRICTED TO: -
		SHEET: 2 OF 3	REV: 4

REVISIONS				
P.	LTN	DESCRIPTION	DATE	APVD
-	-	SEE SHEET 1	-	-

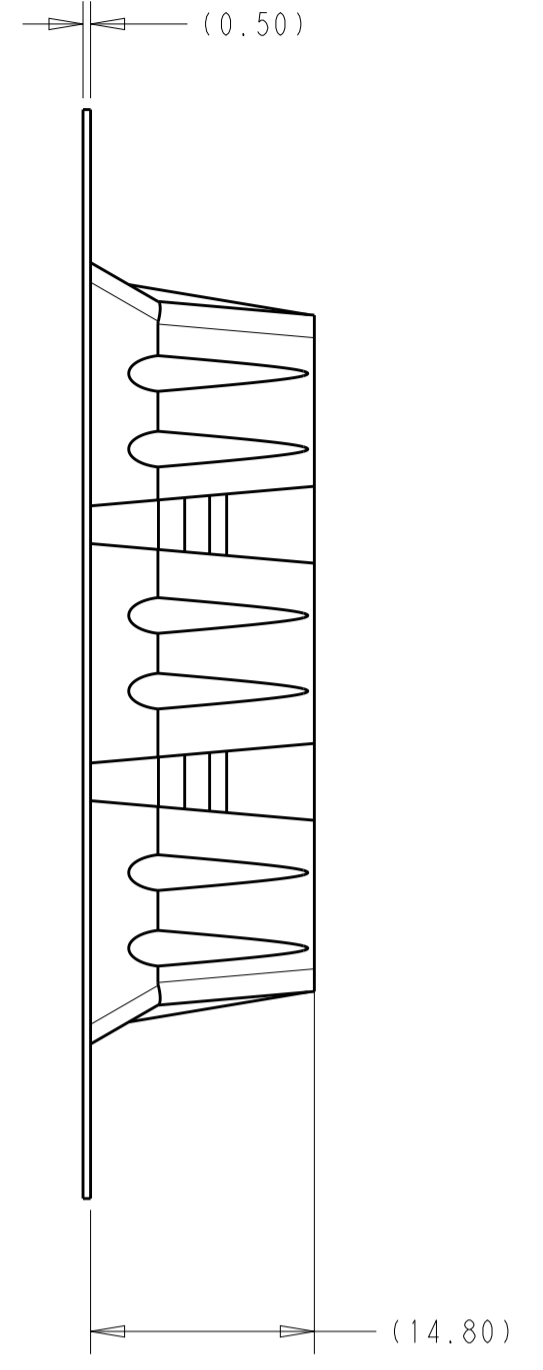
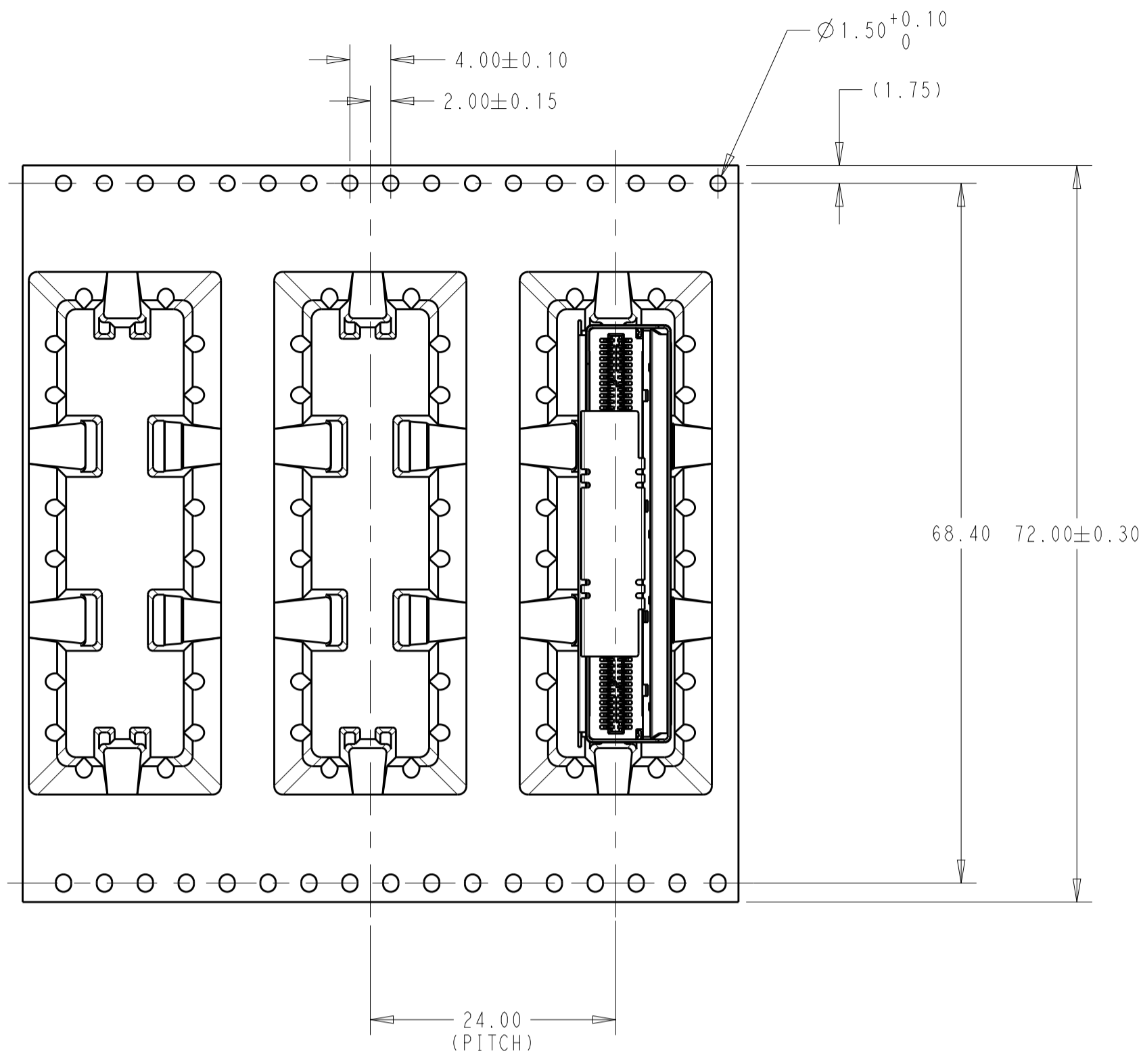

PROPOSED DESIGN  
 PRODUCT NUMBER WILL BE  
 ASSIGNED WHEN RELEASED  
 DESIGN IS SUBJECT TO  
 CHANGE WITHOUT NOTICE

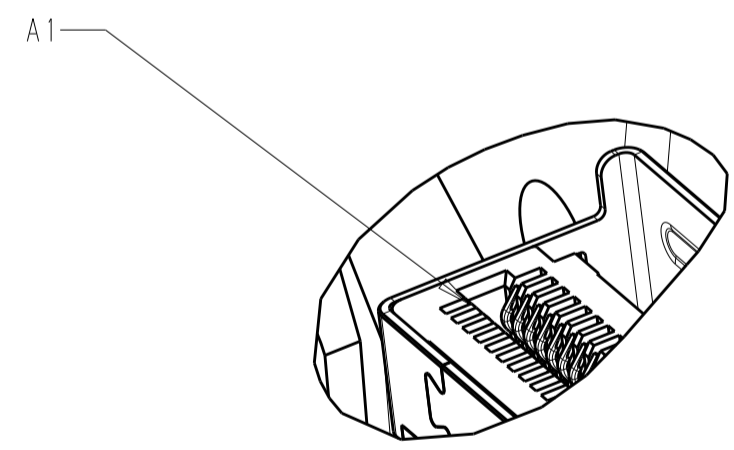
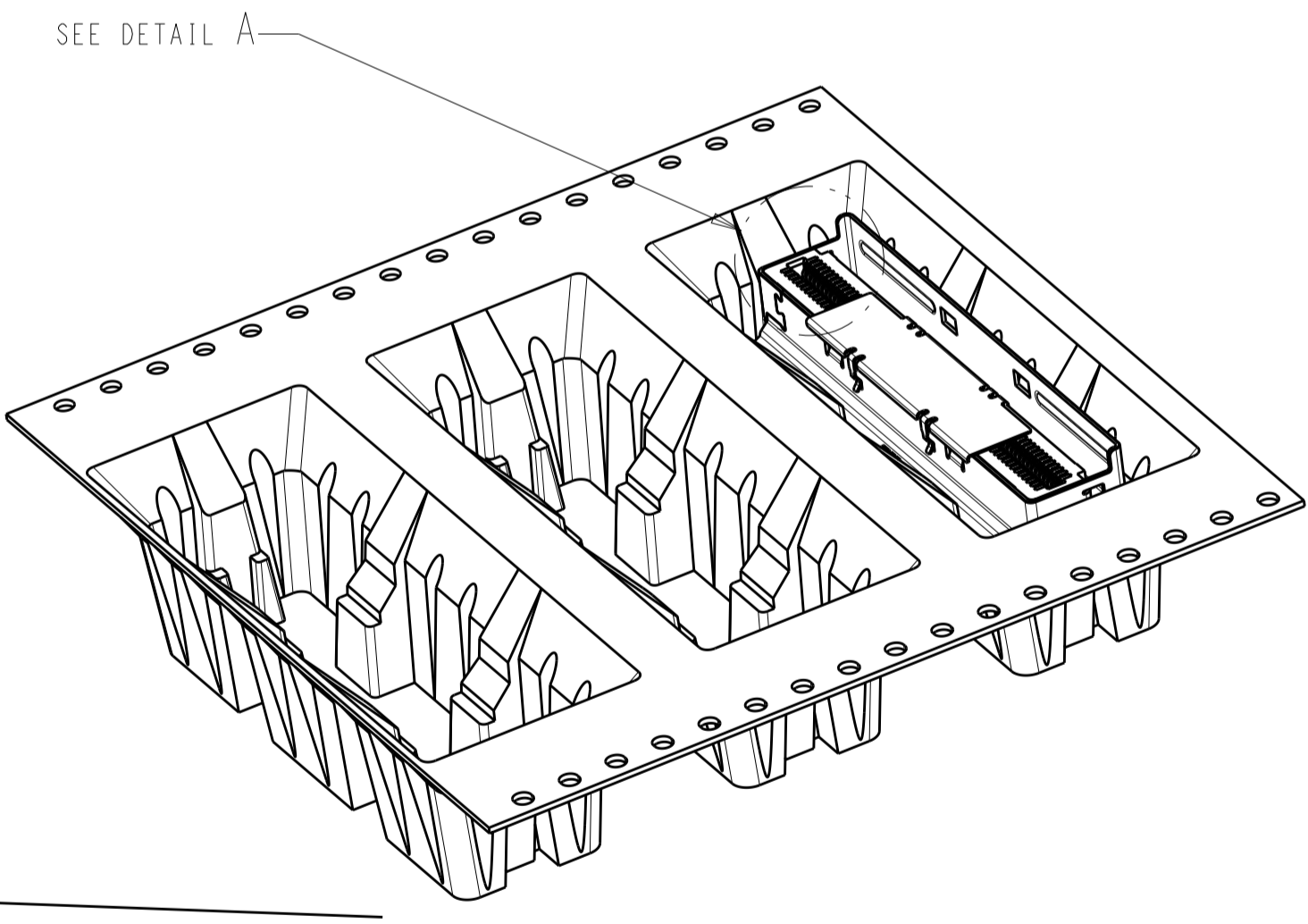

DETAIL A  
 SCALE 5:1

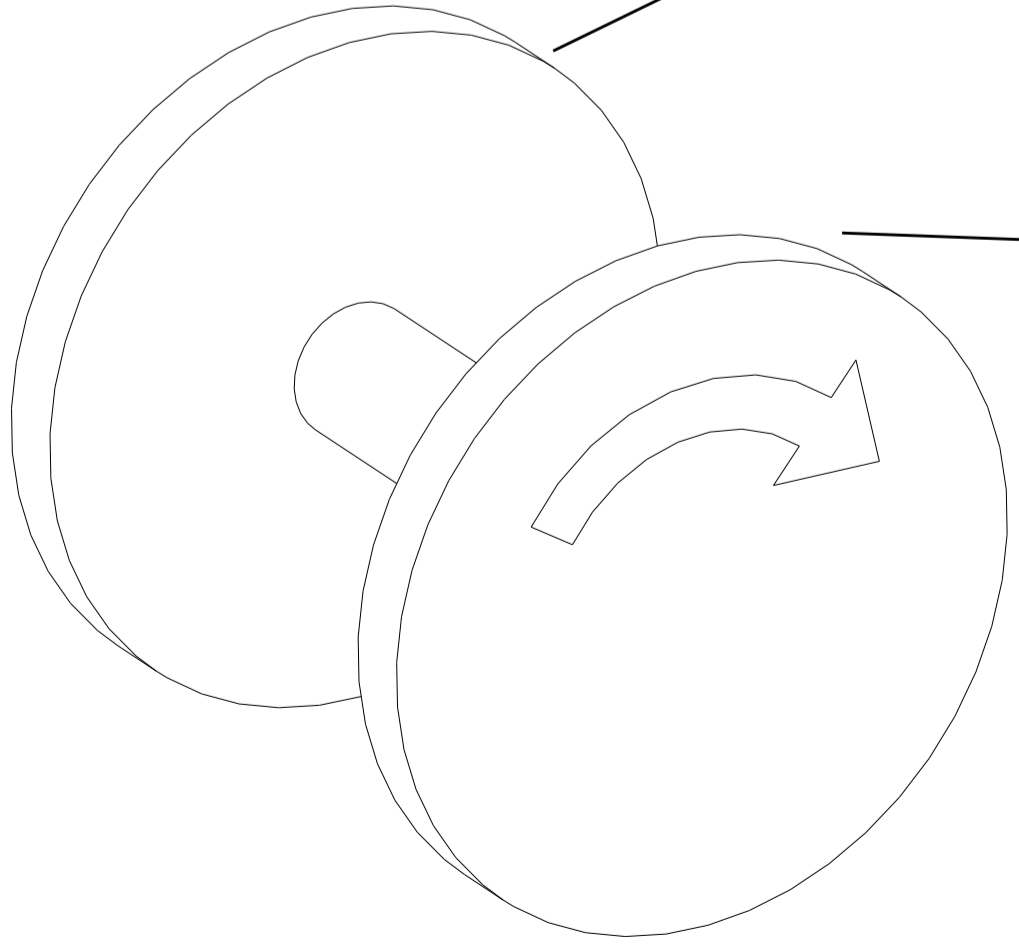

△ FIGURE 1  
 DIRECTION OFF TOP OF REEL  
 FOR USER UNREELING  
 SCALE 2:1

THIS DRAWING IS A CONTROLLED DOCUMENT.		DWN: LEO LI 17SEP2019	
DIMENSIONS: mm		CHK: DAVID ZHANG 17SEP2019	
TOLERANCES UNLESS OTHERWISE SPECIFIED:		APVD: DAVID ZHANG 17SEP2019	NAME: LOW PROFILE SLIM SAS RECEPTACLE VERTICAL X16, 124P
0 PLC ±0.20	1 PLC ±0.15	PRODUCT SPEC: 108-60134	SIZE: A
2 PLC ±0.15	3 PLC ±0.15	APPLICATION SPEC: -	CAGE CODE: 00779
4 PLC ±0.15	ANGLES ±0.15	WEIGHT: -	DRAWING NO: 2360229
MATERIAL: SEE NOTES	FINISH: SEE NOTES	CUSTOMER DRAWING	SCALE: 6:1
		SHEET 3 OF 3	REV 4