

PART NUMBER	PCS/REEL	REEL/BOX	PCS/BOX	REMARK
Connector:2171760001	600	6	3600	Assemble 2171766666 after reflow
Sealing O-RING:2171766666	600	6	3600	Assembled on 2171760001

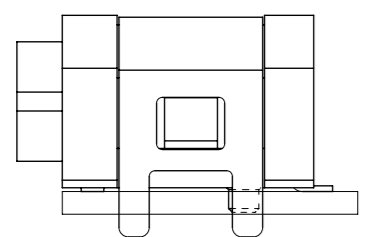

PART NO : 2171760001
Step 1:Connector Reflow soldering on PCB

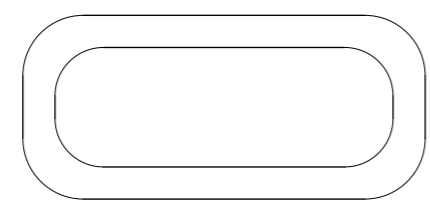

PART NO : 2171766666
Step 2:Find sealing O-ring in carton

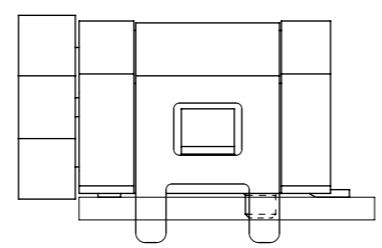

Schematic diagram
Step 3: assembled O-ring on connector

FUNCTIONAL SYMBOLS	THIS DRAWING CONTAINS INFORMATION THAT IS PROPRIETARY TO MOLEX ELECTRONIC TECHNOLOGIES, LLC AND SHOULD NOT BE USED WITHOUT WRITTEN PERMISSION		CURRENT REV DESC:		molex		
	△A = 0	mm	SCALE 1:1				
DIVISIONAL SYMBOLS	GENERAL TOLERANCES (UNLESS SPECIFIED)		EC NO: 701020		PACKAGE FOR TYPE C 6PIN TOP MOUNT ADD PACKAGE OF O-RING.		
	△E = 0	ANGULAR TOL ± 3.0°		DRWN: FYANG05 2022/03/29			
	△F = 0	4 PLACES ±	3 PLACES ± 0.1	CHK'D: RLI09 2022/03/30			
		2 PLACES ± 0.2	2 PLACES ± 0.2	APPR: RLI09 2022/03/30			
		1 PLACE ± 0.3	1 PLACE ± 0.3	INITIAL REVISION:			
	0 PLACES ±	0 PLACES ±	DRWN: RZHANG 2021/02/17	DOCUMENT NUMBER 2171760001	DOC TYPE PDD	DOC PART PK1	REVISION C
	DRAFT WHERE APPLICABLE MUST REMAIN WITHIN DIMENSIONS	THIRD ANGLE PROJECTION	DRAWING A3-SIZE	SERIES 217176	MATERIAL NUMBER SEE CHART	CUSTOMER	SHEET NUMBER 1 OF 2

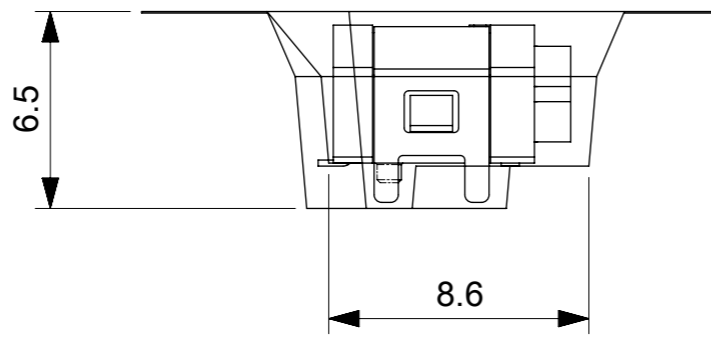
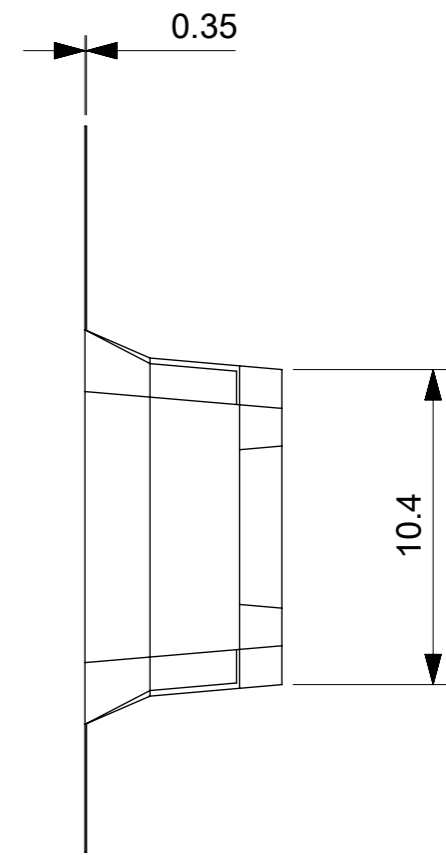
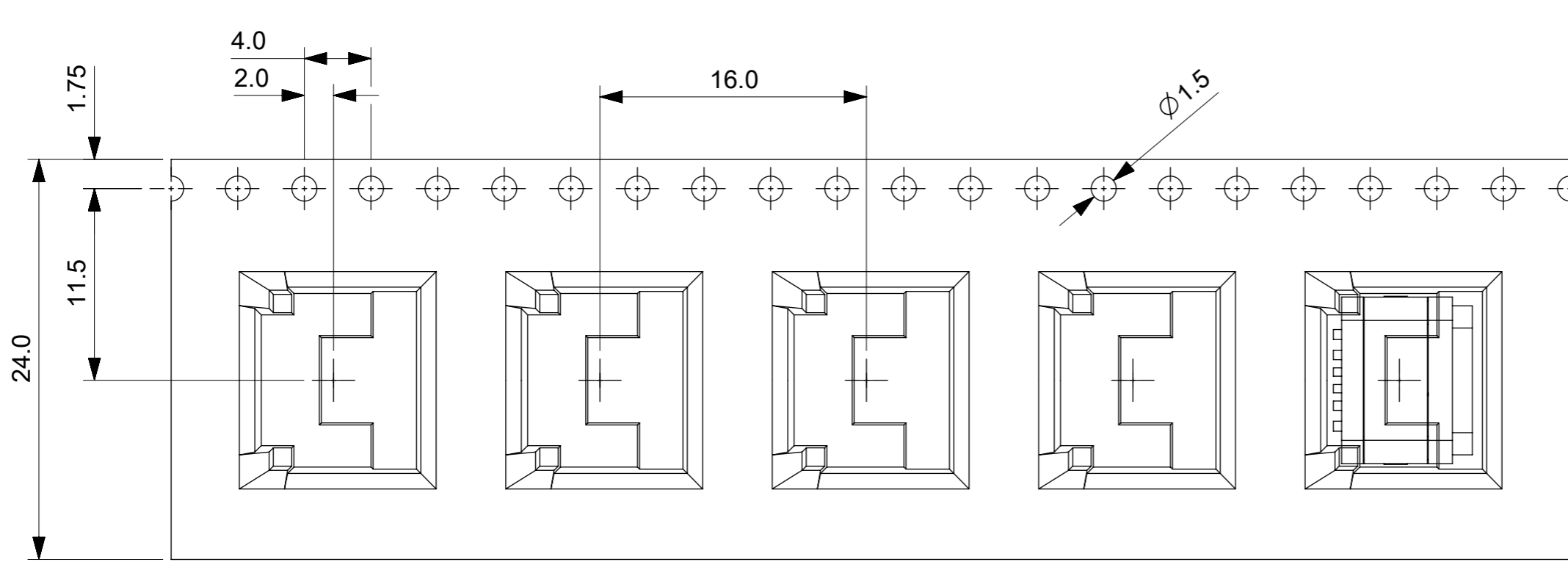

NOTES:
 1.MATERIAL:CARRIER:PET/TRANSPARENCY
 2.THICKNESS:0.35±0.05MM

FUNCTIONAL SYMBOLS	THIS DRAWING CONTAINS INFORMATION THAT IS PROPRIETARY TO MOLEX ELECTRONIC TECHNOLOGIES, LLC AND SHOULD NOT BE USED WITHOUT WRITTEN PERMISSION		CURRENT REV DESC:			molex		
	△/A = 0	mm						
DIVISIONAL SYMBOLS	GENERAL TOLERANCES (UNLESS SPECIFIED)		EC NO: 701020 DRWN: FYANG05 2022/03/29 CHK'D: RLI09 2022/03/30 APPR: RLI09 2022/03/30 INITIAL REVISION: DRWN: RZHANG 2021/02/17 APPR: AYIN 2021/02/22			PACKAGING DESIGN DRAWING		
	△/E = 0	ANGULAR TOL ± 3.0 °				DOCUMENT NUMBER		
	△/F = 0	4 PLACES ±				2171760001		
		3 PLACES ± 0.1				DOC TYPE	DOC PART	REVISION
		2 PLACES ± 0.2				PDD	PK1	C
	1 PLACE ± 0.3	MATERIAL NUMBER			CUSTOMER			
	0 PLACES ±	SEE CHART			SHEET NUMBER			
DRAFT WHERE APPLICABLE MUST REMAIN WITHIN DIMENSIONS		THIRD ANGLE PROJECTION	DRAWING	SERIES	MATERIAL NUMBER			CUSTOMER
			A3-SIZE	217176	SEE CHART			2 OF 2