

LOC	DIST	P	F	ZONE	LTR	DESCRIPTION	DATE	APPD
BD	50					0 RLSE NPR 4509, WAS 89-1001-4-1	12/23/92	-
						REV PER EC 0020-13-93		
						A REV PER EC 0020-1350-94	01/09/95	SM
						B PER EC 0640-180-98	07 APR 99	JS

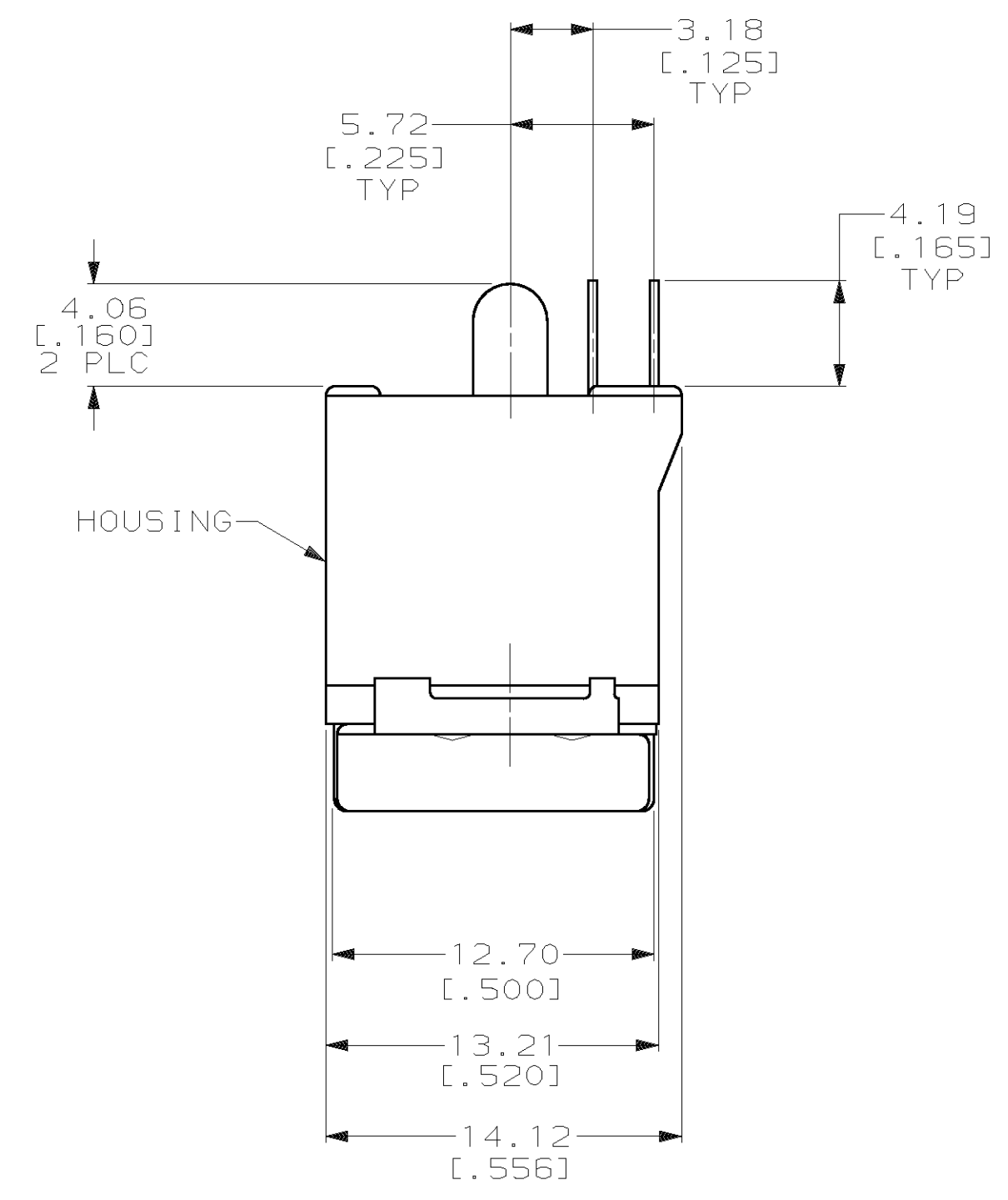

- PREFIX AND SUFFIX NUMBERS MUST MATCH THOSE ON PLUG ASSEMBLY FOR PARTS TO MATE.
- POLYESTER, FLAME RETARDANT, UL 94V-0 RATED, GLASS FILLED, BLACK.
- 0.76µm [.000030] MIN TIN-LEAD OVER 2.54µm [.000100] MIN COPPER.
- 1.27µm [.000050] MIN GOLD ON MATING SURFACE FOR A LENGTH OF 2.54 [.100] MIN, 3.81µm [.000150] MIN TIN-LEAD ON OPPOSITE END FOR A LENGTH OF 3.81 [.150] MIN, BOTH OVER 1.27µm [.000050] MIN NICKEL ON ENTIRE CONTACT.

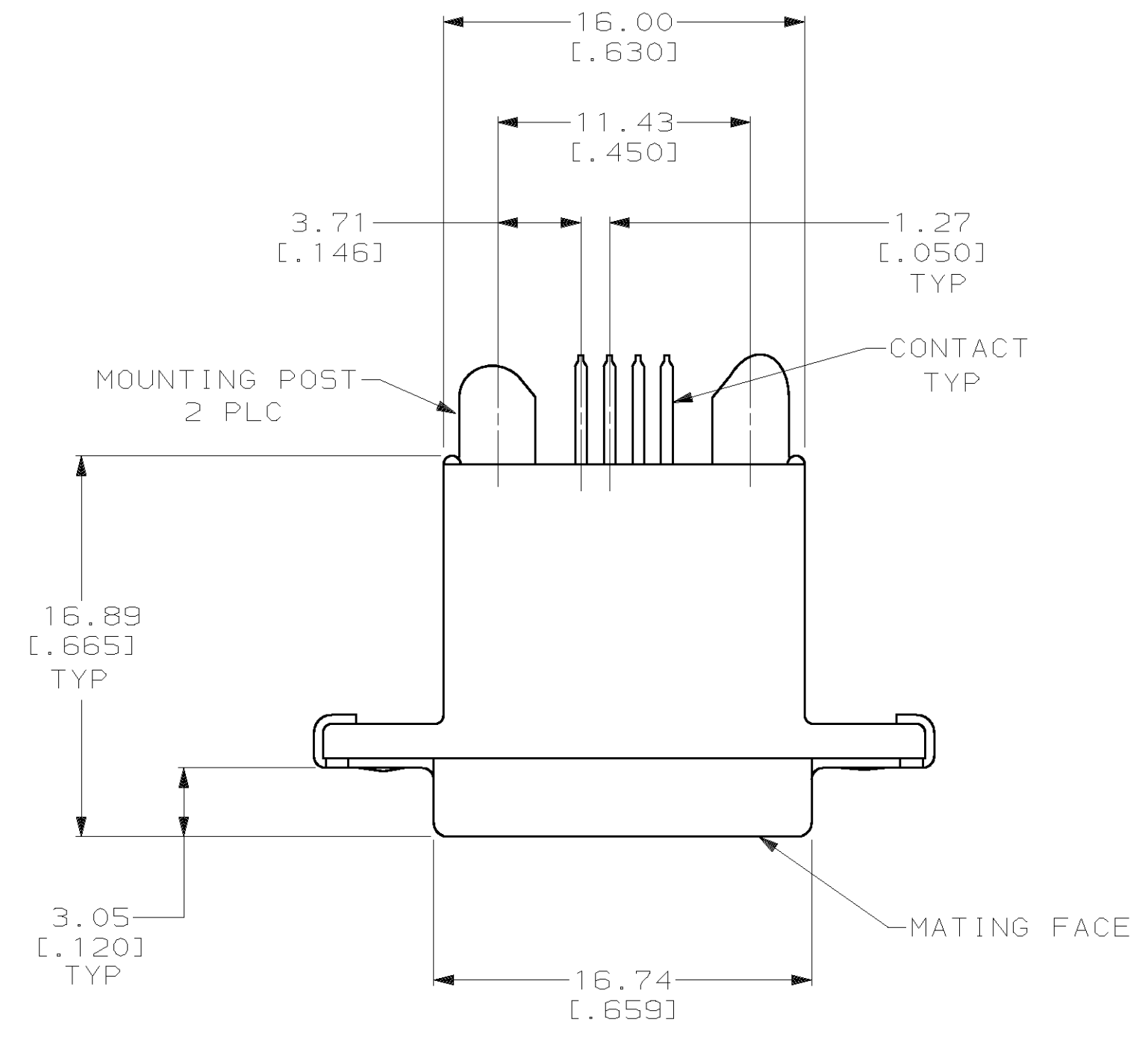
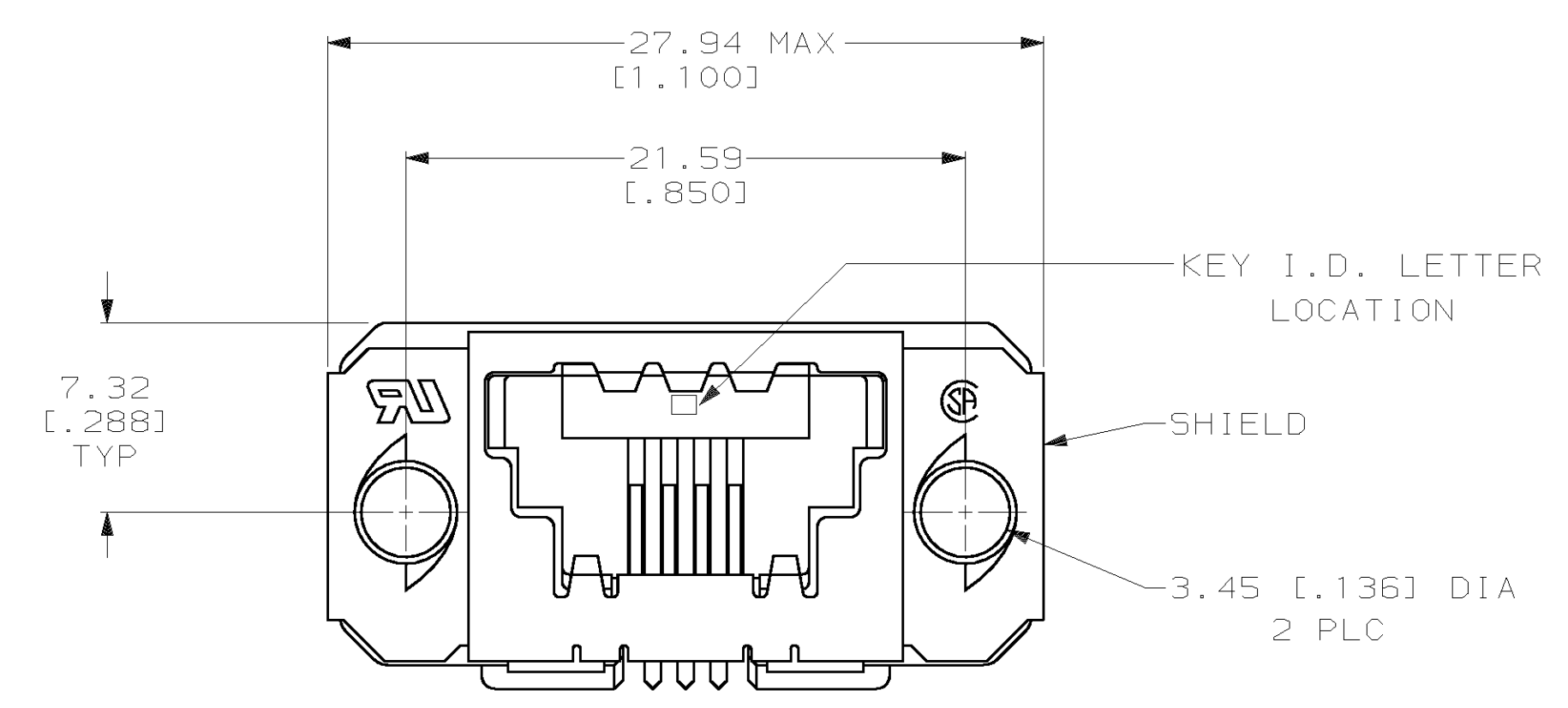

DO NOT SCALE PRINT. UNLESS SPECIFIED DIMENSIONS IN mm [INCHES]		DR 12/23/92 C.OBERMAN	D 4-943213-1	
TOLERANCES ON: 2 PLC DEC ± 0.38 [.015] 3 PLC DEC ± - ANGLES ± -		CHK 12-23-92 W.LENKER	KEY I.D. LETTER PART NO	
MATERIAL HOUSING: SHIELD: BRASS CONTACT: PHOSPHOR BRONZE		APPD 12-23-92 J.PRITULSKY	AMP Incorporated Harrisburg, PA 17105-3508	
FINISH SHIELD: CONTACT:		APPD 12-23-92 C.HAMMAKER	NAME RECEPTACLE ASSEMBLY, 4 POSN, TOP ENTRY, FOR .093 PC BOARD, SDL	
PRODUCT SPEC 108-2047		APPLICATION SPEC 114-2081	SIZE D	CAGE CODE 00779
WEIGHT -		SCALE 4:1	DRAWING NO C-943213	SHEET 1 OF 1

THIS DRAWING IS A CONTROLLED DOCUMENT FOR AMP INCORPORATED. IT IS SUBJECT TO CHANGE AND THE CONTROLLING ENGINEERING ORGANIZATION SHOULD BE CONTACTED FOR THE LATEST REVISION.