



## Main

|                                    |                     |
|------------------------------------|---------------------|
| Range of Product                   | Harmony XVU         |
| Product or Component Type          | Modular tower light |
| Beacon or indicator bank unit type | Sound unit          |
| Mounting diameter                  | 2.36 in (60 mm)     |
| Component name                     | XVU                 |
| Housing Colour                     | Black               |

## Complementary

|                                |   |
|--------------------------------|---|
| Signalling type                | Adjustable vocal sound  |
| Material                       | PBT (polybutylene terephthalate) V-0 UL 94<br>ABS (acrylonitrile butadiene-styrene) V-0 UL 94 |
| Localisation on device         | AC/DC adapter   |
| Assembly style                 | Customer assembly   |
| [Us] rated supply voltage      | 24 V AC/DC  |
| Maximum power dissipation in W | 5.55 W  |
| Acoustic level                 | 86 dB 1 m   |
| Sound frequency                | 20 Hz...20 KHz  |
| Current consumption            | <= 400 mA 24 V AC/DC<br><= 135 mA 100...240 V AC  |
| Length                         | 6.10 in (155 mm)  |
| Net Weight                     | 0.48 lb(US) (0.219 kg)  |

## Environment

|                                       |                            |
|---------------------------------------|----------------------------|
| Product Certifications                | UL<br>CSA<br>CE            |
| Ambient Air Temperature for Storage   | -40...158 °F (-40...70 °C) |
| Ambient air temperature for operation | -4...122 °F (-20...50 °C)  |
| IP degree of protection               | IP54                       |

## Ordering and shipping details

|                       |                          |
|-----------------------|--------------------------|
| Category              | 22618 - XVU TOWER LIGHTS |
| Discount Schedule     | XV                       |
| GTIN                  | 3606480555893            |
| Nbr. of units in pkg. | 1                        |
| Package weight(Lbs)   | 13.09 oz (371 g)         |
| Returnability         | Yes                      |
| Country of origin     | ID                       |

## Packing Units

|                              |                          |
|------------------------------|--------------------------|
| Unit Type of Package 1       | PCE                      |
| Package 1 Height             | 3.54 in (9 cm)           |
| Package 1 width              | 3.74 in (9.5 cm)         |
| Package 1 Length             | 10.43 in (26.5 cm)       |
| Unit Type of Package 2       | S04                      |
| Number of Units in Package 2 | 24                       |
| Package 2 Weight             | 22.23 lb(US) (10.084 kg) |
| Package 2 Height             | 11.81 in (30 cm)         |
| Package 2 width              | 15.75 in (40 cm)         |
| Package 2 Length             | 23.62 in (60 cm)         |

## Offer Sustainability

|                            |   |
|----------------------------|---|
| Sustainable offer status   | Green Premium product   |
| California proposition 65  | WARNING: This product can expose you to chemicals including: Lead and lead compounds, which is known to the State of California to cause cancer and birth defects or other reproductive harm. For more information go to <a href="http://www.P65Warnings.ca.gov">www.P65Warnings.ca.gov</a> |
| REACH Regulation           | <a href="#">REACH Declaration</a>   |
| EU RoHS Directive          | Pro-active compliance (Product out of EU RoHS legal scope) <a href="#">EU RoHS Declaration</a>  |
| Mercury free               | Yes   |
| RoHS exemption information | <a href="#">Yes</a>   |
| China RoHS Regulation      | <a href="#">China RoHS Declaration</a>  |
| Environmental Disclosure   | <a href="#">Product Environmental Profile</a>   |
| Circularity Profile        | <a href="#">End Of Life Information</a>   |

## Dimensions

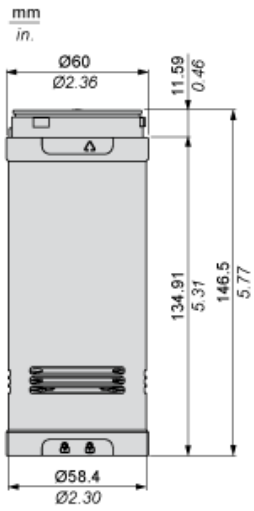

## Modular Tower Lights Mounting

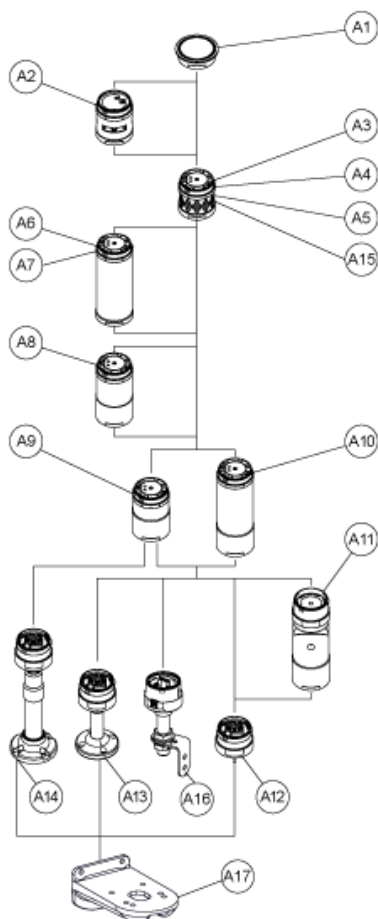

| Drawing  | Part number          | Part name                    |
|----------|----------------------|------------------------------|
| A1       | -                    | Top cover                    |
| -        | Top cover (Silver)   |                              |
| A2       | XVUC9S               | Buzzer unit                  |
| XVUC9SQ  | Buzzer unit (Silver) |                              |
| A3       | XVUC23               | Green LED unit               |
| XVUC24   | Red LED unit         |                              |
| XVUC25   | Orange LED unit      |                              |
| XVUC26   | Blue LED unit        |                              |
| XVUC27   | White LED unit       |                              |
| XVUC28   | Yellow LED unit      |                              |
| A4       | XVUC29               | Multi-LED unit               |
| A5       | XVUC29P              | Multi-LED unit, Pulse signal |
| A6       | XVUC9V               | Sound unit                   |
| A7       | XVUC9VP              | Sound unit, Pulse signal     |
| A8       | XVUC020              | Extender                     |
| XVUC020Q | Extender (Silver)    |                              |
| A9       | XVUC21B              | DC body                      |

| Drawing   | Part number                                    | Part name   |
|-----------|--|---|
| XVUC21BQ  | DC body (Silver)                               |   |
| A10       | XVUC21M  | AC body NPN   |
| XVUC21MP  | AC body PNP                                    |   |
| XVUC21MQP | AC body PNP (Silver)                           |   |
| A11       | XVUZ06   | Flexible option                                       |
| A12       | XVUZ01   | Fixing Unit - Direct mounting (3 pins)                |
| XVUZ01Q   | Fixing Unit - Direct mounting (Silver,3 pins)  |   |
| XVUZ03    | Fixing Unit - Direct mounting (2 pins)         |   |
| XVUZ04    | Fixing Unit - Direct mounting (4 pins)         |   |
| A13       | XVUZ02   | Fixing Unit - Plate with Pole (100 mm)                |
| XVUZ02Q   | Fixing Unit - Plate with Pole (100 mm, Silver) |   |
| XVUZ400   | Fixing Unit - Plate with Pole (400 mm)         |   |
| XVUZ800   | Fixing Unit - Plate with Pole (800 mm)         |   |
| A14       | XVUZ05   | Fixing Unit - Plate with adjustment pole (100-385 mm) |
| A15       | XVUC43   | Green LED unit, Flash                                 |
| XVUC44    | Red LED unit, Flash                            |   |
| XVUC45    | Orange LED unit, Flash                         |   |
| XVUC46    | Blue LED unit, Flash                           |   |
| XVUC47    | White LED unit, Flash                          |   |
| XVUC48    | Yellow LED unit, Flash                         |   |
| A16       | XVUZ100T                                       | Fixing Unit - Metal bracket with pole (100 mm)        |
| XVUZ250T  | Fixing Unit - Metal bracket with pole(250 mm)  |   |
| XVUZ400T  | Fixing Unit - Metal bracket with pole (400 mm) |   |
| A17       | XVUZ12   | Fixing plate for use on vertical support - black      |

## Illuminated Units, Multi-LED and Audible Units Wiring

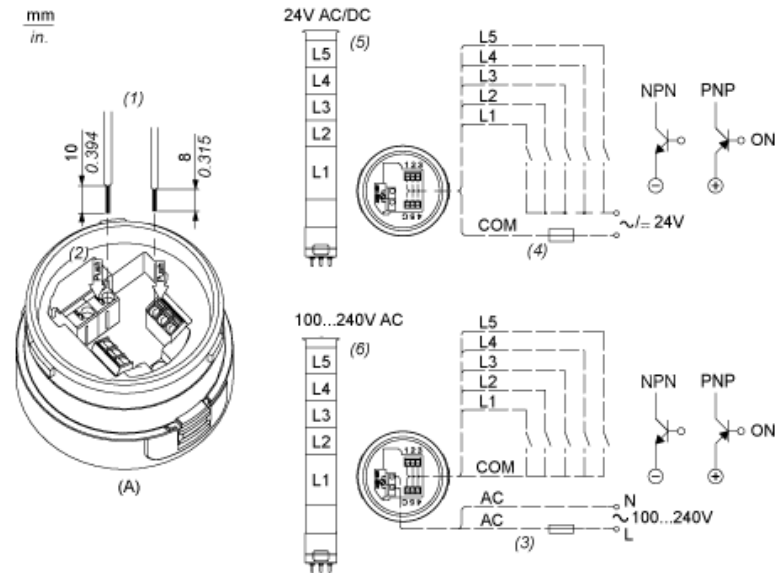

- (A) Fixing Unit
- (1) Dimensions of Wiring size
- (2) Push-in Wire Connectors
- (3) Fuse : 2A ,250V
- (4) Fuse : 0.5A ,125V
- (5) Modular Tower Lights with Audible Units 24V AC/DC
- (6) Modular Tower Lights with Audible Units 100...240V AC
- L1 : Power Channel (Voice)
- L2 to Illuminated LED with Tone Channels
- L5 :