

TL1016 SERIES TACT SWITCH

ANTI-VANDAL SWITCHES
DETECTOR SWITCHES
DIP SWITCHES
KEYLOCK SWITCHES
NAVIGATION SWITCHES
PUSHBUTTON SWITCHES
ROCKER SWITCHES
ROTARY SWITCHES
SLIDE SWITCHES
SNAP ACTION SWITCHES
TACTILE SWITCHES
TOGGLE SWITCHES
CAP OPTIONS

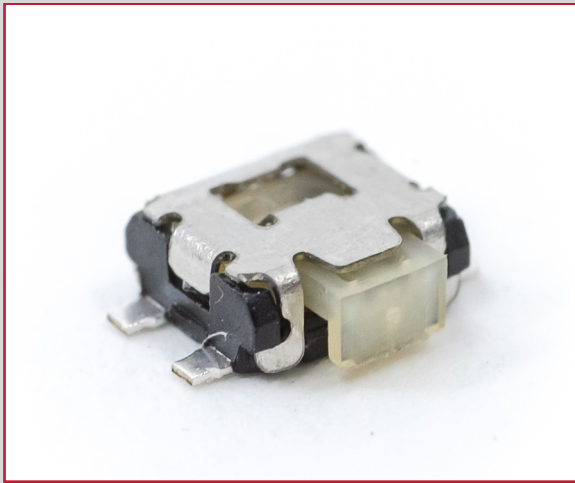

APPLICATIONS / MARKETS

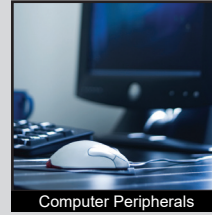

RoHS

SPECIFICATIONS

Electrical Rating: 50mA, 12VDC
Contact Resistance: 500mΩ Max. (Initial)
Insulation Resistance: 100MΩ Min. at 500VDC
Dielectric Strength: 250VAC for 1 Minute
Life Cycles: 100,000 cycles
Operating Temperature: -40°C to 85°C
Storage Temperature: -40°C to 85°C
Travel: 0.20mm +0.2/-0.1mm
Operating Force: 160gf + 70/-40gf
 220gf + 80/-70gf
Function: SPST, Off-(On)
Bounce: 10msec Max.
Contact Material: Silver
Packaging: Tape and Reel, 3,500 pcs/reel

FEATURES & BENEFITS

- Up to 100,000 cycle life expectancy
- Tape and Reel packaging
- Surface mount design
- Actuation force options

PART NUMBER CONFIGURATOR

Series	Circuit	Bosses	Ground Terminal	Actuation Force	Contact Plating	Termination
<input type="text" value="TL"/>	<input type="text" value="1016"/>	<input type="text" value="A"/>	<input type="text" value="A"/>	<input type="text" value="F160"/>	<input type="text" value="Q"/>	<input type="text" value="G"/>
		A - Without Bosses B - With Bosses	A - Without Ground Terminal B - With Ground Terminal	F160 - 160 gf - Black F220 - 220 gf - White	Q - Silver	G - Gull-wing

Specifications subject to change without notice 5.4.2022



E-SWITCH®

www.e-switch.com

800.867.2717

1

TL1016 SERIES TACT SWITCH

BODY DIMENSIONS WITH BOSSES AND WITHOUT GROUND TERMINAL

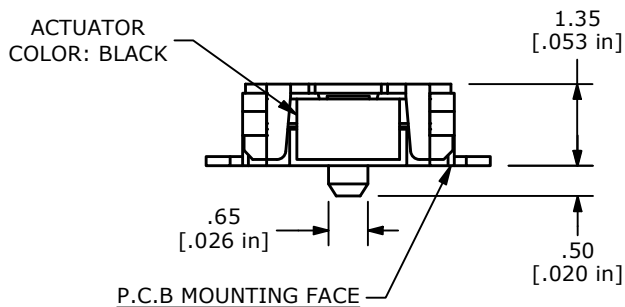
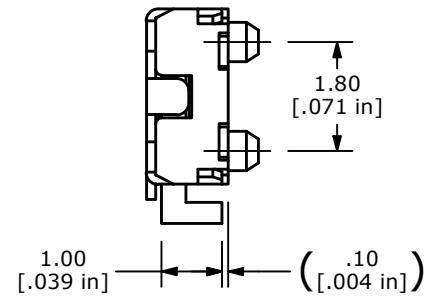
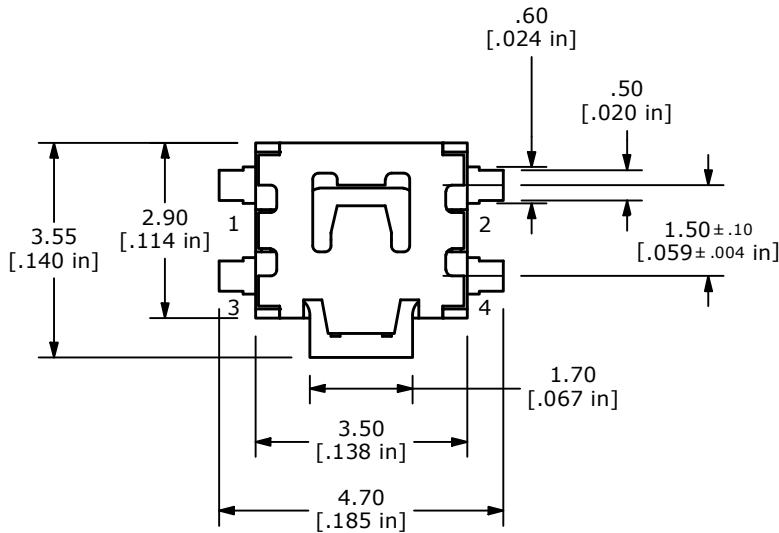
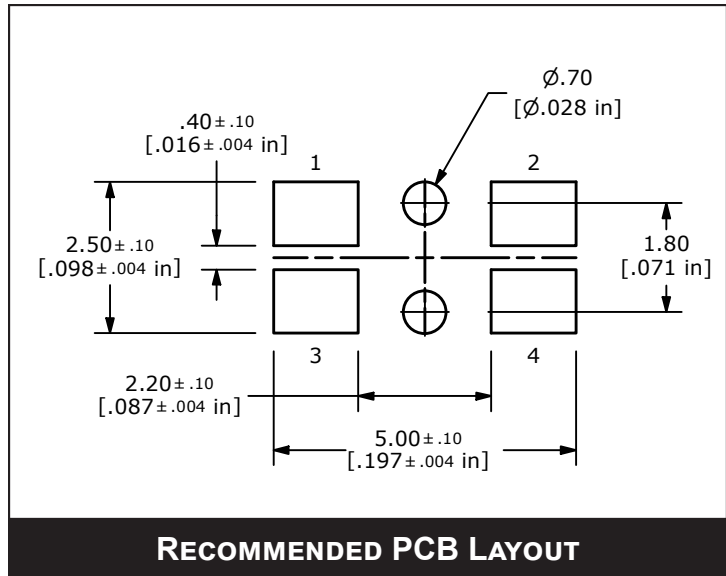
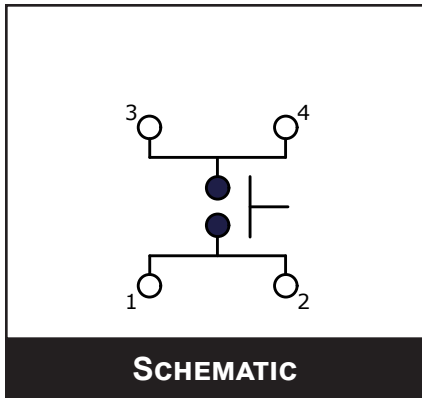

TL1016 SERIES TACT SWITCH

BODY DIMENSIONS WITH GROUND TERMINAL AND WITHOUT BOSSES

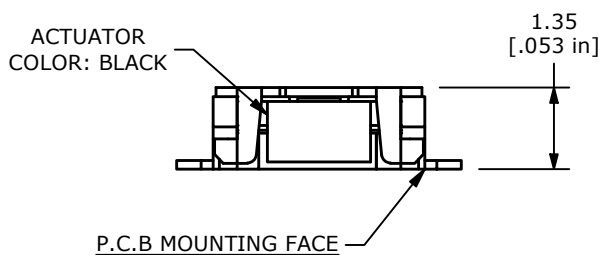
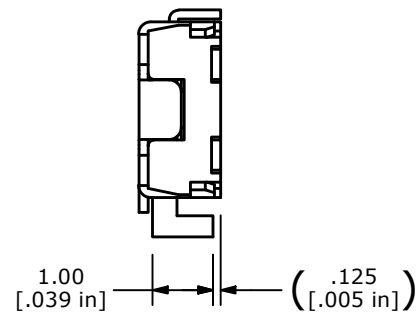
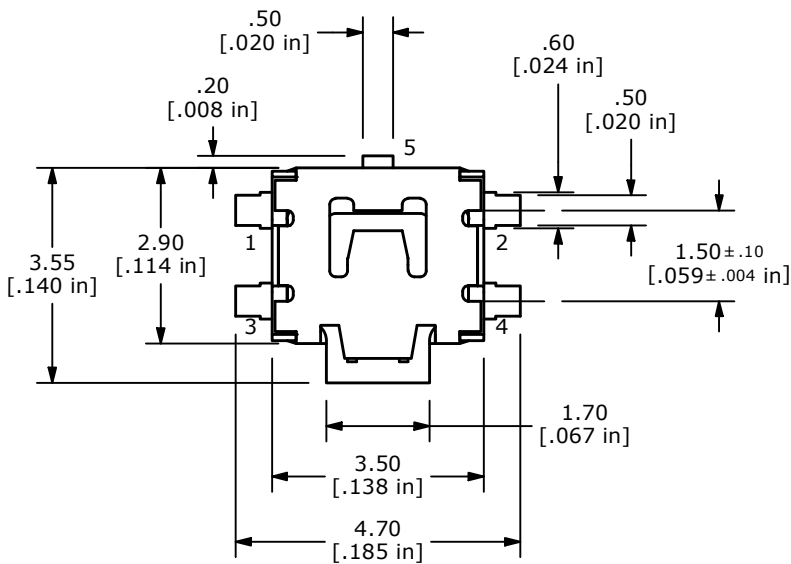
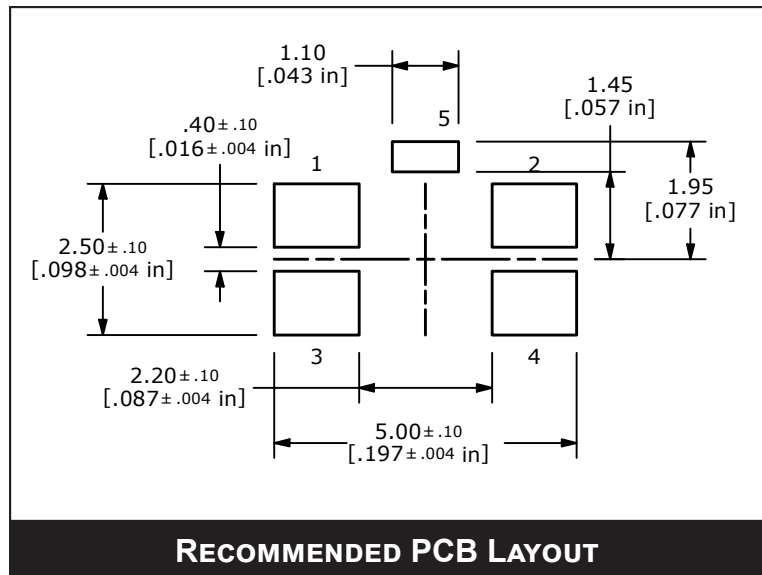
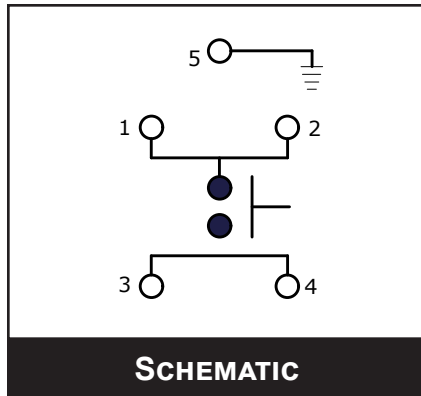

TL1016 SERIES TACT SWITCH

BODY DIMENSIONS WITH BOSSES AND GROUND TERMINAL

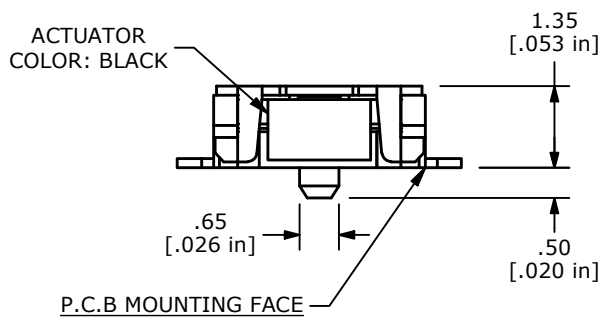
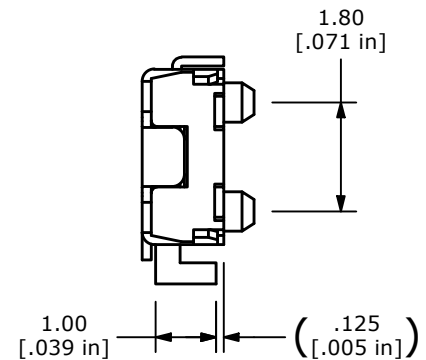
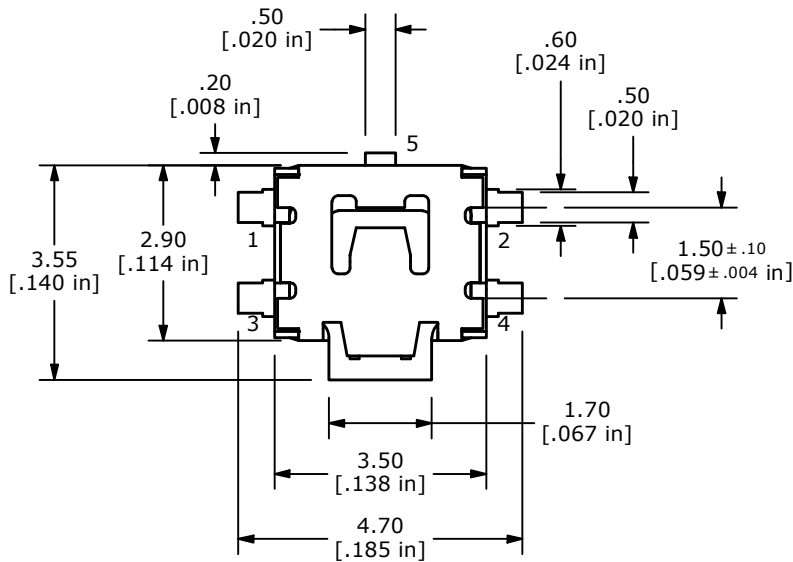
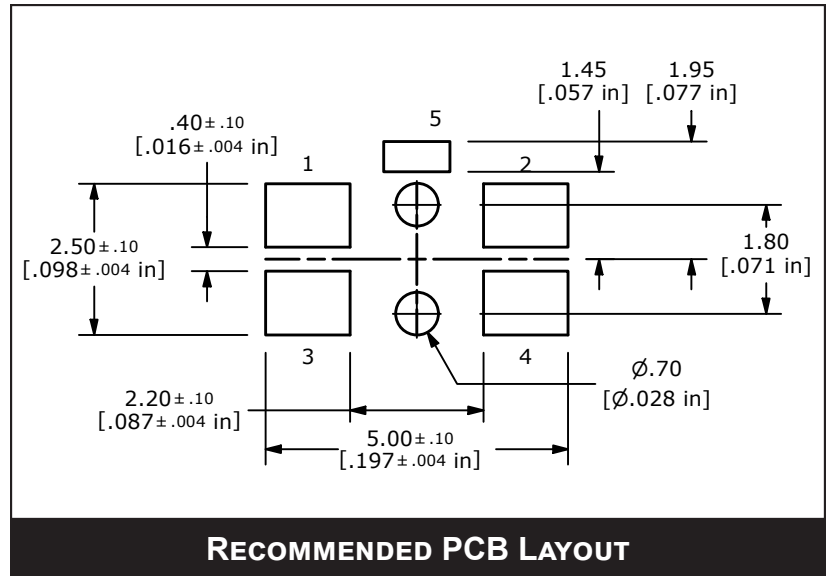
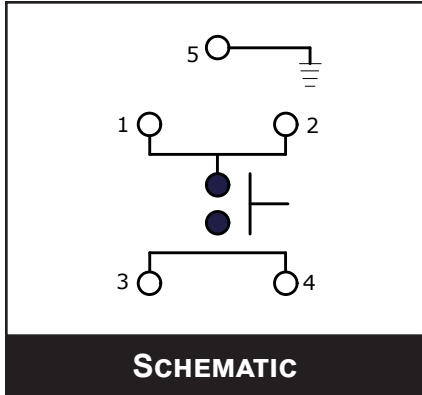

TL1016 SERIES TACT SWITCH

BODY DIMENSIONS TAPE AND REEL

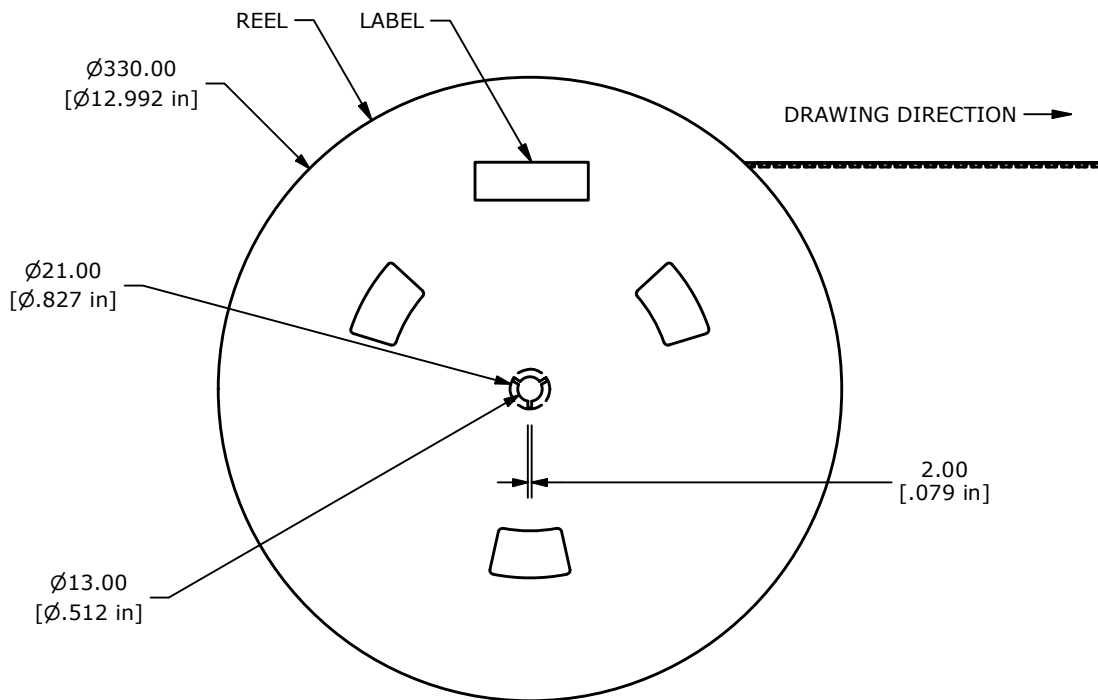
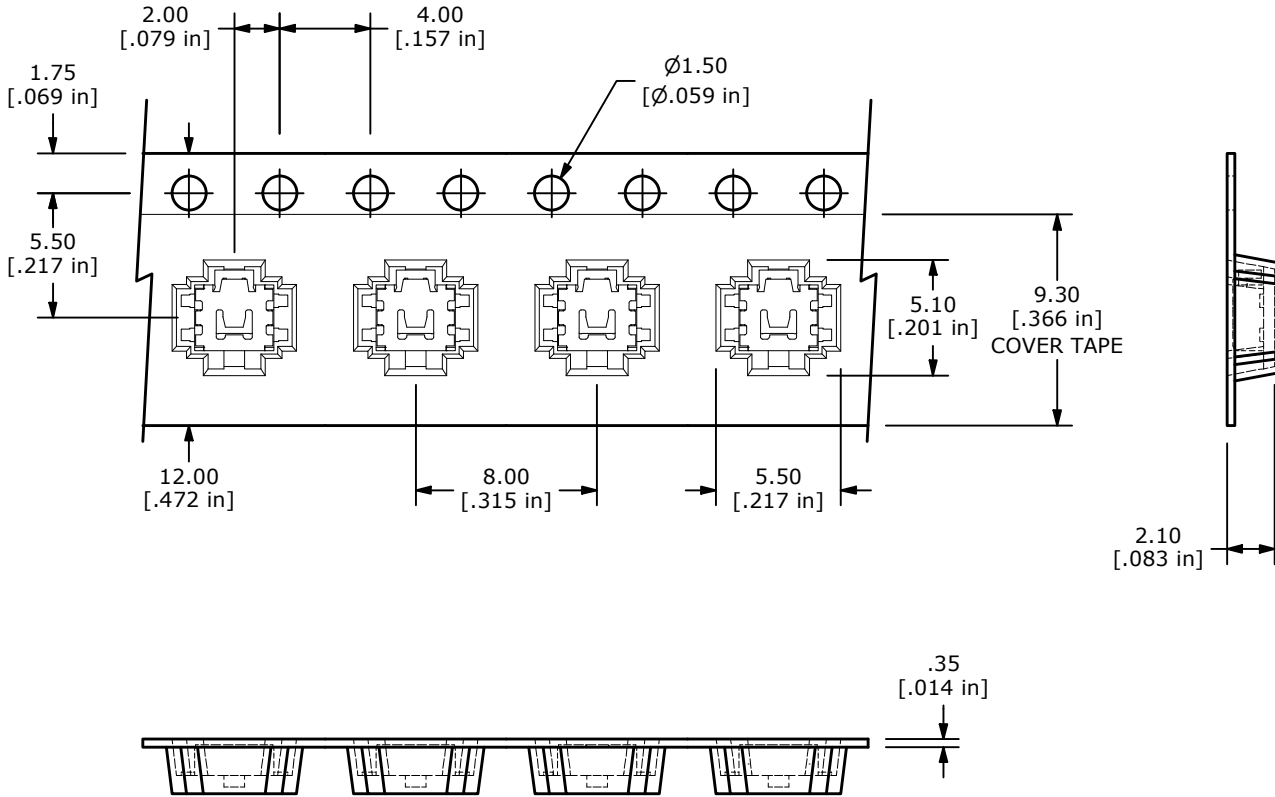

TL1016 SERIES TACT SWITCH

RECOMMENDED SOLDER PROCESS

Most contamination problems can be prevented by exercising care during the cleaning and soldering process. Care should be taken not to immerse or spray unsealed switches during flux removal. Contact E-Switch for specific soldering recommendations and specifications not shown. Generalized soldering procedures are outlined below.

“TYPICAL” SMT REFLOW (Pb and Pb-Free)

Profile Feature	Sn-Pb Eutectic Assembly	Pb-Free Assembly
Average Ramp-Up Rate ($T_{s_{max}}$ to T_p)	3 °C/second max.	3 °C/second max.
Preheat		
-Temperature Min ($T_{s_{min}}$)	100 °C	150 °C
-Temperature Max ($T_{s_{max}}$)	150 °C	200 °C
-Time ($t_{s_{min}}$ to $t_{s_{max}}$)	60-120 seconds	60-180 seconds
Time Maintained above:		
-Temperature (T_L)	183 °C	217 °C
-Time (t_L)	60-150 seconds	60-150 seconds
Time within 5 °C of actual Peak Temperature (t_p)	10-30 seconds	20-40 seconds
Ramp-Down Rate	6 °C/second max.	6 °C/second max.
Time 25 °C to Peak Temperature	6 minutes max.	8 minutes max.

Note 1: All temperatures refer to topside of the package, measured on the package surface.

