

May.1.2023 Copyright 2023 HIROSE ELECTRIC CO., LTD. All Rights Reserved.
In case of consideration for using Automotive equipment / device which demand high reliability, kindly contact our sales window correspondents.

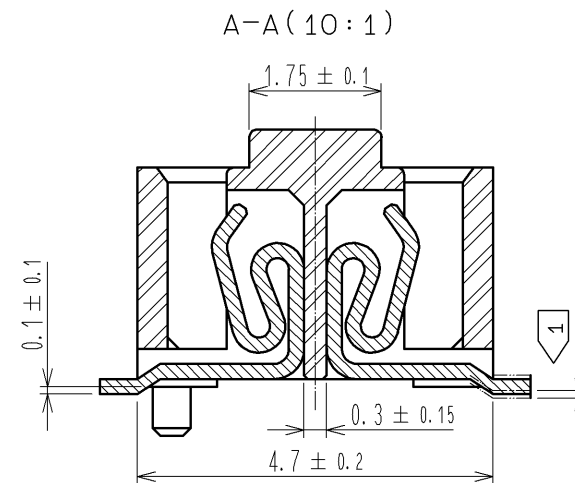
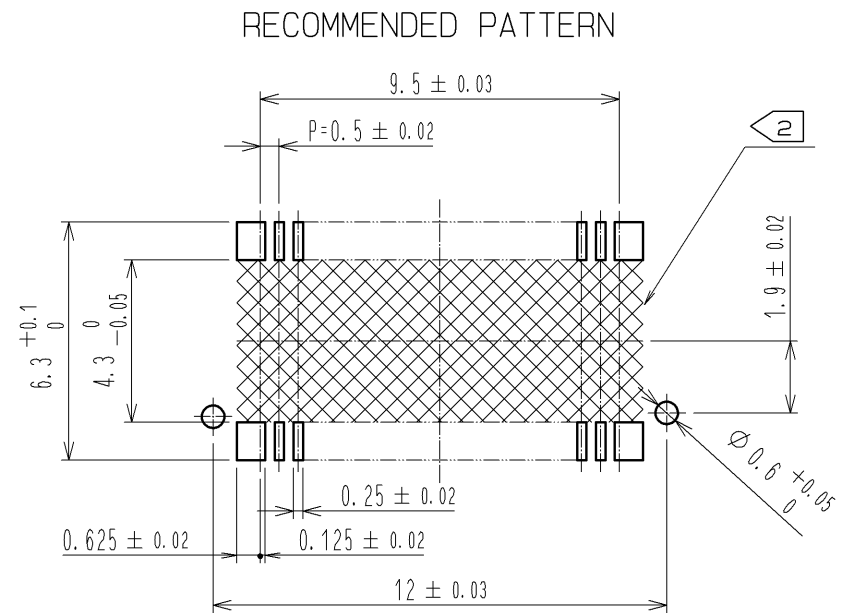
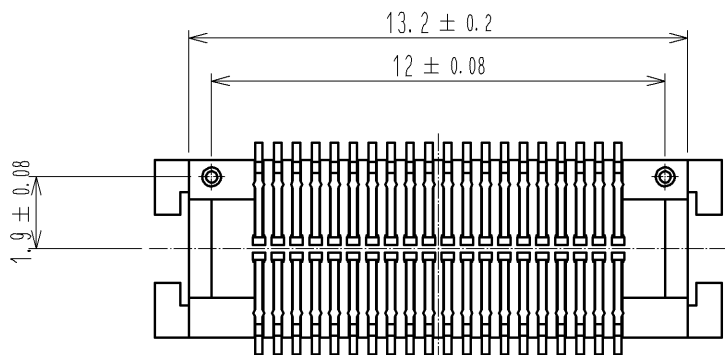
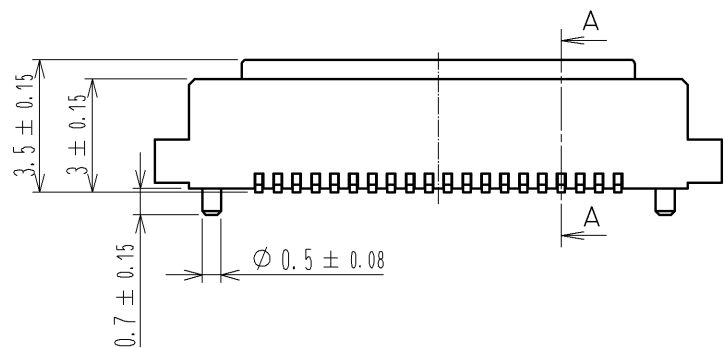
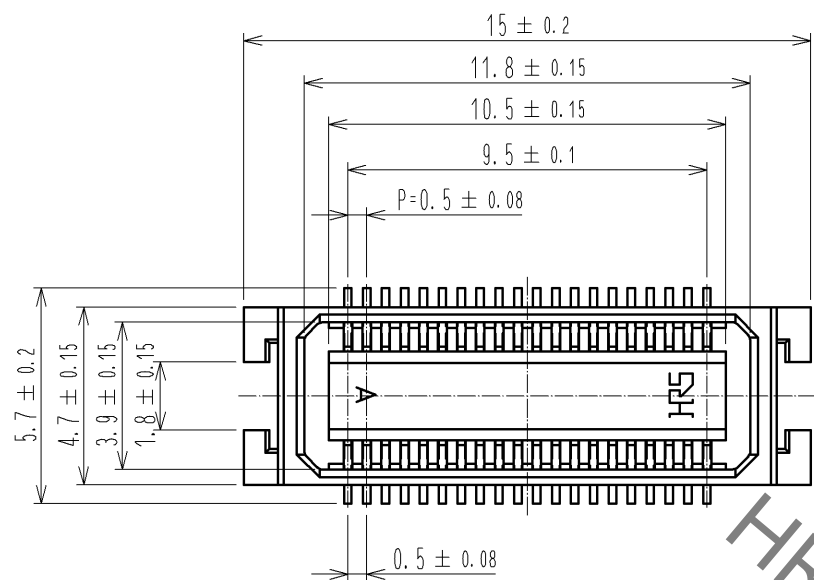

HRS DRAWING FOR REFERENCE

- NOTES 1: LEAD CO-PLANARITY INCLUDE REINFORCED METAL FITTINGS SHALL BE 0.1mm MAX.
2: WHEN A PART MARKED WITH HAS A PATTERN BUT NO RESIST ON IT. TAKE CARE TO PREVENT THE CONNECTOR FROM TOUCHING IT.

MATED HIGHT (h)		(mm)
HEADER NO.	RECEPTACLE NO.	
DF17#(2.0)-40DP-0.5V(57)	DF17A(3.0)-40DS-0.5V(57)	5
DF17#(4.0)-40DP-0.5V(57)		7

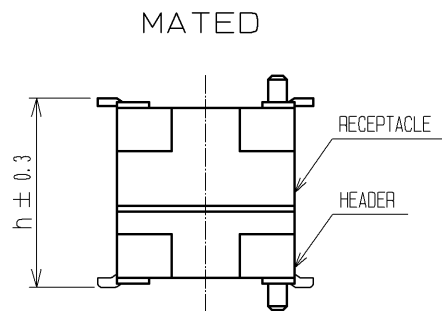

NO.	MATERIAL	FINISH	REMARKS	NO.	MATERIAL	FINISH	REMARKS
2	POLYAMIDE (PA6T)	WHITE BEIGE	UL94V-0	5	PS		BLACK (PLASTIC REEL)
1	PHOSPHER BRONZE	CONTACT AREA:GOLD PLATED 0.1µm min LEAD AREA:GOLD PLATED 0.02µm min UNDER PLATING : NICKEL 1µm min		4	POLYESTER		CLEAR (COVER TAPE)
				3	A-PET		CLEAR (EMBOSSSED CARRIER TAPE)

UNITS	SCALE	COUNT	DESCRIPTION OF REVISIONS	DESIGNED	CHECKED	DATE
mm	5 : 1	△				

HRS HIROSE ELECTRIC CO., LTD.	APPROVED : KH. IKEDA	08.11.20	DRAWING NO.	EDC3-161648-02	
	CHECKED : TS. MIYAZAKI	08.11.20	PART NO.	DF17A(3.0)-40DS-0.5V(57)	
	DESIGNED : TY. YAMASAKI	08.11.19	CODE NO.	CL683-0014-1-57	
	DRAWN : TY. YAMASAKI	08.11.19			

May.1.2023 Copyright 2023 HIROSE ELECTRIC CO., LTD. All Rights Reserved.
 In case of consideration for using Automotive equipment / device which demand high reliability, kindly contact our sales window correspondents.

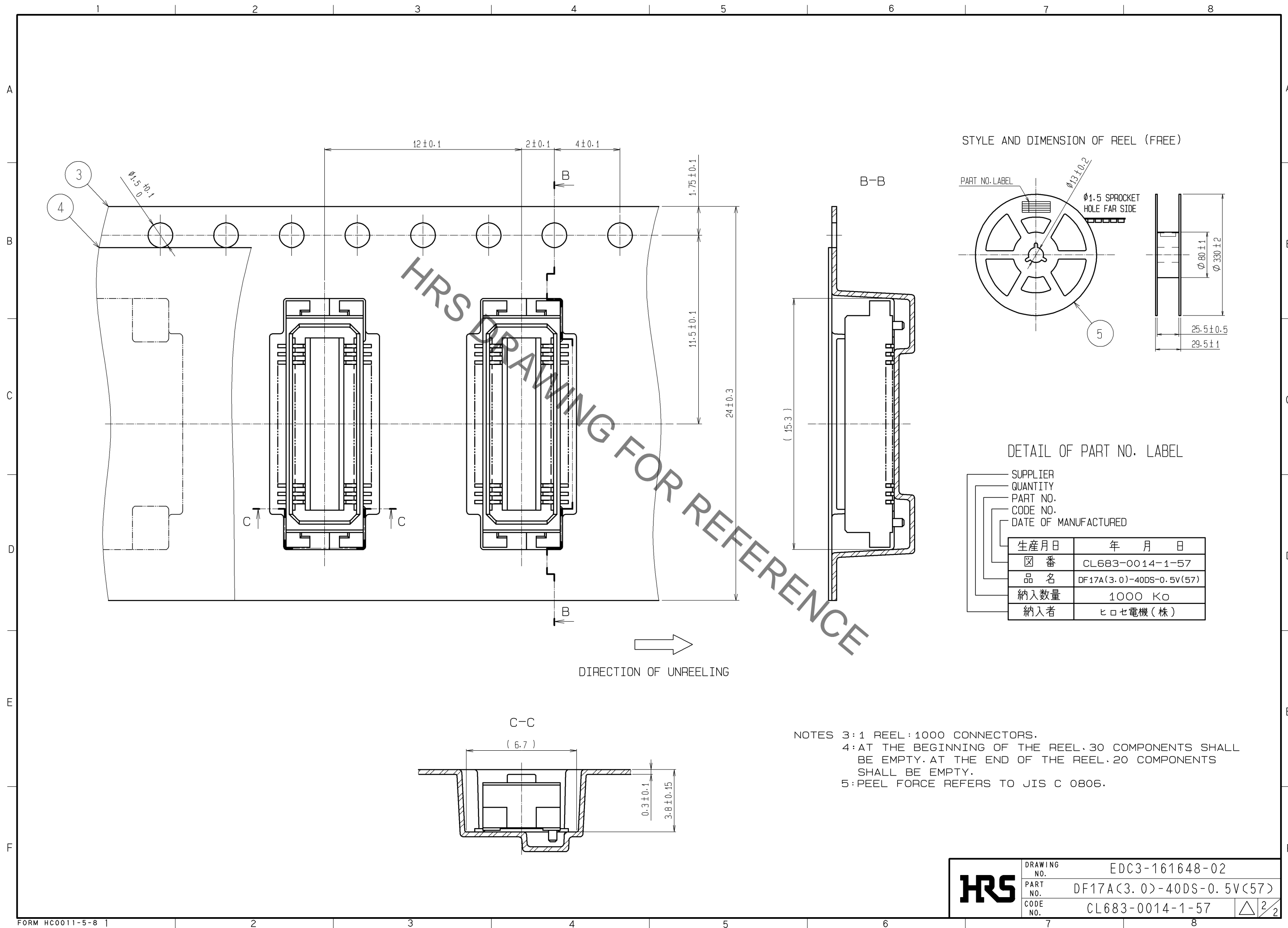

STYLE AND DIMENSION OF REEL (FREE)

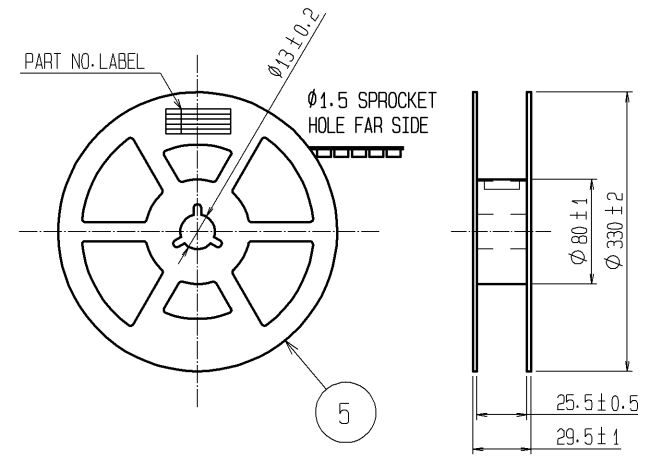

DETAIL OF PART NO. LABEL

SUPPLIER	生産月日	年 月 日
QUANTITY	☑ 番	CL683-0014-1-57
PART NO.	品 名	DF17A(3.0)-40DS-0.5V(57)
CODE NO.	納入数量	1000 KO
DATE OF MANUFACTURED	納入者	ヒロセ電機(株)

➔
DIRECTION OF UNREELING

NOTES 3:1 REEL:1000 CONNECTORS.
 4: AT THE BEGINNING OF THE REEL, 30 COMPONENTS SHALL BE EMPTY. AT THE END OF THE REEL, 20 COMPONENTS SHALL BE EMPTY.
 5: PEEL FORCE REFERS TO JIS C 0806.

HRS	DRAWING NO.	EDC3-161648-02
	PART NO.	DF17A(3.0)-40DS-0.5V(57)
	CODE NO.	CL683-0014-1-57
		\triangle 2/2