



# MAX9509/MAX9510 Evaluation Kits

## General Description

The MAX9509/MAX9510 evaluation kits (EV kits) are fully assembled and tested surface-mount PCBs that evaluate the MAX9509/MAX9510 ICs. The MAX9509/MAX9510 EV kits amplify standard-definition video signals and set the video output black level near ground, while consuming minimal power. The EV kits operate from a 1.7V to 2.625V single power supply.

The MAX9509 EV kit has an additional internal reconstruction filter that typically has  $\pm 1$ dB passband flatness of 8.1MHz, 3dB attenuation at 10MHz, and a 46dB attenuation at 27MHz. Both MAX9509/MAX9510 EV kits provide an internal fixed gain of 8V/V and accept an input full-scale video signal of 0.25V<sub>p-p</sub> (nominal), providing an output full-scale video signal of 2 V<sub>p-p</sub> (nominal).

## Component List

DESIGNATION	QTY	DESCRIPTION
C1, C2	2	1 $\mu$ F $\pm 10\%$ , 10V X7R ceramic capacitors (0603) Murata GRM188R61A105K TDK C1608X7R1A105K
C3	1	0.1 $\mu$ F $\pm 10\%$ , 16V X7R ceramic capacitor (0603) Murata GRM188R71C104K TDK C1608X7R1C104K
C4	1	10 $\mu$ F $\pm 20\%$ , 6.3V X5R ceramic capacitor (0805) Taiyo Yuden JMK212BJ106MG TDK C2012X5R0J106M
C5	0	Not installed, ceramic capacitor (0603)
JU1	1	3-pin header
R1, R2	2	75 $\Omega$ $\pm 1\%$ resistors (0603)
R3	1	0 $\Omega$ $\pm 5\%$ resistor (0603)
U1	1	See the <i>EV Kit-Specific Component List</i>
IN, OUT	2	BNC 75 $\Omega$ PCB vertical mount connectors
—	1	Shunts

## Features

- ◆ Single 1.7V to 2.625V Power-Supply Operation
- ◆ DC-Coupled Input with Option for AC-Coupling
- ◆ DC-Coupled Output
- ◆ Video Output Black Level Set Near Ground
- ◆ Reconstruction Filter with  $\pm 1$ dB Passband to 8.1MHz and 46dB Attenuation at 27MHz (MAX9509)
- ◆ Internal Preset Gain of 8V/V
- ◆ 10nA Shutdown Current
- ◆ 8-Pin TDFN Package (MAX9509), 8-Pin  $\mu$ MAX<sup>®</sup> Package (MAX9510)
- ◆ Surface-Mount Components
- ◆ Fully Assembled and Tested
- ◆ Lead-Free and RoHS Compliant

## Ordering Information

PART	TEMP RANGE	IC PACKAGE
MAX9509EVKIT+	0°C to +70°C*	8 TDFN-EP** (2mm x 2mm x 0.8mm)
MAX9510EVKIT+	0°C to +70°C*	8 $\mu$ MAX

+ Denotes a lead-free and RoHS-compliant EV kit.

\* This limited temperature range is for the EV kit PCB only. The MAX9509/MAX9510 IC temperature range is -40°C to +125°C.

\*\*EP = Expose paddle.

## Component Suppliers

SUPPLIER	PHONE	WEBSITE
Murata	770-436-1300	www.murata.com
Taiyo Yuden	800-348-2496	www.t-yuden.com
TDK Corp.	847-803-6100	www.component.tdk.com

**Note:** Indicate that you are using the MAX9509/MAX9510 when contacting these component suppliers.

## EV Kit-Specific Component List

EV KIT PART NUMBER	QTY	REFERENCE DESIGNATOR	DESCRIPTION	PCB NAME
MAX9509EVKIT+	1	U1	MAX9509ATA+ (8-pin, 2mm x 2mm x 0.8mm, TDFN) Top Mark AAZ	MAX9509 Evaluation Kit+
MAX9510EVKIT+	1		MAX9510AUA+ (8-pin $\mu$ MAX)	MAX9510 Evaluation Kit+

$\mu$ MAX is a registered trademark of Maxim Integrated Products, Inc.



**For pricing, delivery, and ordering information, please contact Maxim/Dallas Direct! at 1-888-629-4642, or visit Maxim's website at www.maxim-ic.com.**

# MAX9509/MAX9510 Evaluation Kits

## Quick Start

### Recommended Equipment

- 1.7V to 2.625V, 500mA DC power supply (VDD)
- Video signal generator
- Video measurement equipment (e.g., Tektronix VM-700T)

### Procedure

The MAX9509/MAX9510 EV kits are fully assembled and tested. Follow the steps below to verify board operation. **Caution:** Do not turn on the power supply until all connections are completed.

- 1) Verify that a shunt is installed across pins 2-3 of jumper JU1 (EV kit enabled).
- 2) Connect the power supply ground to the GND pad on the EV kit.
- 3) Connect the 1.7V to 2.625V supply to the VDD pad on the EV kit.
- 4) Connect the output of the video signal generator to the IN BNC connector on the EV kit. **The video signal must be biased such that the sync tip is at ground.**
- 5) Connect the OUT BNC connector on the EV kit to the input of the video measurement equipment.
- 6) Set the video signal generator for the desired video input signal.
- 7) Turn on the power supply and enable the video signal generator.
- 8) Analyze the video output signal with the VM-700T video measurement equipment.

### Detailed Description

The MAX9509/MAX9510 EV kits are fully assembled and tested surface-mount PCBs that evaluate the MAX9509/MAX9510 ICs. The MAX9509/MAX9510 amplify and set the video output black level near ground for standard-definition video signals, while consuming minimal power. The EV kits operate from a 1.7V to 2.625V single power supply.

The MAX9509 EV kit has an additional internal reconstruction filter that smoothes the steps and reduces the spikes on the video signal from the video digital-to-analog converter (DAC). The reconstruction filter typically has  $\pm 1$ dB passband flatness of 8.1MHz, 3dB attenuation at 10MHz, and 46dB attenuation at 27MHz.

Both MAX9509/MAX9510 EV kits provide an internal fixed gain of 8V/V and accept an input full-scale video signal of 0.25V<sub>P-P</sub> (nominal), providing an output full-scale video signal of 2V<sub>P-P</sub> (nominal).

Video input and output signals from the EV kits are DC-coupled, eliminating large DC-blocking capacitors. The input of each EV kit has a 75Ω termination to ground and the output has a 75Ω back-termination resistor.

The input of the MAX9509/MAX9510 EV kits can be directly connected to the output of a video DAC. The MAX9509/MAX9510 also feature a transparent input sync-tip clamp, allowing AC-coupling of input signals with different DC biases.

### Jumper Selection

#### Shutdown Mode ( $\overline{\text{SHDN}}$ )

Jumper JU1 controls the shutdown mode ( $\overline{\text{SHDN}}$ ) of the MAX9509/MAX9510 EV kits. The shutdown mode turns off the sync-tip clamp, filter (MAX9509), amplifier, charge pump, and linear regulator, and reduces the IC's quiescent supply current to 10nA (typ). See *Table 1* for JU1 jumper selection.

**Table 1. JU1 Jumper Selection**

SHUNT POSITION	$\overline{\text{SHDN}}$ PIN	EV KIT FUNCTION
1-2	Low	Disabled
2-3*	High	Enabled

\*Default position.

### AC-Coupled Input

By default, the MAX9509/MAX9510 EV kits are set for a DC-coupled input. However, these kits are configured for an AC-coupled input as well. To change the setting to AC-coupled, remove R3 and install a 0.1μF ceramic capacitor across the C5 pads.

# MAX9509/MAX9510 Evaluation Kits

Evaluate: MAX9509/MAX9510

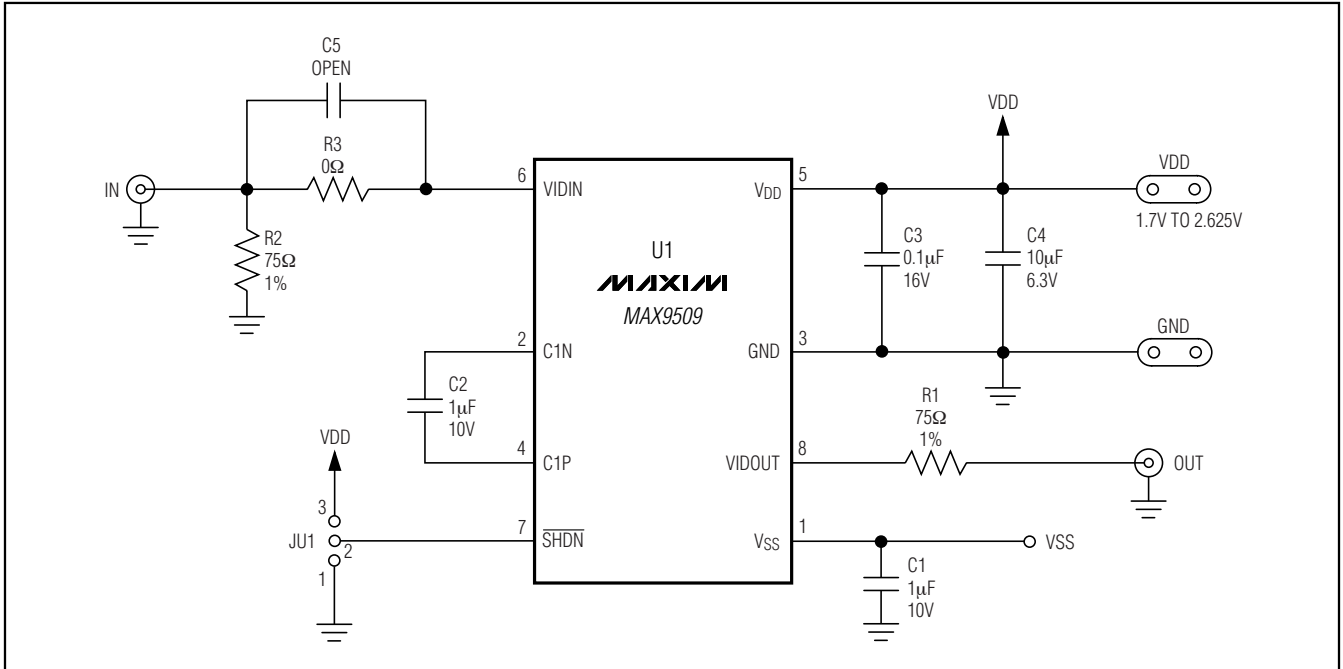

Figure 1. MAX9509 EV Kit Schematic

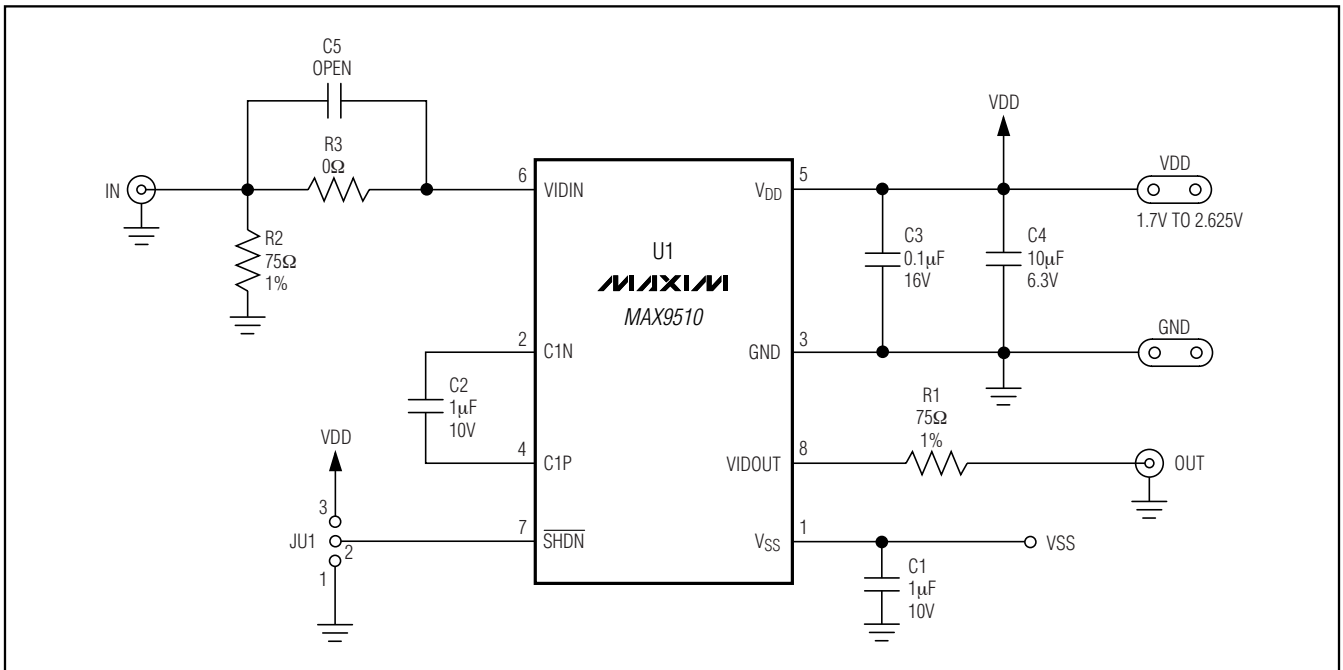

Figure 2. MAX9510 EV Kit Schematic

# MAX9509/MAX9510 Evaluation Kits

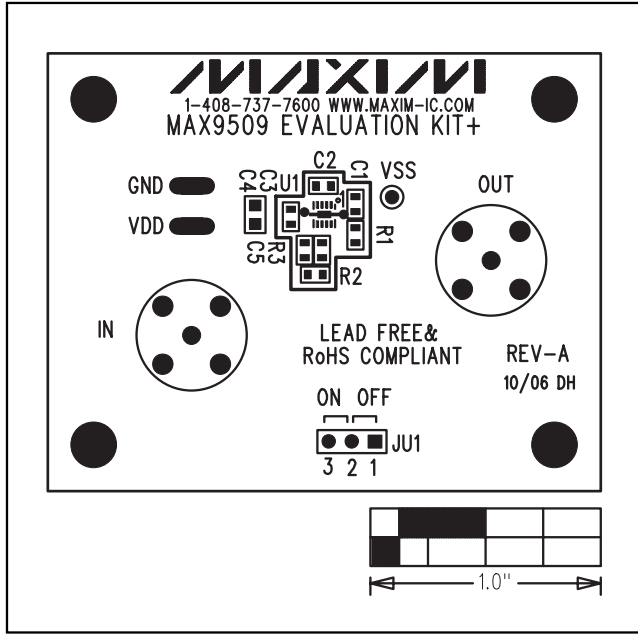

Figure 3. MAX9509 EV Kit Component Placement Guide—Component Side

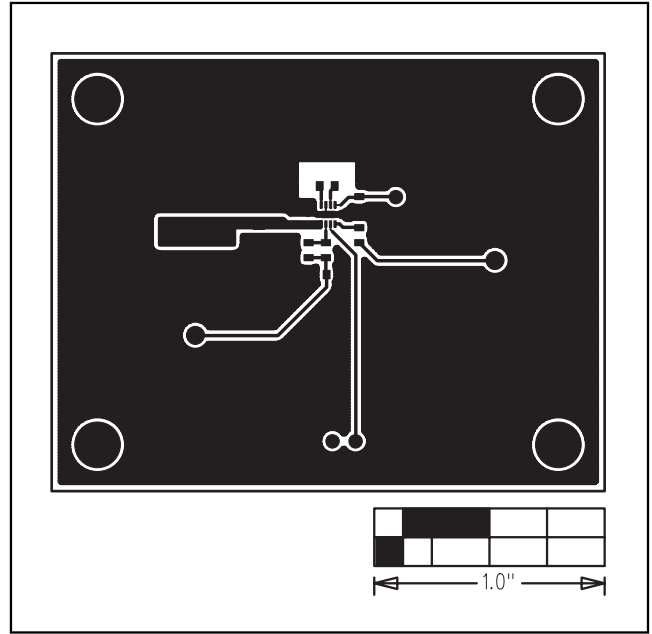

Figure 4. MAX9509 EV Kit PCB Layout—Component Side

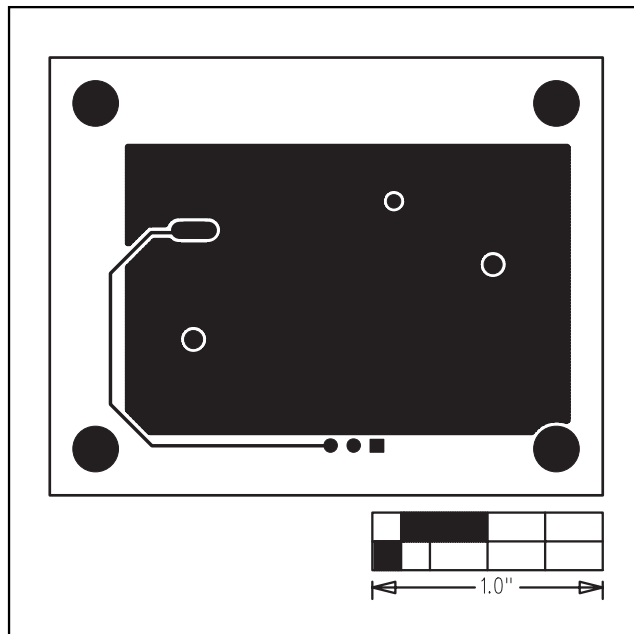

Figure 5. MAX9509 EV Kit PCB Layout—Solder Side

# MAX9509/MAX9510 Evaluation Kits

Evaluate: MAX9509/MAX9510

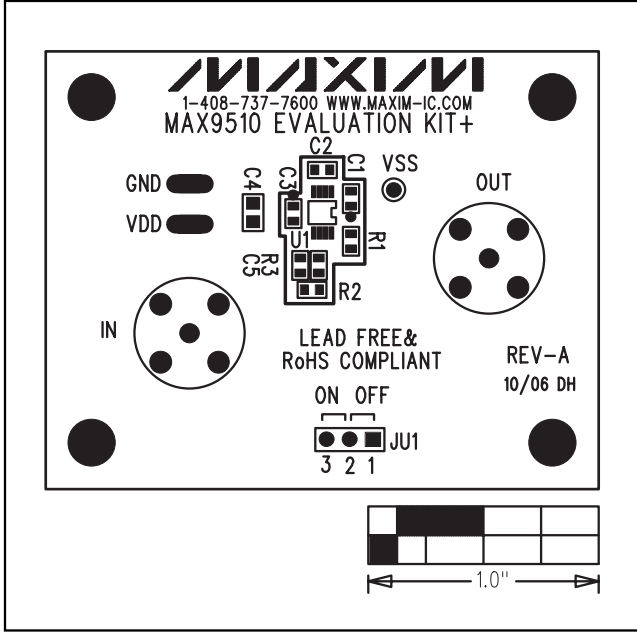

Figure 6. MAX9510 EV Kit Component Placement Guide—Component Side

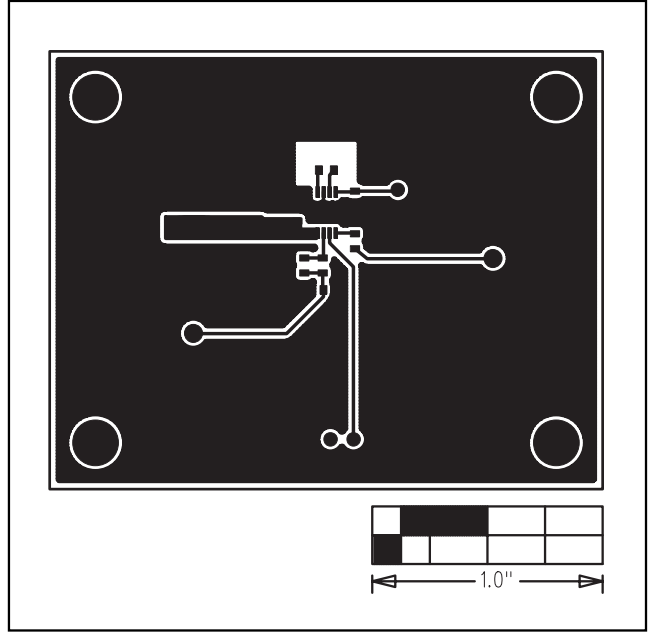

Figure 7. MAX9510 EV Kit PCB Layout—Component Side

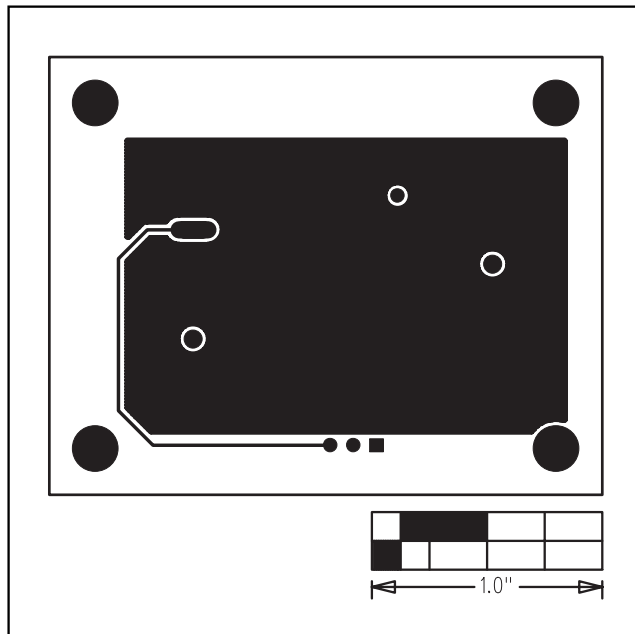

Figure 8. MAX9510 EV Kit PCB Layout—Solder Side

Maxim cannot assume responsibility for use of any circuitry other than circuitry entirely embodied in a Maxim product. No circuit patent licenses are implied. Maxim reserves the right to change the circuitry and specifications without notice at any time.

Maxim Integrated Products, 120 San Gabriel Drive, Sunnyvale, CA 94086 408-737-7600 \_\_\_\_\_ 5