



### General Description

Renesas SLG7NT4317 is a low power and small form device. The SoC is housed in a 2mm x 3mm TQFN package which is optimal for using with small devices.

### Features

- Low Power Consumption
- 3.3V Supply
- Pb-Free / RoHS Compliant
- Halogen-Free
- STQFN-20 Package

### Output Summary

- 6 Outputs – NMOS Open Drain 1X

### Pin Configuration

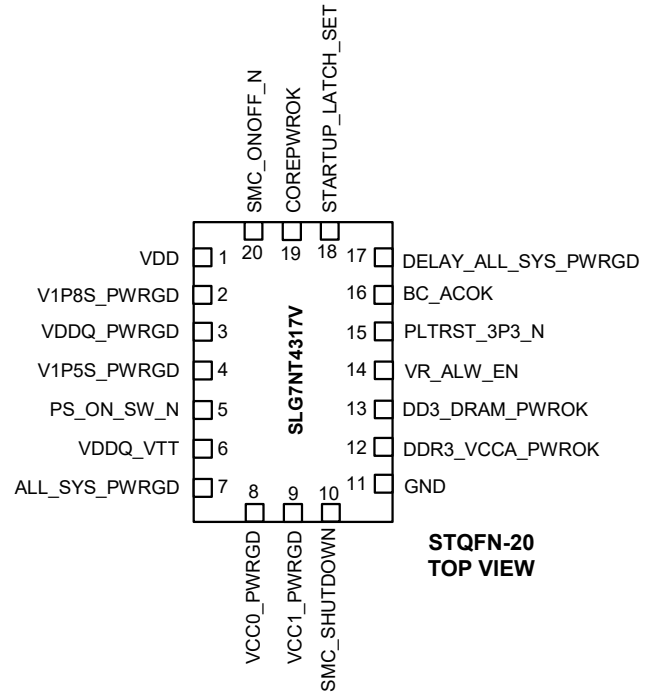

### Block Diagram

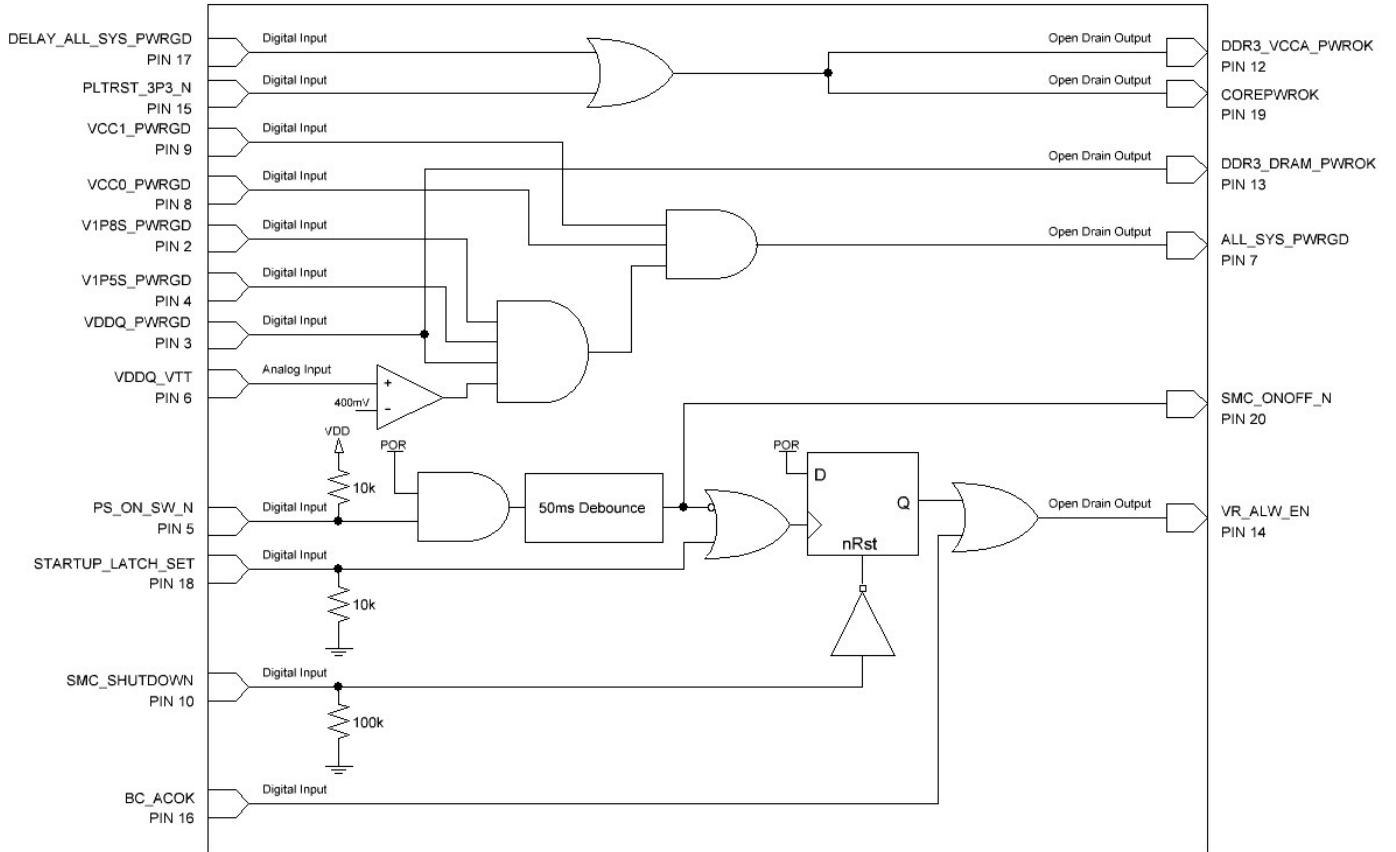

### Pin Configuration

Pin #	Pin Name	Type	Pin Description
1	VDD	PWR	Supply Voltage
2	V1P8S_PWRGD	Input	Digital Input
3	VDDQ_PWRGD	Input	Digital Input with Schmitt Trigger
4	V1P5S_PWRGD	Input	Digital Input
5	PS_ON_SW_N	Input	Digital Input with Schmitt Trigger
6	VDDQ_VTT	Input	Analog Input
7	ALL_SYS_PWRGD	Output	NMOS Open Drain 1X
8	VCC0_PWRGD	Input	Digital Input
9	VCC1_PWRGD	Input	Digital Input
10	SMC_SHUTDOWN	Input	Digital Input
11	GND	--	Ground
12	DDR3_VCCA_PWROK	Output	NMOS Open Drain 1X
13	DDR3_DRAM_PWROK	Output	NMOS Open Drain 1X
14	VR_ALW_EN	Output	NMOS Open Drain 1X
15	PLTRST_3P3_N	Input	Digital Input
16	BC_ACOK	Input	Digital Input
17	DELAY_ALL_SYS_PWRGD	Input	Digital Input
18	STARTUP_LATCH_SET	Input	Digital Input
19	COREPWROK	Output	NMOS Open Drain 1X
20	SMC_ONOFF_N	Output	NMOS Open Drain 1X

### Ordering Information

Part Number	Package Type
SLG7NT4317V	V=STQFN-20
SLG7NT4317VTR	STQFN-20 – Tape and Reel (3k units)

### Absolute Maximum Conditions

Parameter	Min.	Max.	Unit
V <sub>HIGH</sub> to GND	-0.3	7	V
Voltage at input pins	-0.3	7	V
Current at input pin	-1.0	1.0	mA
Storage temperature range	-65	150	°C
Junction temperature	--	150	°C

### Electrical Characteristics

(@ 25°C, unless otherwise stated)

Symbol	Parameter	Condition/Note	Min.	Typ.	Max.	Unit
V <sub>DD</sub>	Supply Voltage		3	--	4.5	V
T <sub>A</sub>	Operating Temperature		-40	25	85	°C
I <sub>Q</sub>	Quiescent Current	Static inputs and outputs at VDD=4.5V	--	70	--	μA
I <sub>L</sub>	Input Leakage Current	Leakage Current for Digital Inputs or outputs in High impedance state	-1	--	1	μA
V <sub>IH</sub>	HIGH-Level Input Voltage	Logic Input at VDD=3.3V	1.78	--	--	V
		Logic Input at VDD=5V	2.64	--	--	
		Logic Input with Schmitt trigger at VDD=3.3V	2.13	--	--	
		Logic Input with Schmitt trigger at VDD=5V	3.16	--	--	
V <sub>IL</sub>	LOW-Level Input Voltage	Logic Input at VDD=3.3V	--	--	1.21	V
		Logic Input at VDD=5V	--	--	1.84	
		Logic Input with Schmitt trigger at VDD=3.3V	--	--	0.95	
		Logic Input with Schmitt trigger at VDD=5V	--	--	0.78	
I <sub>IH</sub>	HIGH-Level Input Current	Logic Input Pins; V <sub>IN</sub> = 3.3 V	-1.0	--	1.0	μA
I <sub>IL</sub>	LOW-Level Input Current	Logic Input Pins; V <sub>IN</sub> = 0 V	-1.0	--	1.0	μA
V <sub>OL</sub>	LOW-Level Output Voltage	Open Drain, at VDD=3.3V, I <sub>OL</sub> = 3 mA, 1X Driver	--	0.08	0.147	V
		Open Drain, at VDD=5V, I <sub>OL</sub> = 3 mA, 1X Driver	--	0.102	0.180	
I <sub>OL</sub>	LOW-Level Output Current	Open Drain, at VDD=3.3V, V <sub>OL</sub> = 0.4 V 1X Driver	7.313	12.37	--	mA
		Open Drain, at VDD=5V, V <sub>OL</sub> = 0.4 V, 1X Driver	10.82	17.38	--	
V <sub>ACMP</sub>	Analog Comparator Threshold Voltage	ACMP0 threshold including input offset, V <sub>ref</sub> variation and hysteresis at 25°C temperature	368	--	432	mV
V <sub>HYST</sub>	Analog Comparator Hysteresis	ACMP0, at 25°C	--	25	--	mV

$V_O$	Maximal Voltage Applied to any PIN in High-Impedance State		--	--	VDD	V
$I_O$	Maximal Average or DC Current	Per Each Side (PIN2-PIN10, PIN12-PIN20)	--	--	80	mA
$T_{DLY0}$	Delay0 Time	At 25°C temperature	48	--	52	ms
		At 0-70°C temperature range	44	--	56	
$R_{PU}$	Internal Pull Up Resistance	On PIN5	7	10	13	kΩ
$R_{PD}$	Internal Pull Down Resistance	On PIN18	7	10	13	kΩ
		On PIN10	70	100	130	
$T_{SU}$	Start up Time	After VDD reaches 1.6V level	--	1	--	ms

### Package Top Marking

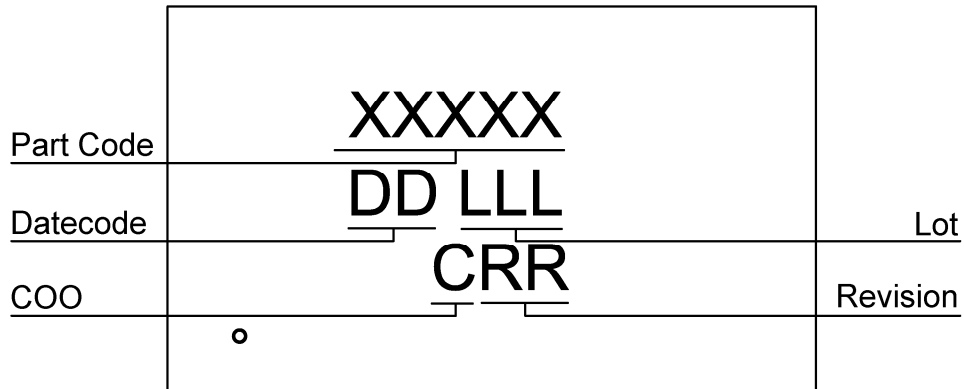

XXXXX – Part ID Field: identifies the specific device configuration  
 DD – Date Code Field: Coded date of manufacture  
 LLL – Lot Code: Designates Lot #  
 C – Assembly Site/COO: Specifies Assembly Site/Country of Origin  
 RR – Revision Code: Device Revision

Datasheet Revision	Programming Code Number	Locked Status	Part Code	Revision	Date
1.01	004	L	4317V	AB	02/25/2022

The IC security bit is locked/set for code security for production unless otherwise specified. Revision number is not changed for bit locking

### Package Drawing and Dimensions

#### 20 Lead STQFN Package JEDEC MO-220, Variation WECE

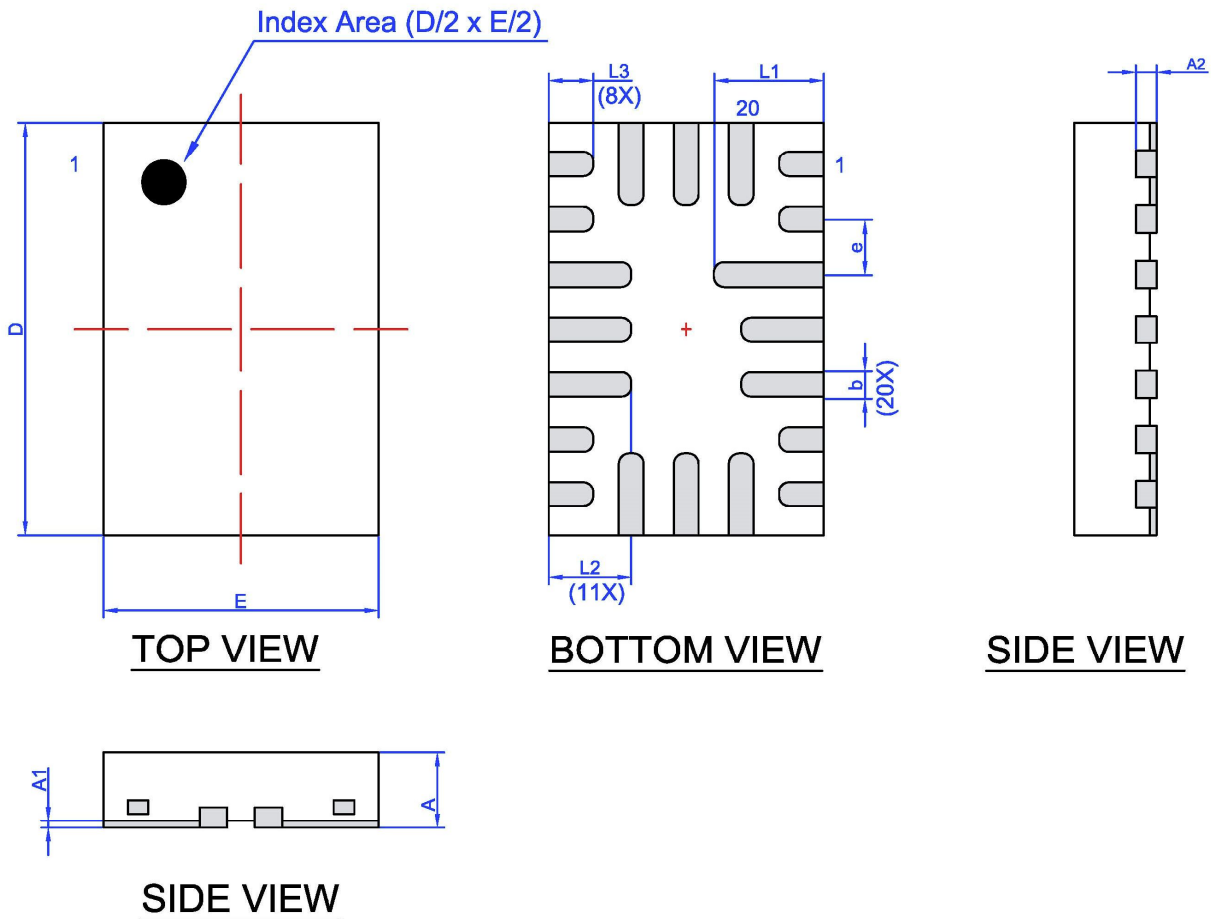

Unit: mm

Symbol	Min	Nom.	Max	Symbol	Min	Nom.	Max
A	0.50	0.55	0.60	D	2.95	3.00	3.05
A1	0.005	-	0.050	E	1.95	2.00	2.05
A2	0.10	0.15	0.20	L1	0.75	0.80	0.85
b	0.13	0.18	0.23	L2	0.55	0.60	0.65
e	0.40 BSC			L3	0.275	0.325	0.375

### Tape and Reel Specification

Package Type	# of Pins	Nominal Package Size (mm)	Max Units		Reel & Hub Size (mm)	Trailer A		Leader B		Pocket (mm)	
			per reel	per box		Pockets	Length (mm)	Pockets	Length (mm)	Width	Pitch
STQFN 20L 2x3mm 0.4P Green	20	2x3x0.55	3000	3000	178/60	100	400	100	400	8	4

### Carrier Tape Drawing and Dimensions

Package Type	Pocket BTM Length (mm)	Pocket BTM Width (mm)	Pocket Depth (mm)	Index Hole Pitch (mm)	Pocket Pitch (mm)	Index Hole Diameter (mm)	Index Hole to Tape Edge (mm)	Index Hole to Pocket Center (mm)	Tape Width (mm)
	A0	B0	K0	P0	P1	D0	E	F	W
STQFN 20L 2x3mm 0.4P Green	2.2	3.15	0.76	4	4	1.5	1.75	3.5	8

Refer to EIA-481 Specifications

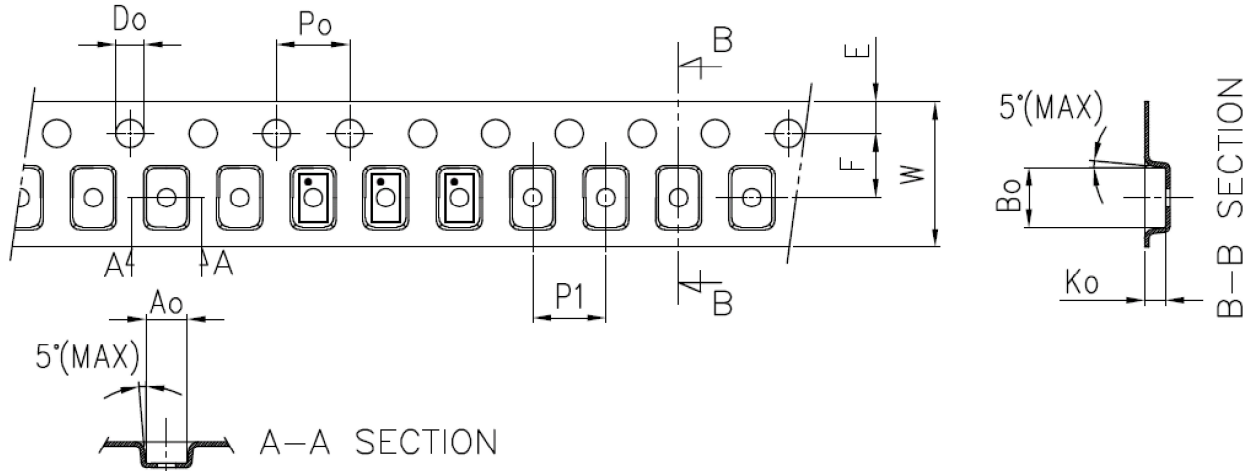

### Recommended Reflow Soldering Profile

Please see IPC/JEDEC J-STD-020: latest revision for reflow profile based on package volume of 3.3 mm<sup>3</sup> (nominal). More information can be found at [www.jedec.org](http://www.jedec.org).



## IMPORTANT NOTICE AND DISCLAIMER

RENESAS ELECTRONICS CORPORATION AND ITS SUBSIDIARIES (“RENESAS”) PROVIDES TECHNICAL SPECIFICATIONS AND RELIABILITY DATA (INCLUDING DATASHEETS), DESIGN RESOURCES (INCLUDING REFERENCE DESIGNS), APPLICATION OR OTHER DESIGN ADVICE, WEB TOOLS, SAFETY INFORMATION, AND OTHER RESOURCES “AS IS” AND WITH ALL FAULTS, AND DISCLAIMS ALL WARRANTIES, EXPRESS OR IMPLIED, INCLUDING, WITHOUT LIMITATION, ANY IMPLIED WARRANTIES OF MERCHANTABILITY, FITNESS FOR A PARTICULAR PURPOSE, OR NON-INFRINGEMENT OF THIRD PARTY INTELLECTUAL PROPERTY RIGHTS.

These resources are intended for developers skilled in the art designing with Renesas products. You are solely responsible for (1) selecting the appropriate products for your application, (2) designing, validating, and testing your application, and (3) ensuring your application meets applicable standards, and any other safety, security, or other requirements. These resources are subject to change without notice. Renesas grants you permission to use these resources only for development of an application that uses Renesas products. Other reproduction or use of these resources is strictly prohibited. No license is granted to any other Renesas intellectual property or to any third party intellectual property. Renesas disclaims responsibility for, and you will fully indemnify Renesas and its representatives against, any claims, damages, costs, losses, or liabilities arising out of your use of these resources. Renesas' products are provided only subject to Renesas' Terms and Conditions of Sale or other applicable terms agreed to in writing. No use of any Renesas resources expands or otherwise alters any applicable warranties or warranty disclaimers for these products.

(Rev.1.0 Mar 2020)

### Corporate Headquarters

TOYOSU FORESIA, 3-2-24 Toyosu,  
Koto-ku, Tokyo 135-0061, Japan  
[www.renesas.com](http://www.renesas.com)

### Contact Information

For further information on a product, technology, the most up-to-date version of a document, or your nearest sales office, please visit:  
[www.renesas.com/contact/](http://www.renesas.com/contact/)

### Trademarks

Renesas and the Renesas logo are trademarks of Renesas Electronics Corporation. All trademarks and registered trademarks are the property of their respective owners.