

Order No.	Shell Size / for No. of Contacts	A ±0.3	B ±0.1	C ±0.3	D ±0.3	E ±0.3	∅F min - max	G ±0.3	H ±0.3	J ±0.3	K ±0.3	L ±0.3	M ±0.3	N ±0.5	P ±0.3	Q
FKC1GA	1 / 9	10	25	31.8	39.2	16.7	4 - 11	20	41.6	13.2	17	19	20	25.3	14	3.9
FKC2GA	2 / 15	16	33.3	41.2	45	16.2	4 - 11	28.4	47.8	11.6	24.8	26.9	27.9	26.3	18	3.9
FKC3GA	3 / 25	28	47	54.9	52	16.2	4 - 12	42.1	54.8	11.6	38.2	40.5	41.4	32.8	18	3.9
FKC4GA	4 / 37	44.4	63.5	71.4	55	18.9	6 - 13	58.6	57.8	12.1	55	57.2	58.1	38.4	21	3.9
FKC5GA	5 / 50	42	61.1	69	55	19.5	6 - 14	56.2	57.8	15	52.6	54.7	55.7	40.2	21	4.1

∅F = Cable diameter

view of the hoods without lid

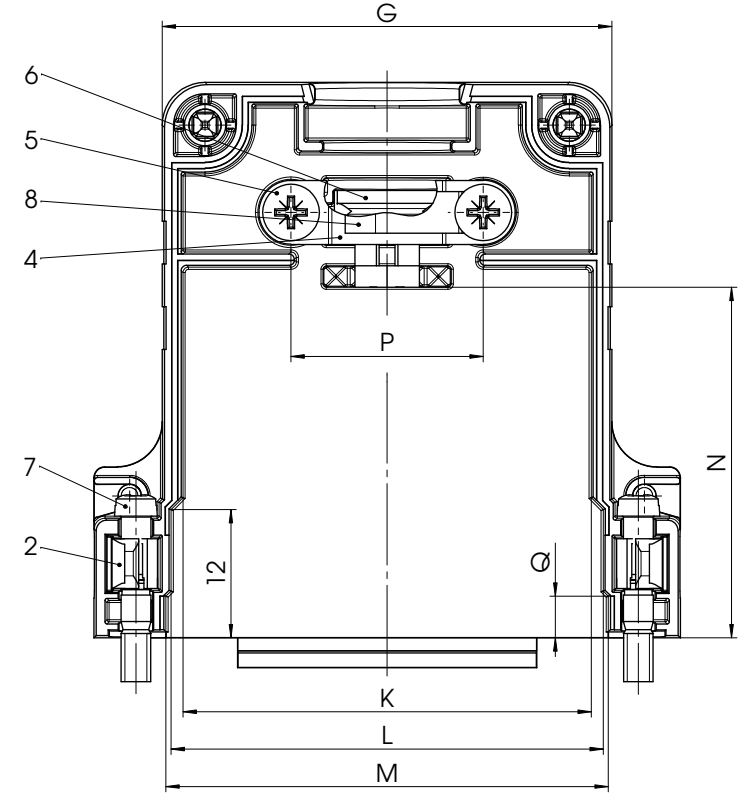
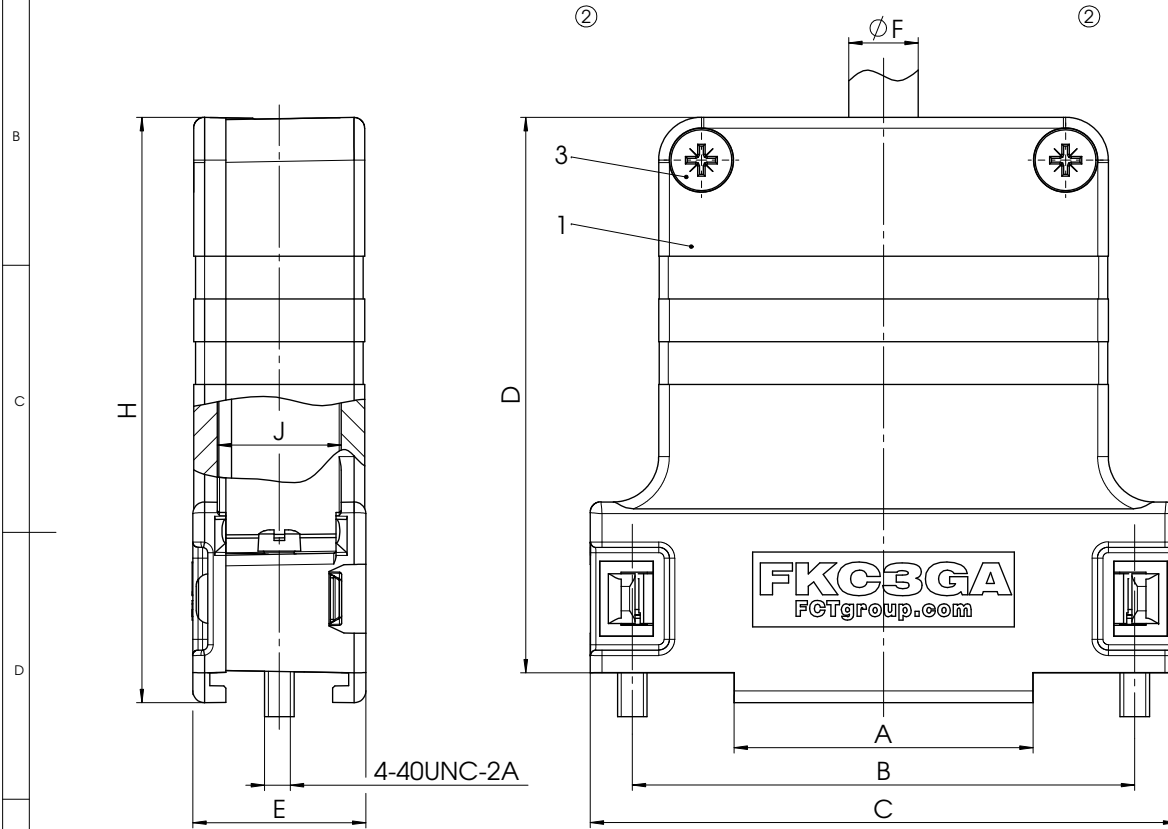

No.	St.	Part	Type	Description/Material	Surface plating/Colour/Class
8	1	Contact spring	Spring steel		blank
7	2	Locking screw	FVS1/5-K1163 4-40 / Steel		nickel plated
6	1	Strain relief	Polyester		nickel plated
5	2	Cable clamp screw	Case hardened steel		zinc plated
4	1	Cable clamp	Steel		tin plated
3	2	Shell screw	Steel		zinc plated
2	2	Catch spring	Polyester		black
1	1	Hood	FKC1-5GA / Polyester		nickel plated

① max. torque are 40 Ncm  
Hood is snapped together  
Part-No. 3, 4, 5, 6 and 8 not mounted

Measurement without tolerance acc. to ISO 2768-m		SCALE	TITLE	
		2:1	Plastic hood	
NAME / DATE				
DRAWN Gabriele.Wagner 28-04-2008				
CHECKED Gabriele.Wagner 02-07-2008				
FCT group fctgroup.com		DWG.NO.	REV.	
		FKC1-5GA	2	
2	02-07-2008	22263		
1	28-04-2008	22224		
REV.	DATE	CH.-NO.	PAGES	
			1	

COMMENT:  
ALL RIGHTS ARE RESERVED BY US FOR THIS DRAWING. WITHOUT OUR PRIOR CONSENT,  
THIS DRAWING IS NOT TO BE REPRODUCED, COPIED, TRANSMITTED, OR OTHERWISE  
AND IT ALSO MAY NOT BE IMPROPERLY USED BY THE RECEIVER, OR A THIRD PARTY.