

IDEAS GENERATED DRAWING, DO NOT CHANGE BY HAND

REV.	ECN. NO.	APPD.
A	HC-06-4986	Bruce Wu

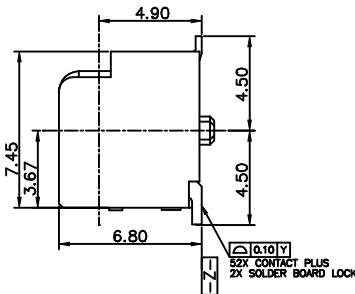
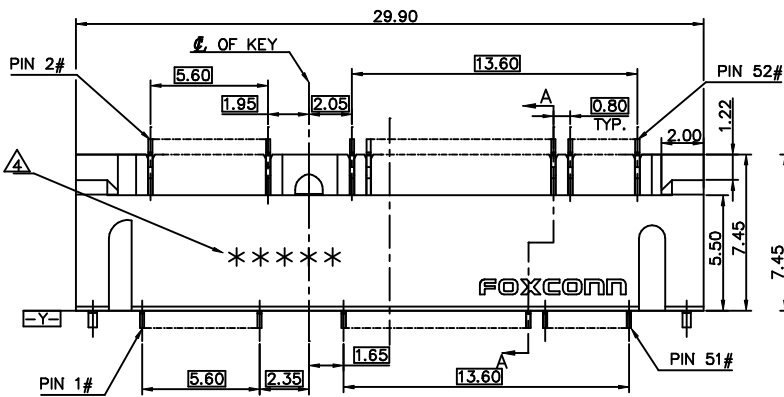
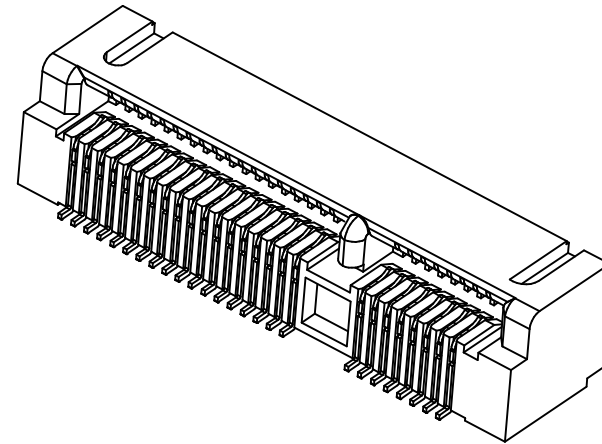
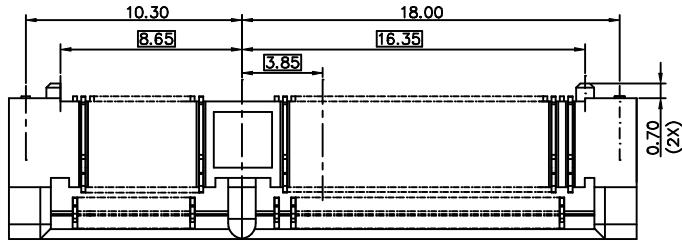
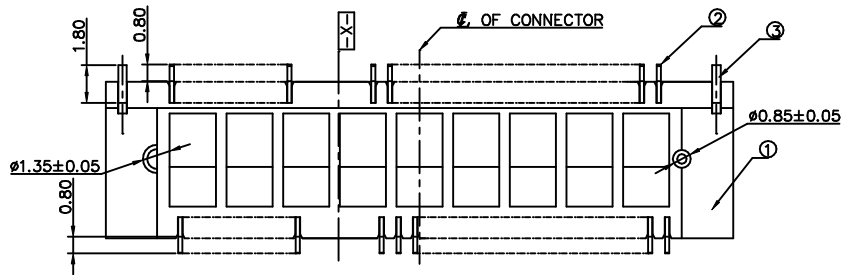

PART NO. DESCRIPTION: A S 0 B 2 * - S 6 8 * - * - *

MEMORY MODULE SOCKET
 HORIZONTAL TYPE
 SINGLE ROW
 NO. OF POS. B2= 52 POS.
 SMT
 CONTACT AREA PLATING
 GOLD PLATING

F=LEAD FREE
 4=SOFT TRAY
 7=TAPE & REEL
 N=CONNECTOR
 K=CLIP ONLY
 68=6.8mm HEIGHT
 SHORT BODY

CONNECTOR

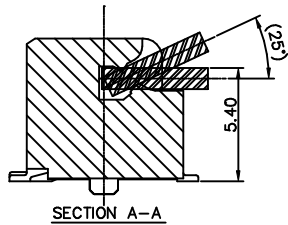

X.± 0.30	X°.±	UNITS	mm	NAME(INTENDED USE)	FOXCONN HON HAI PRECISION IND. CO.,LTD. TAIPEI, TAIWAN, R.O.C.
.X± 0.25	.X°.±	MAT'L		MINI PCI EXPRESS Connector	TITLE: CUSTOMER DRAWING
.XX± 0.15	.XX°.±	FINISH		PART NO.(INTENDED USE) ASOB22*-S68*-**	DWG NO.: 317-0000-1228
.XXX±	.XXX°.±	Q'TY		APPD: Bruce Wu 4/23'06 CHKD: Herry Yang 4/23'06 DR: Rechar.d.XIAO 4/21'06	SCALE SHEET REV. N/A 1/6 A
THESE DRAWINGS AND SPECIFICATIONS ARE THE PROPERTY OF HON HAI PRECISION IND. CO., LTD. AND SHALL NOT BE REPRODUCED, COPIED OR USED IN ANY MANNER WITHOUT THE PRIOR WRITTEN CONSENT OF HON HAI PRECISION IND. CO., LTD.					

IDEAS GENERATED DRAWING, DO NOT CHANGE BY HAND

REV.	ECN.	NO.	APPD.

A
B
C
D
E

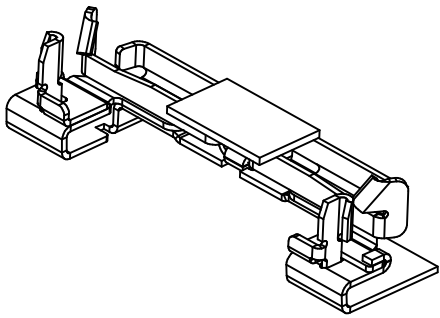
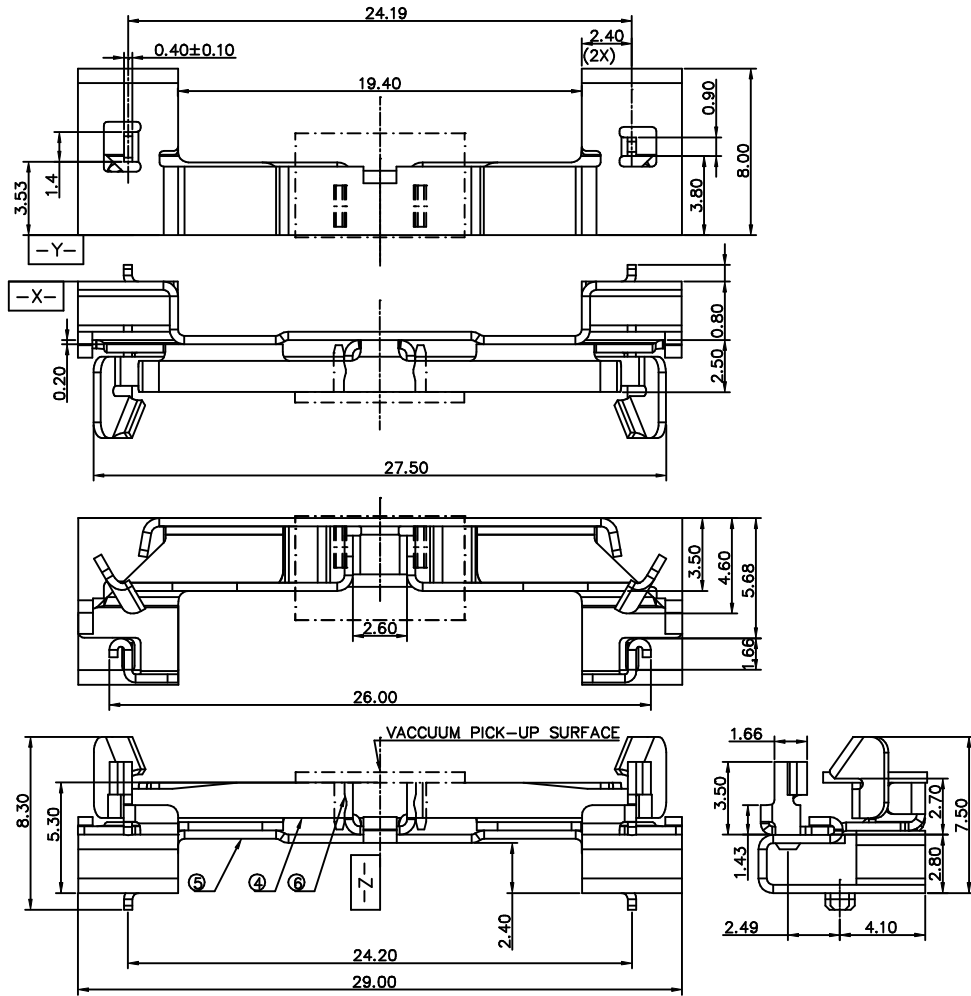

SPECIFICATIONS:

- ELECTRICAL CHARACTERISTICS:**
 - 1-1 CURRENT RATING: 0.75 A MAX per power contact.
 - 1-2 VOLTAGE RATING: 50 VAC per contact.
 - 1-3 LOW LEVEL CONTACT RESISTANCE: 55mΩ max. initial, ΔR =20mΩ max.
 - 1-4 INSULATION RESISTANCE: 500MΩ min. at 500 V DC.
 - 1-5 DIELECTRIC WITHSTANDING VOLTAGE: 300 V AC (RMS).
 - 1-6 INSERTION LOSS: f ≤1.25 GHz: ≤1dB; 1.25 <f≤3.75 GHz: ≤1.6x(f-1.25)+1dB
 - 1-7 RETURN LOSS: f ≤1.3GHz: ≤-12dB; 1.3<f≤2GHz: ≤-7dB; 2<f≤3.75GHz: ≤-4dB
 - 1-8 CROSSTALK NEXT: f≤1.25GHz: ≤-32dB; 1.25<f≤3.75GHz: ≤-(32-2.4x(f-1.25)) dB
 - 1-9 TEMPERATURE RISE VERSUS CURRENT: <30°C at rated current per EIA-364-70A, method 2.
- MECHANICAL CHARACTERISTICS:**
 - 2-1 DURABILITY: 50 mating/unmating cycles.
 - 2-2 MATING/UNMATING FORCE: 2.3 kgf max. per connector.
- ENVIRONMENTAL CHARACTERISTICS:**
 - 3-1 USEFUL FIELD LIFE: 5 years.
 - 3-2 OPERATING TEMPERATURE: -40°C TO +80°C.
 - 3-3 TEMPERATURE LIFE: Subject mated samples at 105±2°C for 120 hours per EIA-364-17, method A.
 - 3-4 THERMAL SHOCK: Subject mated samples to 10 cycles between -55 to 85°C per EIA-364-32C, condition I.
 - 3-5 CYCLIC TEMPERATURE & HUMIDITY: Subject mated samples to 24 cycles between 25°C at 80% RH to 65°C at 50% RH per EIA-364-31B.
 - 3-6 VIBRATION: Subject mated samples to 20 to 500 Hz, 3.1 g RMS random excitation of 15 min. in each of the 3 axes and no discontinuity >1μs is found per EIA-364-28D, test condition VII, test condition letter D.
 - 3-7 MECHANICAL SHOCK: Subject mated samples to 50% half-sine excitation of 11 ms duration and no discontinuity >1μs is found per per EIA-364-27B, condition A.
 - 3-8 MIXED FLOWING GAS: Subject mated samples for 7 days per EIA-364-65, class IIA.
 - 3-9 THERMAL DISTURBANCE: Subject mated samples to 10 cycles between 15 to 85°C.
- PLEASE CONTACT FOXCONN SALES REPRESENTATIVE TO VERIFY PRODUCT DETAILS & AVAILABILITY.

⑥	CAP	1	THERMOPLASTIC	UL94V-0, IVORY COLOR(IN ORDER TO PICK-UP,TAKE AWAY AFTER ASSEMBLY)
⑤	CLIP(2)	1	STAINLESS STEEL	Pd PLATING OVER SOLDER PAD AREA
④	CLIP(1)	1	STAINLESS STEEL	NO PLATING
③	BOARD LOCK	2	COPPER ALLOY	PURE TIN OVER ALL
②	CONTACT	52	PHOSPHOR BRONZE	NICKEL UNDER PLATING GOLD PLATING AT CONTACT AREA
①	HOUSING	1	THERMOPLASTIC	UL94V-0, IVORY COLOR
ITEM	DESCRIPTION	Q'TY	MATERIAL	TREATMENT

x.± 0.30	x'±	UNITS	mm	NAME(INTENDED USE)	FOXCONN HON HAI PRECISION IND. CO.,LTD. TAIPEI, TAIWAN, R.O.C.
.x± 0.25	.x'±	MAT'L		MINI PCI EXPRESS Connector	
.xx± 0.15	.xx'±	FINISH		PART NO.(INTENDED USE)	TITLE:
.xxx±	.xxx'±	Q'TY		ASOB22*-S68*-**	CUSTOMER DRAWING
THESE DRAWINGS AND SPECIFICATIONS ARE THE PROPERTY OF HON HAI PRECISION IND. CO., LTD. AND SHALL NOT BE REPRODUCED, COPIED OR USED IN ANY MANNER WITHOUT THE PRIOR WRITTEN CONSENT OF HON HAI PRECISION IND. CO., LTD.				APPD:	DWG NO.:
				Bruce Wu 4/23'06	317-0000-1228
				CHKD:	SCALE
				Herry Yang 4/23'06	SHEET
				DR: Recharh.XIAO 4/21'06	REV.
					N/A
					2/6
					A

A
B
C
D
E

1 2 3 4 5 6 7

IDEAS GENERATED DRAWING, DO NOT CHANGE BY HAND

REV.	ECN.	NO.	APPD.

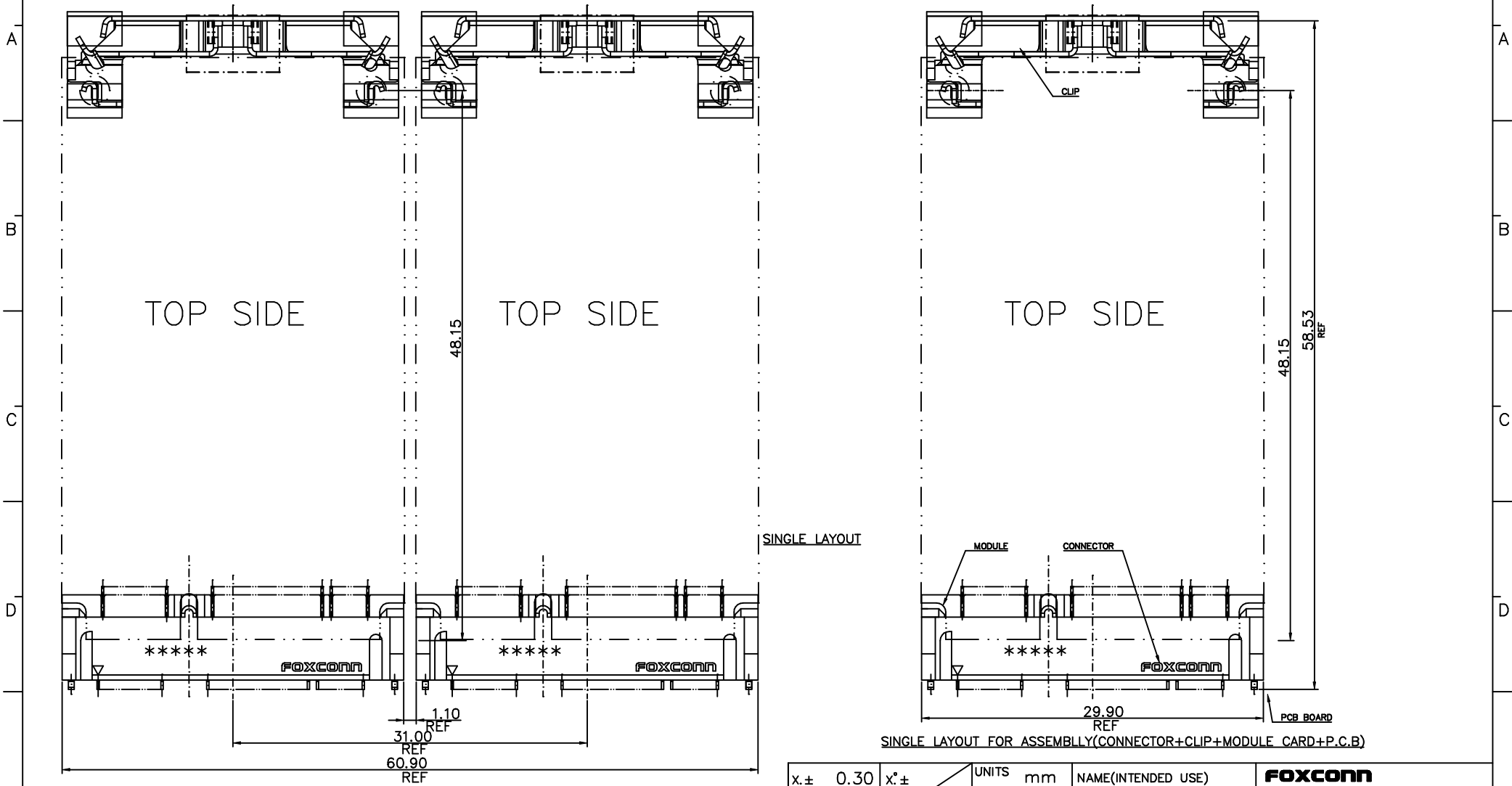

x.± 0.30	x'.±	UNITS mm	NAME(INTENDED USE)	FOXCONN HON HAI PRECISION IND. CO.,LTD. TAIPEI, TAIWAN, R.O.C.
.x± 0.25	.x'±		MINI PCI EXPRESS Connector	
.xx± 0.15	.xx'±	MAT'L	PART NO.(INTENDED USE)	TITLE:
.xxx±	.xxx'±		ASOB22*-S68*-**	CUSTOMER DRAWING
		FINISH	APPD:	DWG NO.:
				Bruce Wu 4/23'06
		Q'TY	CHKD:	
				Herry Yang 4/23'06
			DR:	
			Rechard.XIAO 4/21'06	
			SCALE	SHEET
			N/A	3/6
			REV.	
				A

THESE DRAWINGS AND SPECIFICATIONS ARE THE PROPERTY OF HON HAI PRECISION IND. CO., LTD. AND SHALL NOT BE REPRODUCED, COPIED OR USED IN ANY MANNER WITHOUT THE PRIOR WRITTEN CONSENT OF HON HAI PRECISION IND. CO., LTD.

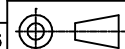

IDEAS GENERATED DRAWING, DO NOT CHANGE BY HAND

REV.	ECN.	NO.	APPD.

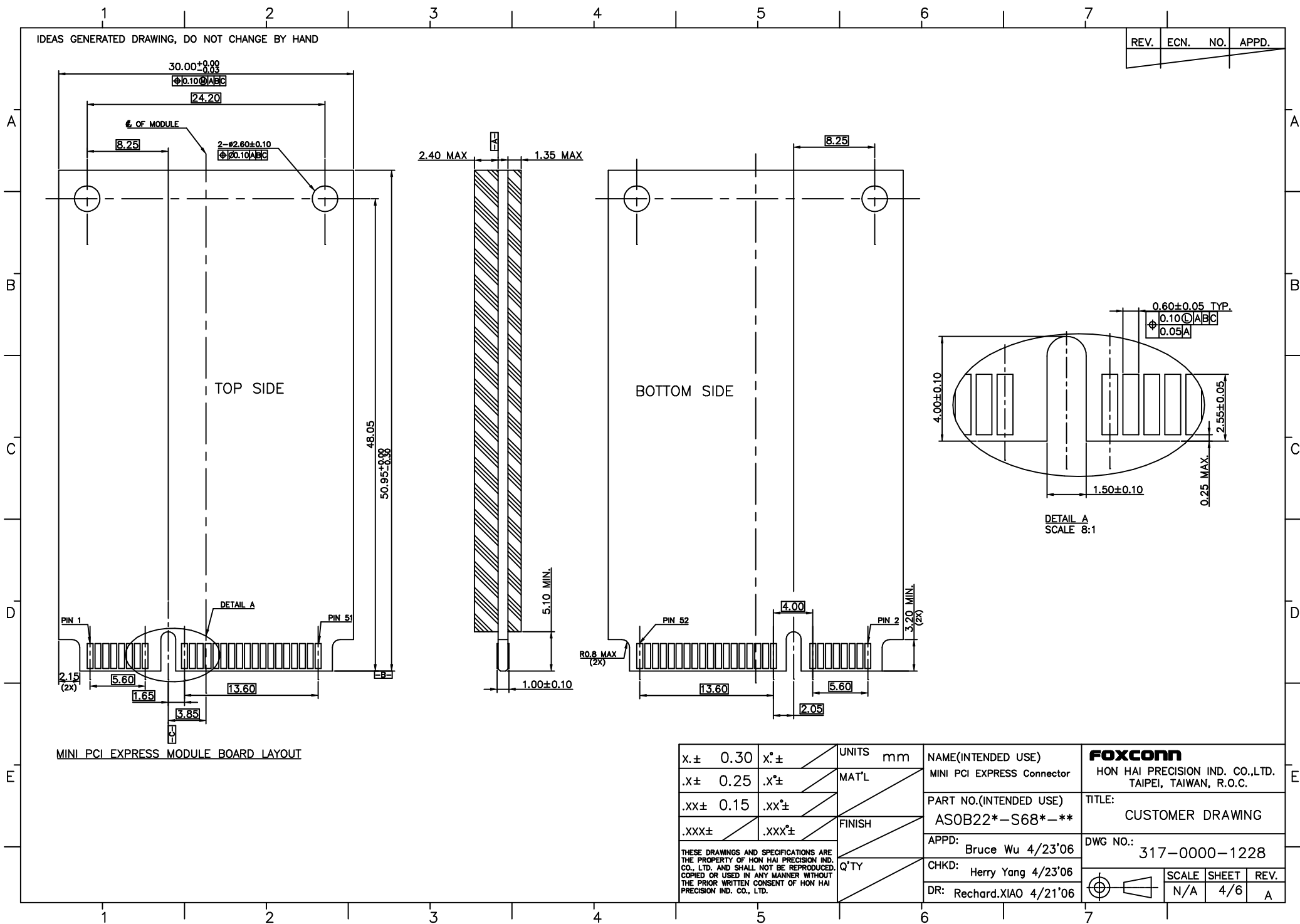

MINI PCI EXPRESS MODULE BOARD LAYOUT

x.± 0.30	x°.±	UNITS	mm	NAME(INTENDED USE)	FOXCONN	
.x± 0.25	.x°±	MAT'L		MINI PCI EXPRESS Connector	HON HAI PRECISION IND. CO.,LTD. TAIPEI, TAIWAN, R.O.C.	
.xx± 0.15	.xx°±	FINISH		PART NO.(INTENDED USE)	TITLE: CUSTOMER DRAWING	
.xxx±	.xxx°±	Q'TY		ASOB22*-S68*-**	DWG NO.:	
<p>THESE DRAWINGS AND SPECIFICATIONS ARE THE PROPERTY OF HON HAI PRECISION IND. CO., LTD. AND SHALL NOT BE REPRODUCED, COPIED OR USED IN ANY MANNER WITHOUT THE PRIOR WRITTEN CONSENT OF HON HAI PRECISION IND. CO., LTD.</p>				APPD: Bruce Wu 4/23'06	317-0000-1228	
				CHKD: Herry Yang 4/23'06		
				DR: Rechar.d.XIAO 4/21'06		
				SCALE	SHEET	REV.
				N/A	4/6	A

IDEAS GENERATED DRAWING, DO NOT CHANGE BY HAND

REV.	ECN.	NO.	APPD.

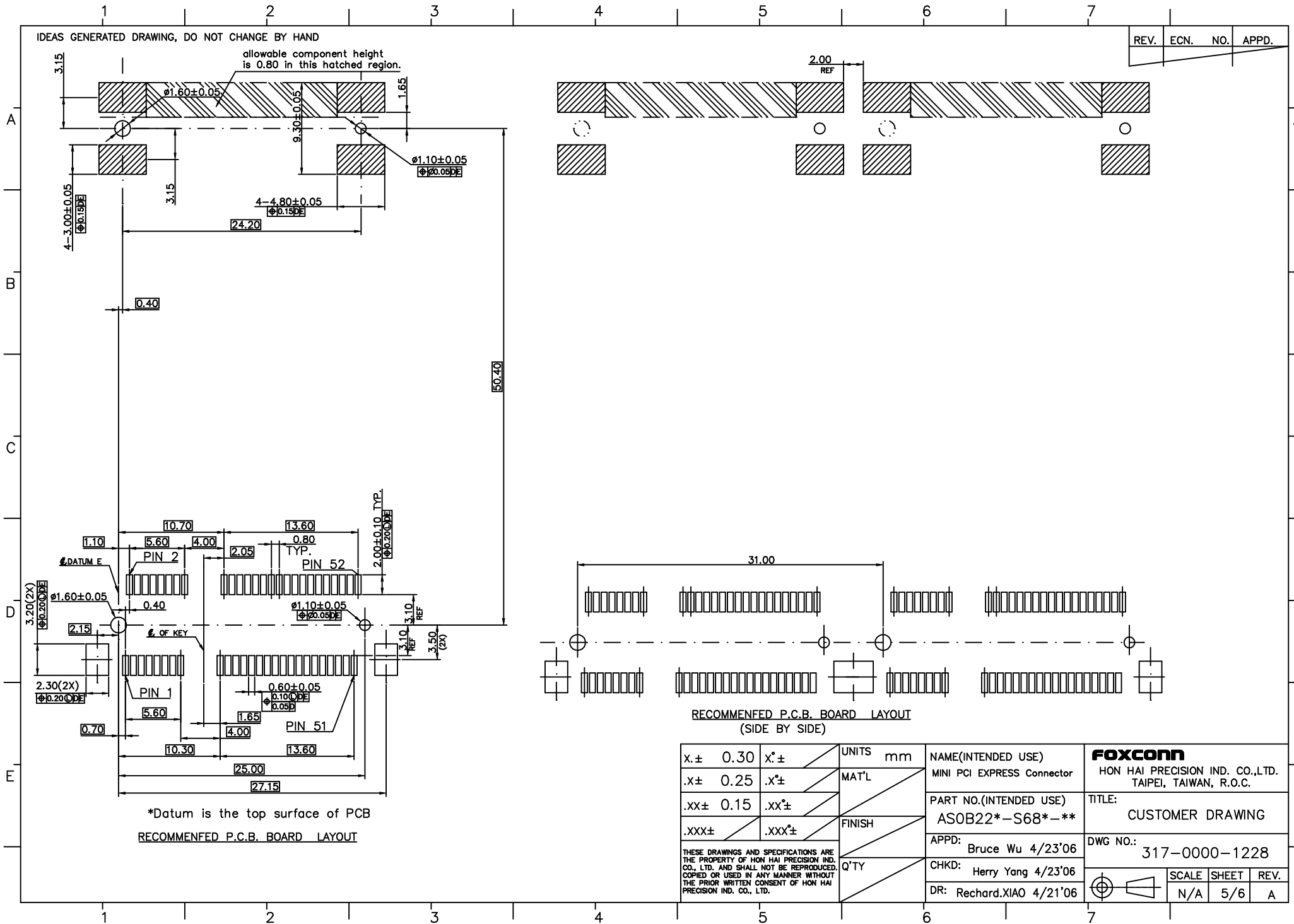

*Datum is the top surface of PCB
RECOMMENDED P.C.B. BOARD LAYOUT

RECOMMENDED P.C.B. BOARD LAYOUT
(SIDE BY SIDE)

x.± 0.30	x°.±	UNITS	mm	NAME(INTENDED USE)	FOXCONN HON HAI PRECISION IND. CO.,LTD. TAIPEI, TAIWAN, R.O.C.
.x± 0.25	.x°.±		MAT'L	MINI PCI EXPRESS Connector	
.xx± 0.15	.xx°.±	FINISH		PART NO.(INTENDED USE)	TITLE:
.xxx±	.xxx°.±		Q'TY		AS0B22*-S68*-**
THESE DRAWINGS AND SPECIFICATIONS ARE THE PROPERTY OF HON HAI PRECISION IND. CO., LTD. AND SHALL NOT BE REPRODUCED, COPIED OR USED IN ANY MANNER WITHOUT THE PRIOR WRITTEN CONSENT OF HON HAI PRECISION IND. CO., LTD.				APPD: Bruce Wu 4/23'06	DWG NO.:
				CHKD: Herry Yang 4/23'06	317-0000-1228
				DR: RecharD.XIAO 4/21'06	SCALE SHEET REV.
				⊕	N/A 5/6 A

IDEAS GENERATED DRAWING, DO NOT CHANGE BY HAND

REV.	ECN.	NO.	APPD.

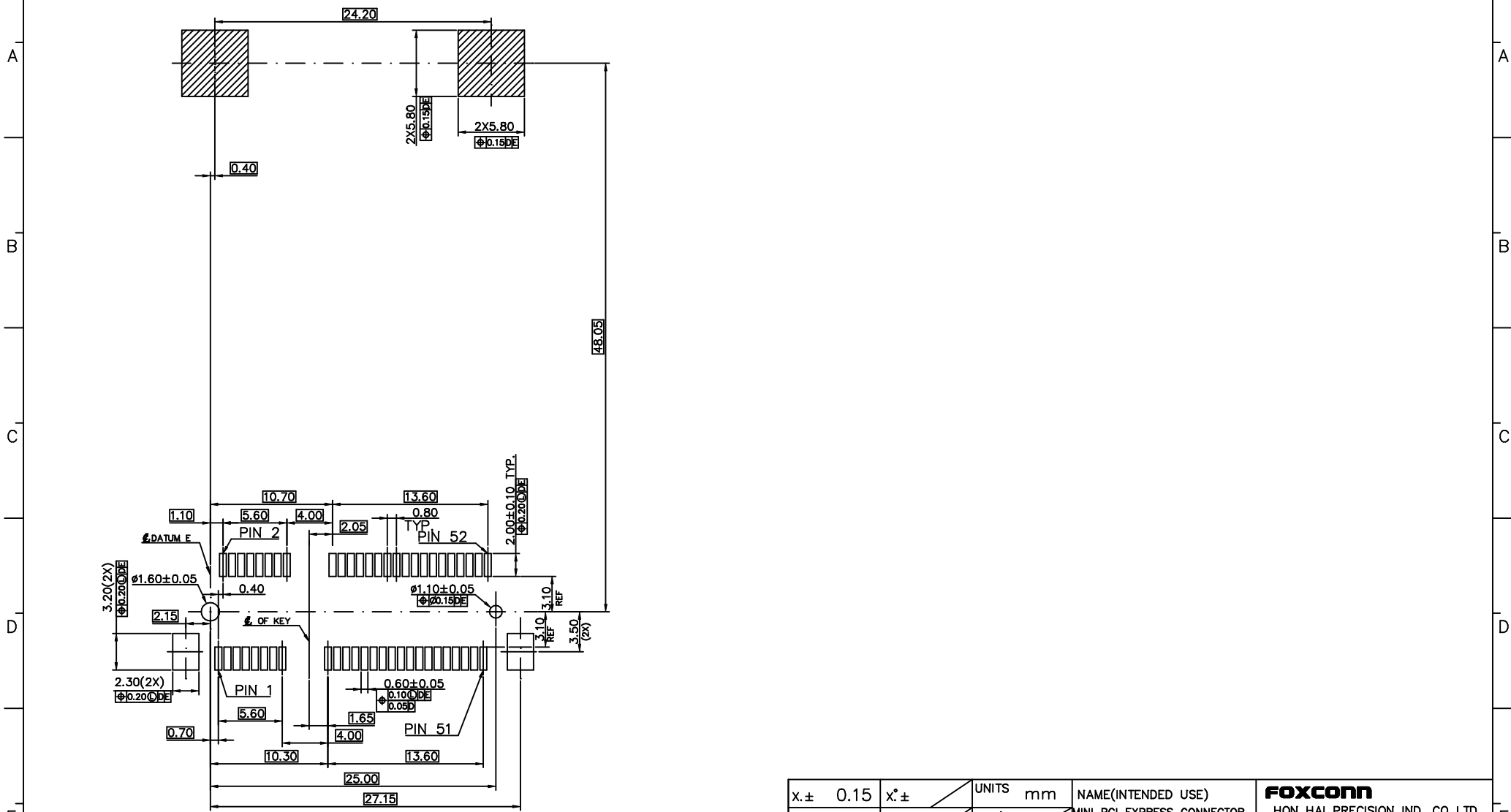

*Datum is the top surface of PCB
 RECOMMENED P.C.B. BOARD LAYOUT(WITH NUT)

X.± 0.15	X°.±	UNITS	mm	NAME(INTENDED USE)	FOXCONN HON HAI PRECISION IND. CO.,LTD. TAIPEI, TAIWAN, R.O.C.
.X± 0.10	.X°.±	MAT'L		MINI PCI EXPRESS CONNECTOR	
.XX± 0.05	.XX°.±	FINISH		PART NO.(INTENDED USE)	TITLE:
.XXX±	.XXX°.±	Q'TY		ASOB22*-S68*-**	CUSTOMER DRAWING
THESE DRAWINGS AND SPECIFICATIONS ARE THE PROPERTY OF HON HAI PRECISION IND. CO., LTD. AND SHALL NOT BE REPRODUCED, COPIED OR USED IN ANY MANNER WITHOUT THE PRIOR WRITTEN CONSENT OF HON HAI PRECISION IND. CO., LTD.				APPD: Bruce Wu 4/23'06	DWG NO.: 317-0000-1228
				CHKD: Herry Yang 4/23'06	
				DR: RecharD.XIAO 4/21'06	
					SCALE SHEET REV.
				N/A	6/6 A