



佳承精工股份有限公司
CHIA CHERNE INDUSTRY CO.,LTD.

承認書
APPROVAL SHEET

GP

品名:	COOLER	
DESCRIPTION	_____	
規格:	JYCC501A	
TYPE/MODEL	(First Version Valid From 03/30/07)	
客戶:	S.C	
BUYER	_____	
日期:	_____	
DATE	_____	
審核	確認	經辦
APPROVER	CHECKER <i>John</i>	HANDLER <i>Tony</i>

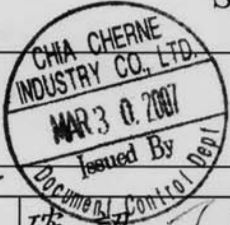

客戶承認印 APPROVAL SIGNATURES				
審核 APPROVER	確認 CHECKER	主辦 HANDLER	結論 CONCLUSION	印章 SIGNATURE

NO. 55, Alley 121, Lane 175, Kousheng Rd., Changhua City, Taiwan
彰化市國聖路 175 巷 121 弄 55 號
TEL. +886 4 732 3090 FAX. +886 4 738 3155
<http://www.cooljag.com>

JYCC501A



Application	INTEL LGA -775
Specification	
Weight	~ 332g
Dimension	115L×115W×38.5H (mm)
Heat sink	
Model	JYH501A
Material	AL6063 & Cu core
Fan	
Rated Voltage	DC12V
Rated Current	0.11A
Rated Speed	2400RPM ±10%

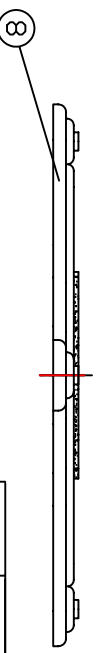
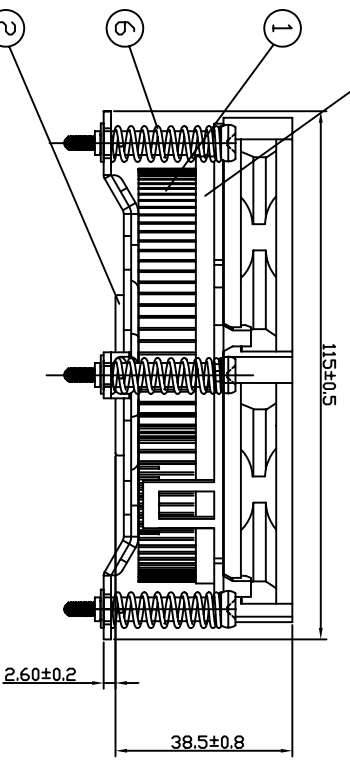
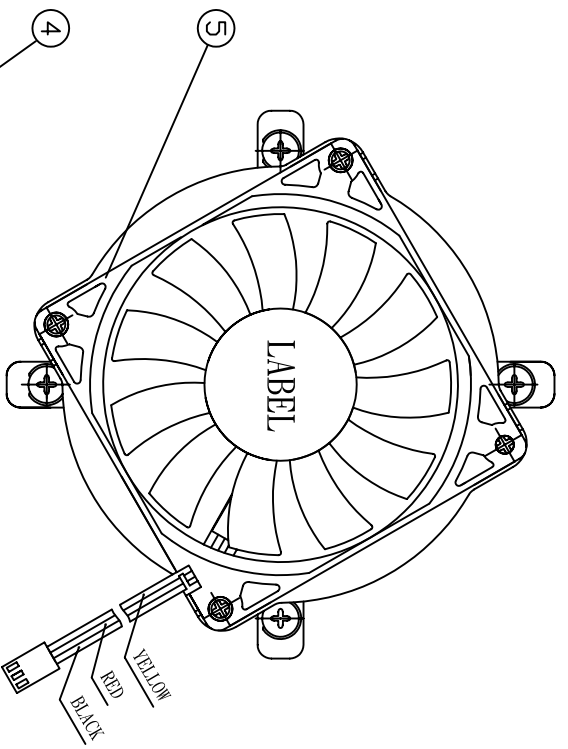

BILL OF MATERIAL			
1	HEATSINK	Ø90*16*104FIN	1
2	CU CORE	Ø35*21L	1
3	Bracket	115*115*7.6	1
4	Fan Cover	Ø95*6H	1
5	Fan	80*80*15mm	1
6	SPRING&SCREW	SAE1018-SWC(NIKEL)	4
7	GREASE	DOWCORNING SC102 (Ø33*0.25)	1
8	BACK PLATE	JAT055Jfor LGA775	1

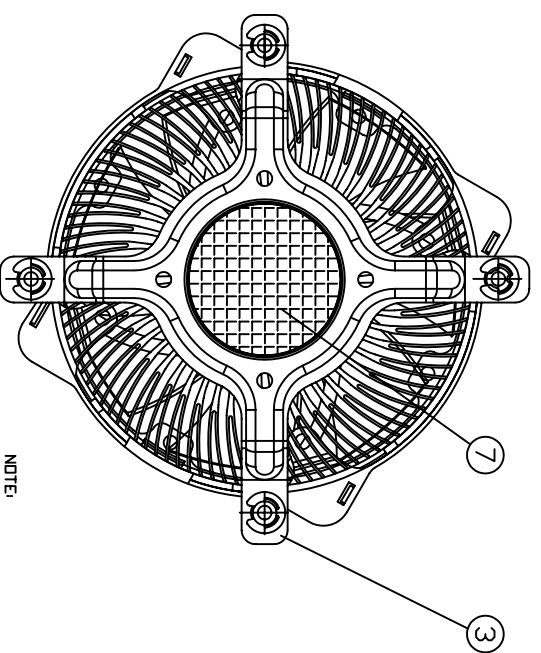

NOTE:
 1. DEBURR AND BREAK ALL SHARP EDGES.
 2. BOTTOM DIAGONAL FLATNESS < 0.005 mm.

MODEL		NAME		REV.		DESCRIPTION		SIGNDATE	
JYCC501A		COOLER		—					
DRN	Tony	03/30	MATERIAL	—	—				
DSN	Kathy	03/30	FINISH	—	—				
CKD	Richard	03/30							
APPD	Kevin	03/30							

Cooling
 CHIA CHERNE INDUSTRY CO.,LTD

DRAWING NO.	JYCC501A
DIM IN	mm
SHEET	1 OF 1

SUNON

SPECIFICATION FOR APPROVAL

CUSTOMER :
MOTOR TYPE : 
DESCRIPTION : MagLev Motor Fan
DIMENSIONS : 80X80X15 mm
MODEL : KDE1208PHV3
P/N : 13.MS.B1588.AF.GN
SUNON SPEC. NO. : D08024470G-00
APPROVAL NO. :
APPROVED BY :

(AUTHORIZED)

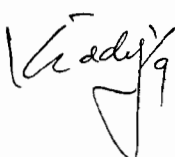
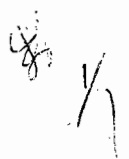
DRAWN	Rain 1/7	CHECKED		APPROVED		SPEC.NO	D08024470G-00
						ISSUE DATE	01.07.2006
						EDITION	0
						REVISION DATE	
						E.SPEC	EM80202.B1588

建準電機工業股份有限公司

SUNONWEALTH ELECTRIC MACHINE INDUSTRY CO., LTD.

12FL., 120 CHUNG CHENG 1ST RD.,

TEL:886-7-7163069(41 LINES)

KAOHSIUNG, TAIWAN, R. O. C.

FAX:886-7-7163086-89

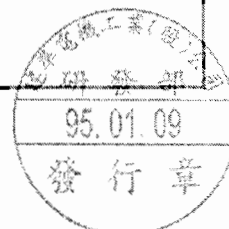

DC BRUSHLESS FAN
MODEL : KDE1208PHV3
P/N : 13.MS.B1588.AF.GN

CHARACTERISTICS

- 1. Motor Design** : DC brushless 4 pole motor design.
- 2. Insulation Resistance** : More than 10M ohm between internal stator and lead wire(+) measured at DC 500V.
- 3. Dielectric Strength** : Applied AC 500V for one minute or AC 600V for 2 seconds between housing and lead wire(+)
- 4. Noise Level** : Measured in a semi-anechoic chamber with background noise level below 15 dB(A). The fan is running in free air with the microphone at a distance of one meter from the fan intake.
- 5. Input Power, Current & Speed** : Measured after continuous 10 minute operation at rated voltage in clean air, and at ambient temperature of 25 degrees C.
- 6. Tolerance** : $\pm 15\%$ on rated power and current.
- 7. Air Performance** : Measured by a double chamber. The values are recorded when the fan speed has stabilized at rated voltage.

建準電機工業股份有限公司
 SUNONWEALTH ELECTRIC
 MACHINE INDUSTRY CO., LTD.

SPEC.NO	D08024470G-00	REVISION DATE
ISSUE DATE	01. 07. 2006	E D I T I O N
P A G E	2 O F 11	



SPECIFICATIONS

MODEL : KDE1208PHV3

P/N : 13.MS.B1588.AF.GN

- 1-1. Rated Voltage : 12 VDC**
- 1-2. Operating Voltage Range : 5~13.8 VDC**
- 1-3. Starting Voltage : 5 VDC (25 deg. C POWER ON/OFF)**
- 1-4. Rated Speed : 2400 RPM ± 10%**
- 1-5. Air Delivery : 32 CFM**
- 1-6. Static Pressure : 0.09 Inch-H₂O**
- 1-7. Rated Current : 0.11 AMP**
- 1-8. Rated Power : 1.3 WATTS**
- 1-9. Noise Level : 28 dB(A)**
- 1-10. Direction of Rotation : Counter-clockwise viewed from front of fan blade**
- 1-11. Operating Temperature : -10 to +70 deg. C**
- 1-12. Storage Temperature : -40 to +70 deg. C**
- 1-13. Bearing System : Vapo bearing system**
- 1-14. Weight : 68 g**
- 1-15. Safety : UL/CUR/TUV/CE Approvals**
- 1-16. Vibration : Vibration of acceleration 1.5G and frequency 5~50~5Hz is applied in all 3 directions(X,Y,Z), in cycles of 1 minute each, for a total vibration time of 30 minutes.**
- 1-17. Locked Rotor Protection : Automatic Restart Capability**
 Note: In a situation where the fan is locked by an external force while the electricity is on, an increase in coil temperature will be prevented by temporarily turning off the electrical power to the motor. The fan will automatically restart when the locked rotor condition is released.

建準電機工業股份有限公司 SUNONWEALTH ELECTRIC MACHINE INDUSTRY CO., LTD.	SPEC.NO	D08024470G-00	REVISION DATE
	ISSUE DATE	01. 07. 2006	E D I T I O N
	P A G E	3 OF 11	



MODEL : KDE1208PHV3

P/N : 13.MS.B1588.AF.GN

PERFORMANCE CURVES

**STATIC
PRESSURE**

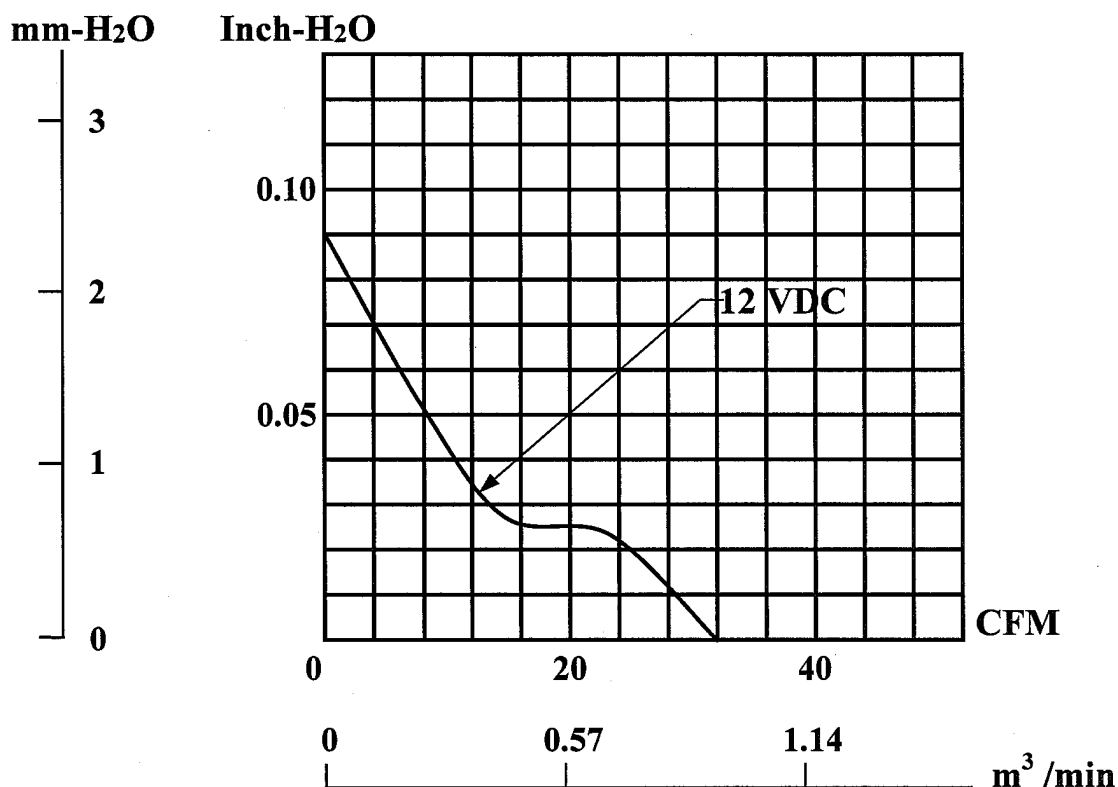

建準電機工業股份有限公司
SUNONWEALTH ELECTRIC
MACHINE INDUSTRY CO., LTD.

SPEC.NO	D08024470G-00	REVISION DATE
ISSUE DATE	01.07.2006	EDITION
PAGE	4 OF 11	



MATERIAL

- 2-1. Frame : Thermoplastic PBT of UL 94V-0
- 2-2. Impeller : Thermoplastic PBT of UL 94V-0
- 2-3. Bobbin : Thermoplastic PBT of UL 94V-0
- 2-4. Lead Wire : UL1007,24 awg,+RED,-BLACK
UL1007,24 awg,YELLOW:3rd Wire

DIMENSIONS

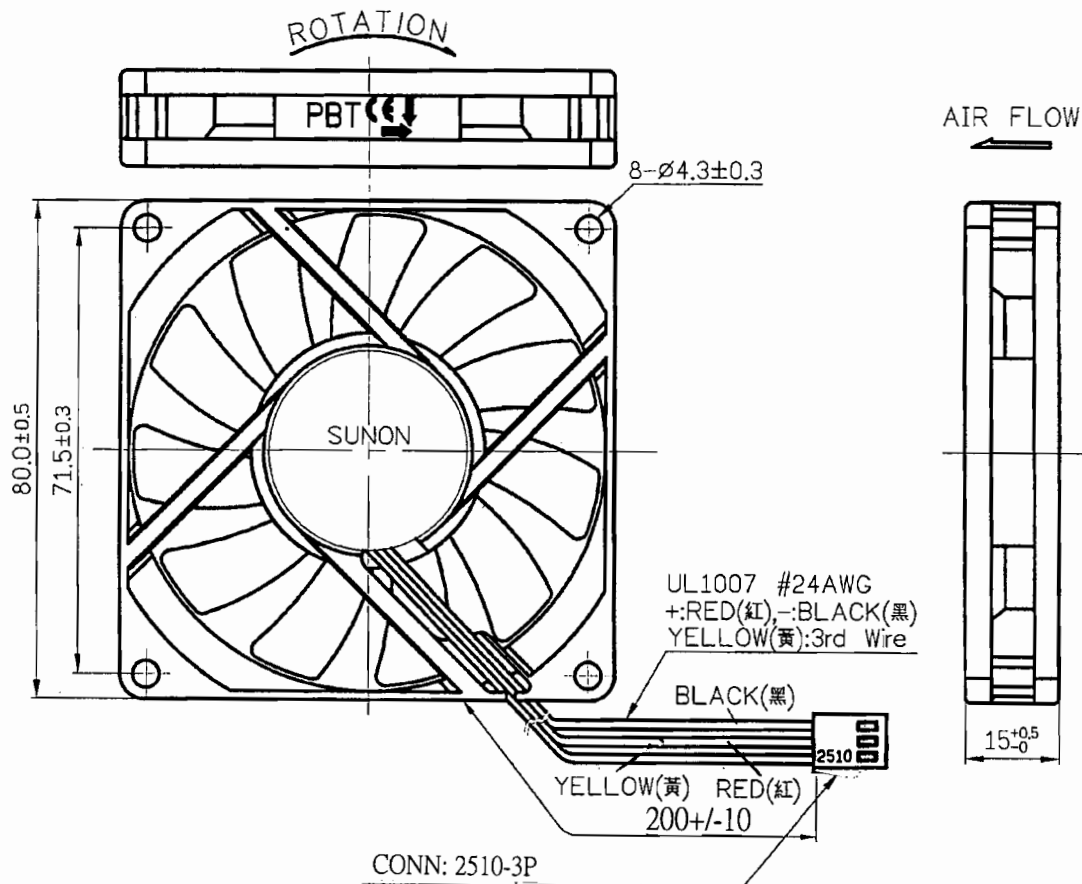

1. Air Flow Direction: Toward label side.
2. Best Mounting Direction: Any orientation.

UNITS: mm

建準電機工業股份有限公司
SUNONWEALTH ELECTRIC
MACHINE INDUSTRY CO., LTD.

SPEC.NO	D08024470G-00	REVISION DATE	
ISSUE DATE	01. 07. 2006	EDITION	0
PAGE	5 OF 11		

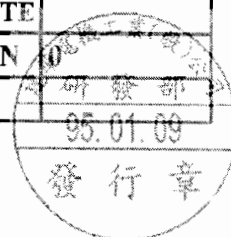

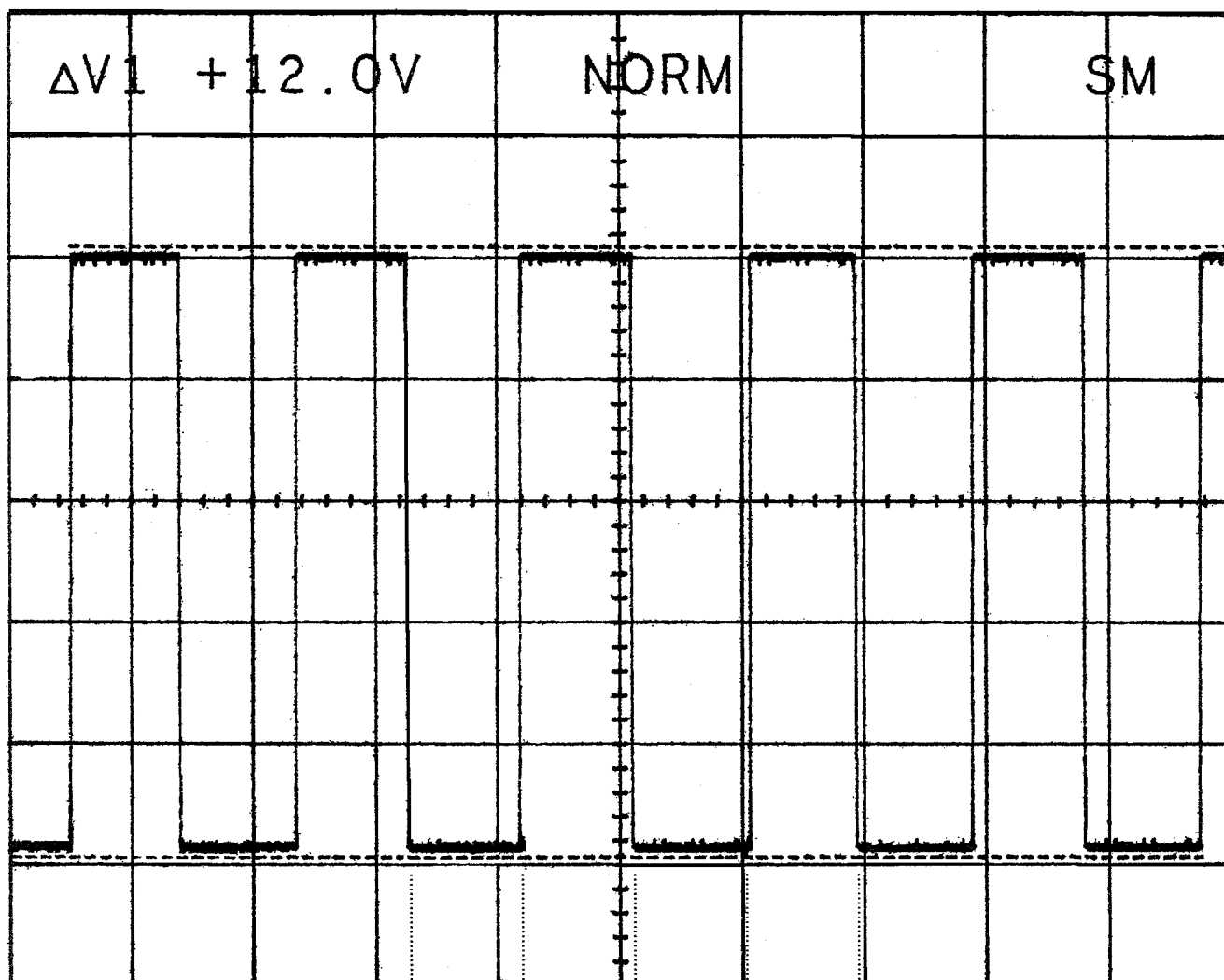

T_1 T_2 T_3 T_4
 ←—————→
 T=1 Rotation

$T = T_1 + T_2 + T_3 + T_4 = (1 \text{ Rotation})$

$T_1 = T_2 = T_3 = T_4 = \frac{60}{4 \times \text{rpm}}$

建準電機工業股份有限公司
 SUNONWEALTH ELECTRIC
 MACHINE INDUSTRY CO., LTD.

SPEC.NO	D08024470G-00	REVISION DATE
ISSUE DATE	01. 07. 2006	EDITION
PAGE	6 OF 11	



FAN 3rd WIRE SIGNAL

Fan with driver IC:

● R Type (Rotation Detector)

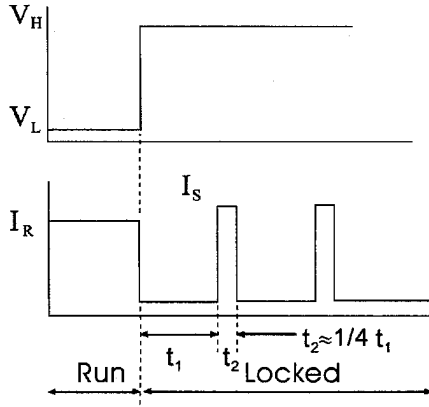

3rd wire signal :

Run :V_L
Locked :V_H

t₁:Locked protection by cut-off run current (I_R)
t₂:Auto-restart by sending starting current (I_S)

● F Type (Frequency Generator)

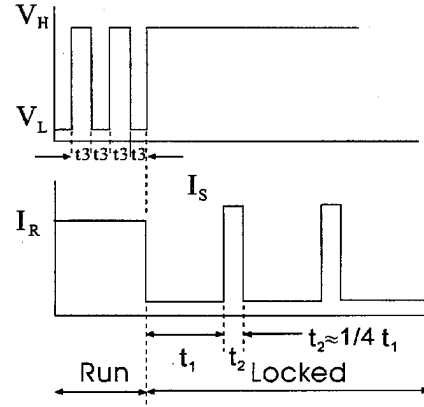

3rd wire signal :

Run :Square Wave
Locked :V_H

t₃:F Type has open collector circuit designed for rpm measurement.

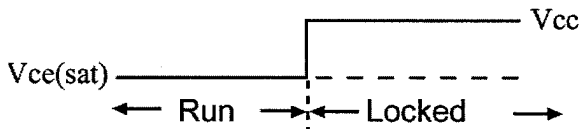
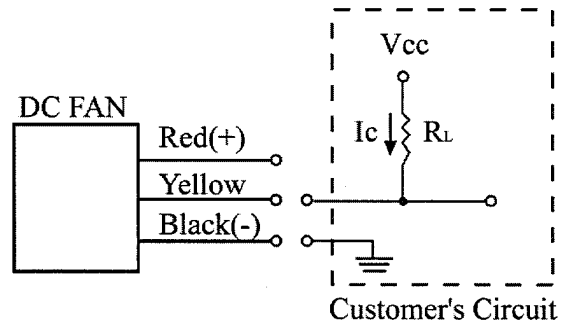
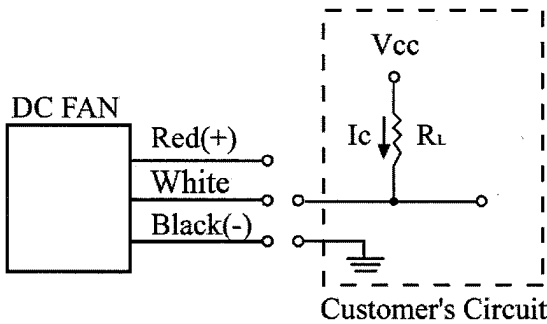

V_{cc}=+30V max
I_c=10mA max
$$I_c = \frac{V_{cc}}{R_L}$$

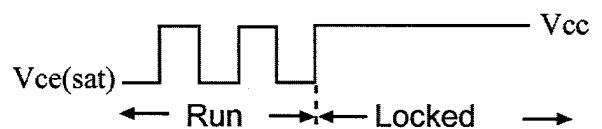

V_{cc}=+30V max
I_c=10mA max
$$I_c = \frac{V_{cc}}{R_L}$$



Notes

I . Safety

- 1.SUNON will not guarantee this product if your application exceeds the limitations outlined in this specification.
- 2.There is no thermo-protector installed in this product, such as thermo-fuse, or current-fuse or thermo-protector. There may be smoking, ignition, or electric shock by insulation degradation in cases of motor lock, motor lead short circuit, overload, over voltage, and/or other failure. Please add the protection circuit to your product.
- 3.There is no reverse-connection prevention diode of VDC (+) and GND (-) installed in this product. Therefore, if VDC(+) and GND(-) are reverse connected, it may cause smoking, ignition, and/or destruction, although these conditions may not manifest immediately. We recommend that a protection device be installed on your product when there is a possibility of reverse-connection.
- 4.Please verify that this product is being installed and used in compliance with all safety standards. Please inform SUNON of any safety concerns prior to releasing your product to production.
- 5.Please handle and install this product carefully. Hitting or dropping this product may cause damage.
- 6.Please do not damage this product including coil and lead wires while installing or wiring. There may be smoking or fire.
- 7.Sunon doesn't suggest customers to use power or ground PWM to control the fan speed, if necessary, we need to do the special design for the application.

建準電機工業股份有限公司 SUNONWEALTH ELECTRIC MACHINE INDUSTRY CO., LTD.	SPEC.NO	D08024470G-00	REVISION DATE
	ISSUE DATE	01. 07. 2006	E D I T I O N
	P A G E	8 O F 11	



Notes

II . Specification modification

- 1.SUNON offers engineering assistance on fan installation and cooling system design.
- 2.Any change to the parameters specified in this document will be determined by mutual agreement between both parties. Parameters which are not specified in this specification will be identical to the final sample which has been approved by your company.
- 3.Product will be shipped in accordance with this specification unless Sunon has been previously notified of parameters requiring exception.
- 4.Parameters modified by mutual consent will be incorporated in this specification.
- 5.Please notify SUNON in advance of any modification to your product or new application for this fan which may require a review of this specification.

建準電機工業股份有限公司 SUNONWEALTH ELECTRIC MACHINE INDUSTRY CO., LTD.	SPEC.NO	D08024470G-00	REVISION DATE
	ISSUE DATE	01. 07. 2006	E D I T I O N
	P A G E	9 O F 11	

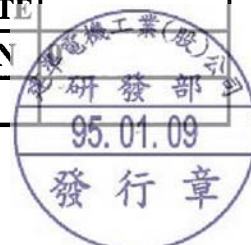

Notes

III . Other

1. When building your device, please examine thoroughly any variation of EMC, temperature rise, life data, quality, etc. of this product by shock/drop/vibration testing, etc. If there are any problems or accidents in connection with this product, it should be mutually discussed and examined.
2. Fan holders or bearings may be damaged if touched with fingers or other objects. Additionally, static electricity (ESD) may damage the internal circuits. Please handle this product carefully.
3. Please avoid operating SUNON's product in poisonous material (organic silicon, cyanogens, formalin, phenol, etc.) or corrosive gas environments (H₂S, SO₂, NO₂, Cl₂, etc).
4. SUNON does not warrant performance safety against accidents caused by dust, water, droplets, dew, bugs, etc.
5. Please advise us in advance if you require documents for export.
6. Improper mounting may cause harsh resonance, vibration, and noise. Please mount securely.
7. Safety is a top priority. Please furnish guard accessories to prevent injury to personnel.
8. Unless otherwise noted, all tests are conducted at 25°C ambient temperature and 65% relative humidity.
9. Always ensure that fans are stored according to the storage temperatures specified. Do not store in a high humidity environment. If the fans are stored for more than 6 months, SUNON recommends functional testing before using.
10. SUNON reserves the right to use components with equivalent specifications from multiple sources.

建準電機工業股份有限公司 SUNONWEALTH ELECTRIC MACHINE INDUSTRY CO., LTD.	SPEC.NO	D08024470G-00	REVISION DATE
	ISSUE DATE	01. 07. 2006	E D I T I O N
	P A G E	10 OF 11	

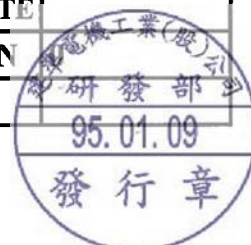

Declaration of RoHS

Control declaration of environment- related substances/ materials

1. In accordance with the Restriction of Hazardous Substances (RoHS) Directive, Sunon product with P/N: GN models have complied with law and discipline not to employ the forbidden substances, and restrict the allowable concentration of some limited substances deliberately in our components.

No	Substance	Criteria
1	Halogens & its compounds (Substances depleting the ozone layer)	Forbidden
2	Chlorinated Organic Solvent	Forbidden
3	Plastic (Frame, Impeller, wire harness, etc.)	<100ppm
	Solder	<1000ppm
	Iron Alloy	<3500ppm
	Aluminium Alloy	<4000ppm
	Copper Alloy	<4wt%
4	Solder	<20ppm
	Parts composed of metals containing zinc (e.g. brass, zinc for die casting)	<100ppm
	Plastic	<5ppm
5	PBB and PBDE Category	Forbidden
6	PCB and PCT Category	Forbidden
7	CP	Forbidden
8	Mirex	Forbidden
9	PCN category	Forbidden
10	Hexavalent Chromium Compounds	<100ppm
11	Mercury and its compounds	Forbidden
12	Asbestos	Forbidden
13	Organic Tin Compounds	Forbidden
14	Azo Compounds	Forbidden

建準電機工業股份有限公司 SUNONWEALTH ELECTRIC MACHINE INDUSTRY CO., LTD.	SPEC.NO	D08024470G-00	REVISION DATE	
	ISSUE DATE	01.07.2006	EDITION	0
	PAGE	11 OF 11		



A

B

C

D

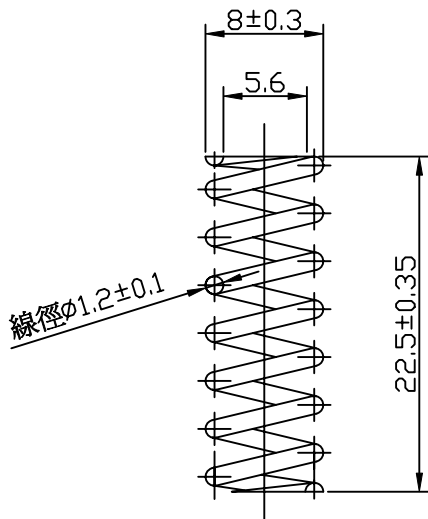
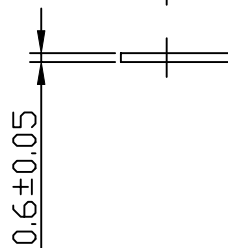
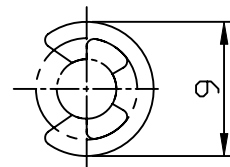
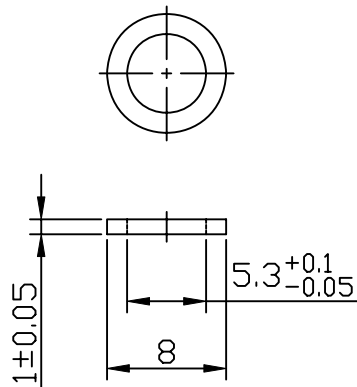
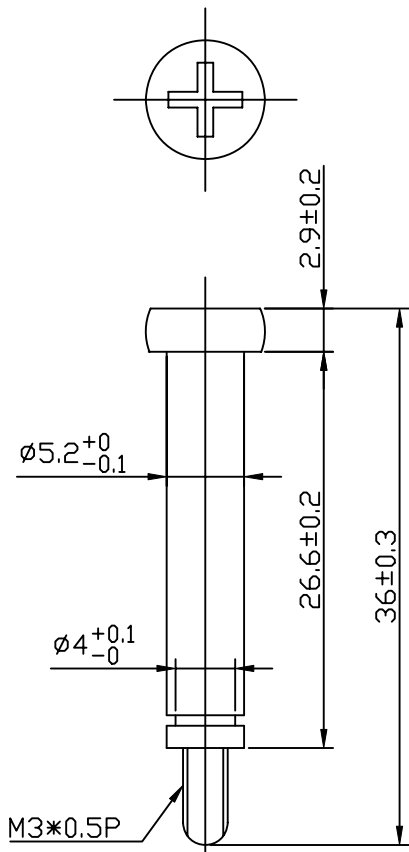

RANGE	TOL ±							URS
	M1	M2	S1	S2	P1	P2	C	
0~6	0.05	0.10	0.15	0.20	0.05	0.10	0.50	0.20
6~30	0.10	0.20	0.15	0.25	0.10	0.15	1.00	0.25
30~120	0.15	0.25	0.20	0.30	0.20	0.40	2.00	0.45
120~300	0.15	0.30	0.25	0.45	0.40	0.80	3.00	0.80
300~600	0.20	0.50	0.40	0.60	0.60	1.20	3.00	1.20
600~1200	0.30	0.80	0.70	1.10	0.80	1.50	4.00	1.50
ANG. TOL±	1°							

MODEL

JAS093C

NAME Spring Screw Kit

--

DRN

Joyce

08/03
2005

MATERIAL

REV.

DESCRIPTION

SIGN

DATE

DSN

Joyce

08/03
2005

FINISH

DIM IN

mm

DO NOT
SCALE DWG

SHEET

1 OF 1

CKD

John

08/03
2005

CHIA CHERNE INDUSTRY CO.,LTD

DRAWING NO.

JAS093C

APPD

Kevin

08/03
2005

A

B

C

D



中國鋼鐵股份有限公司
CHINA STEEL CORPORATION

品質證明書
TEST CERTIFICATE

中華民國高雄市小港區中鋼路1號
LIN HAI INDUSTRIAL DISTRICT P.O. BOX 4
HSIAO KANG KAOHSIUNG(812),
TAIWAN REPUBLIC OF CHINA
TEL: 71108, 71283, 71415 KAOHSIUNG
TEL: (07)802-1111 FAX: (07)803-0927
80170-02

客戶名稱
SOLD TO
榮南工廠股份有限公司
CHUN YU WORKS & CO., LTD.
1, CHIA HSIN RD., CHIA HSIN LI, KANG SHAN CHENG, KAO. HSIEH

規格
SPECIFICATION
AISI 1018, AL-KILLED (BCW02)

檢驗
INSPECTION
CSC MILL INSPECTION

T/C 02

產品名稱
PRODUCT
ROD-CARBON STEEL

標號
MARKING NO.
870225B

客戶編號
CUSTOMER NO.
88187108

交運日期
SHIPMENT DATE

標明書日期
CERTIFICATE DATE

客戶訂單編號
CUSTOMER ORDER NO.
D01206

項目 ITEM NO.	產品序號 SEQ. NO.	尺寸 MATERIAL 直徑/厚 DIAMETER MM	規格 DESCRIPTION 長度 LENGTH MM	重量 WEIGHT KGS	爐號 HEAT NO.	拉伸試驗 TENSILE TEST Y.S. T.S. EL.	化學成份 CHEMICAL ANALYSIS % C Mn P S SI CU NI CR NB AL	備註 REMARKS
SPECIFICATION								
TOTAL:		7.00	COIL 12	17.713	883			
CSC D0851 01								



驗訖

NOTE: (1) CHEMICAL ANALYSIS IS CARRIED OUT BY CSC IN ACCORDANCE WITH TEST METHOD ASTM E415 AND E1019 WHICH CONFORM TO METAL STANDARDS AND SPECIFICATIONS.
(2) TEST SAMPLES ARE LISTED TYPE (3) TEST REPORT RELATES ONLY TO THE SAMPLES BEING TESTED AND THAT SMALL NOT BE VALIDLY RESPONSIBLE.

註明本表所列產品，均係根據規格製造及檢驗，茲符合規格之要求。
AND TESTED WITH SATISFACTORY RESULTS IN ACCORDANCE WITH THE REQUIREMENT OF THE ABOVE MATERIAL SPECIFICATION.

WE HEREBY CERTIFY THAT MATERIAL DESCRIBED HEREIN HAS BEEN MANUFACTURED AND TESTED WITH SATISFACTORY RESULTS IN ACCORDANCE WITH THE REQUIREMENT OF THE ABOVE MATERIAL SPECIFICATION.

SUPERVISOR TO

Yong Shao Chang

QUALITY CERTIFICATION

品質證明書

Customer 客戶	盈豪	Order NO.		Date 日期	2003/3/28
Specification 規格	SW-C 1.20mm	Process No. 製造工令	M30314	Q.A. Department 品質部	
Standard 依據標準	JIS G 3521				
Characteristic 項目	Diameter (mm) 線徑	Ovality (mm) 徑偏差	T.S. (kg/mm ²) 抗拉強度	Twist No.(turns) 扭轉數	Wrapping 捲繞測試
Standard Values 標準值	1.20(-0.015)	0.005MAX	195~220	30MIN	GOOD
Average results 測試平均值	1.193	0.003	203	45	N.A
Chemical Analysis 成份分析	C	Si	Mn	P	S
Standard Values 標準值	0.79~0.86	0.15~0.35	0.30~0.60	0.03MAX	0.03MAX
Test Results 測試平均值	0.83	0.22	0.49	0.018	0.008

PS : Wrapping test is suitable for the wire diameter less than 0.5mm.
註：捲繞測試適用線徑小於0.5mm硬抽鋼線。



Spring Yi Industrial Co., LTD

Spring Yi Industrial Co., Ltd.
品質部

Test Report

CHUNG YIN SPRING INDUSTRIAL CO., LTD.
36, ALLEY 42, CHUNG HSIN N. ST., SAN CHUNG
CITY, TAIPEI HSIEN, TAIWAN, R. O. C.

Report No. : CE/2004/73547
Date : 2004/08/03
Page : 1 of 1

The following merchandise was (were) submitted and identified by the client as :

Type of Product : SAE1018-Ni
Sample Received : 2004/07/27
Testing Date : 2004/07/27 TO 2004/08/03

Test Result

PART NAME NO.1 : SILVER COLORED METAL

Test Item (s):	Unit	Method	MDL	Result			
				No.1			
Chromium VI (Cr+6)	ppm	As per US EPA 7196A and US EPA 3060A.	2	N.D.			
Cadmium (Cd)	ppm	ICP-AES after as per EN 1122, method B:2001 or other acid digestion.	2	N.D.			
Mercury (Hg)	ppm	ICP-AES after as per US EPA 3052 or other acid digestion.	2	N.D.			
Lead (Pb)	ppm	ICP-AES after as per US EPA 3050B or other acid digestion.	2	27.3			

NOTE: (1) N.D., = Not detected (<MDL)
(2) ppm = mg/kg
(3) MDL = Method Detection Limit

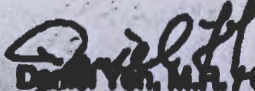
Daniel Yen, M.P., Operation Manager
Signed for and on behalf of
SGS TAIWAN LTD.

This Test Report is issued by the Company subject to its General Conditions of Service printed overleaf. Attention is drawn to the limitations of liability, indemnification, and jurisdictional issues defined therein. The results shown in this test report refer only to the sample(s) tested unless otherwise stated. This Test Report cannot be reproduced, except in full, without prior written permission of the Company. 此報告係根據本公司訂定之檢驗服務條款所製作發給。請注意此報告列印於背圖。與本公司之業務、免費、皆無實質關聯。此報告結果除另有說明關於檢驗之樣品負責。本報告未經本公司書面許可，不可部份複製。

TW 0975158

SGS Taiwan Ltd. | No. 136-1 Wu Kung Road, Wuku Industrial Zone, Taipei County, Taiwan. / 台北縣五股工業區五工路136-1號
台灣檢驗科技股份有限公司 | t (886-2) 2299-3939 | f (886-2) 2299-3237 | www.tw.sgs.com

Member of SGS Group

Test Report

CHUNG YIN SPRING INDUSTRIAL CO., LTD.
36, ALLEY 42, CHUNG HSIN N. ST., SAN CHUNG
CITY, TAIPEI HSIEN, TAIWAN, R. O. C.

Report No. : CE/2004/73545
Date : 2004/08/03
Page : 1 of 1

The following merchandise was (were) submitted and identified by the client as :

Type of Product : SWC-Ni
Sample Received : 2004/07/27
Testing Date : 2004/07/27 TO 2004/08/03

Test Result

PART NAME NO.1 : SILVER COLORED METAL SCREW

Test Item (s):	Unit	Method	MDL	Result			
				No.1			
Chromium VI (Cr+6)	ppm	As per US EPA 7196A and US EPA 3060A.	2	N.D.			
Cadmium (Cd)	ppm	ICP-AES after as per EN 1122, method B:2001 or other acid digestion.	2	N.D.			
Mercury (Hg)	ppm	ICP-AES after as per US EPA 3052 or other acid digestion.	2	N.D.			
Lead (Pb)	ppm	ICP-AES after as per US EPA 3050B or other acid digestion.	2	40.3			

NOTE: (1) N.D. = Not detected (<MDL)
(2) ppm = mg/kg
(3) MDL = Method Detection Limit

Daniel Yen
Daniel Yen, M.P., Operation Manager
Signed for and on behalf of
SGS TAIWAN LTD.

This Test Report is issued by the Company subject to its General Conditions of Service printed overleaf. Attention is drawn to the limitations of liability, indemnification, and Jurisdictional issues defined therein. The results shown in this test report refer only to the sample(s) tested unless otherwise stated. This Test Report cannot be reproduced, except in full, without prior written permission of the Company. 此報告僅屬本公司訂定之通用服務條款所製作之報告。請注意此報告列印於背面。本公司之義務、免責、管轄權聲明等事項。此報告結果除另有說明外均對檢驗之樣品負責。本報告未經本公司同意許可，不可部份複製。

TW 0975156

SGS Taiwan Ltd. | No. 136-1 Wu Kung Road, Wuksu Industrial Zone, Taipei County, Taiwan. / 台北縣五股工業區五工路136-1號
台灣檢驗科技股份有限公司 | (886-2) 2289-3939 | (886-2) 2289-3237 | www.tw.sgs.com

Member of SGS Group



Test Report

CHUNG YIN SPRING INDUSTRIAL CO., LTD.
36, ALLEY 42, CHUNG HSIN N. ST., SAN CHUNG CITY,
TAIPEI HSIEN, TAIWAN, R. O. C.

Report No. : CE/2005/90302
Date : 2005/09/07
Page : 1 of 1

The following merchandise was (were) submitted and identified by the client as :

Type of Product : S50C Ni
Sample Received : 2005/08/31
Testing Date : 2005/08/31 TO 2005/09/07

Test Result

PART NAME NO.1 : SILVER COLORED METAL

Test Item (s):	Unit	Method	MDL	Result
				No. 1
Chromium VI (Cr+6)	ppm	UV-VIS after reference to US EPA 3060A.	2	N.D.
Cadmium (Cd)	ppm	ICP-AES after reference to EN 1122, method B:2001 or other acid digestion.	2	N.D.
Mercury (Hg)	ppm	ICP-AES after reference to US EPA 3052 or other acid digestion.	2	N.D.
Lead (Pb)	ppm	ICP-AES after reference to US EPA 3050B or other acid digestion.	2	N.D.

NOTE: (1) N.D. = Not detected (<MDL)
(2) ppm = mg/kg
(3) MDL = Method Detection Limit

Daniel Yen, M.R. / Operation Manager
Signed for and on behalf of
SGS TAIWAN LTD.

The content of this PDF file is in accordance with the original issued reports for reference only. This Test Report cannot be reproduced, except in full, without prior written permission of the Company

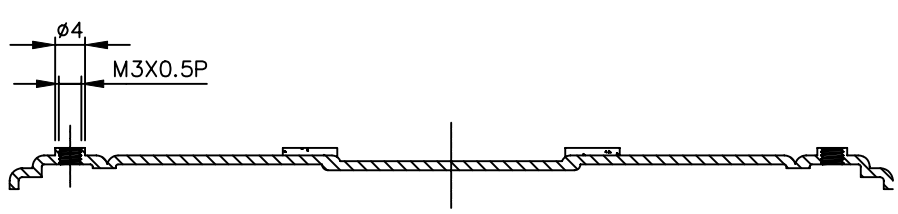
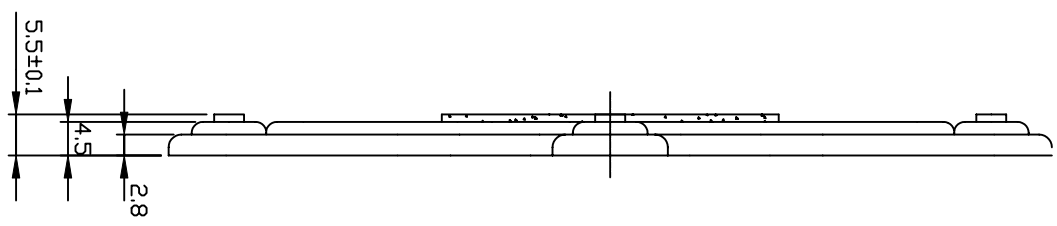
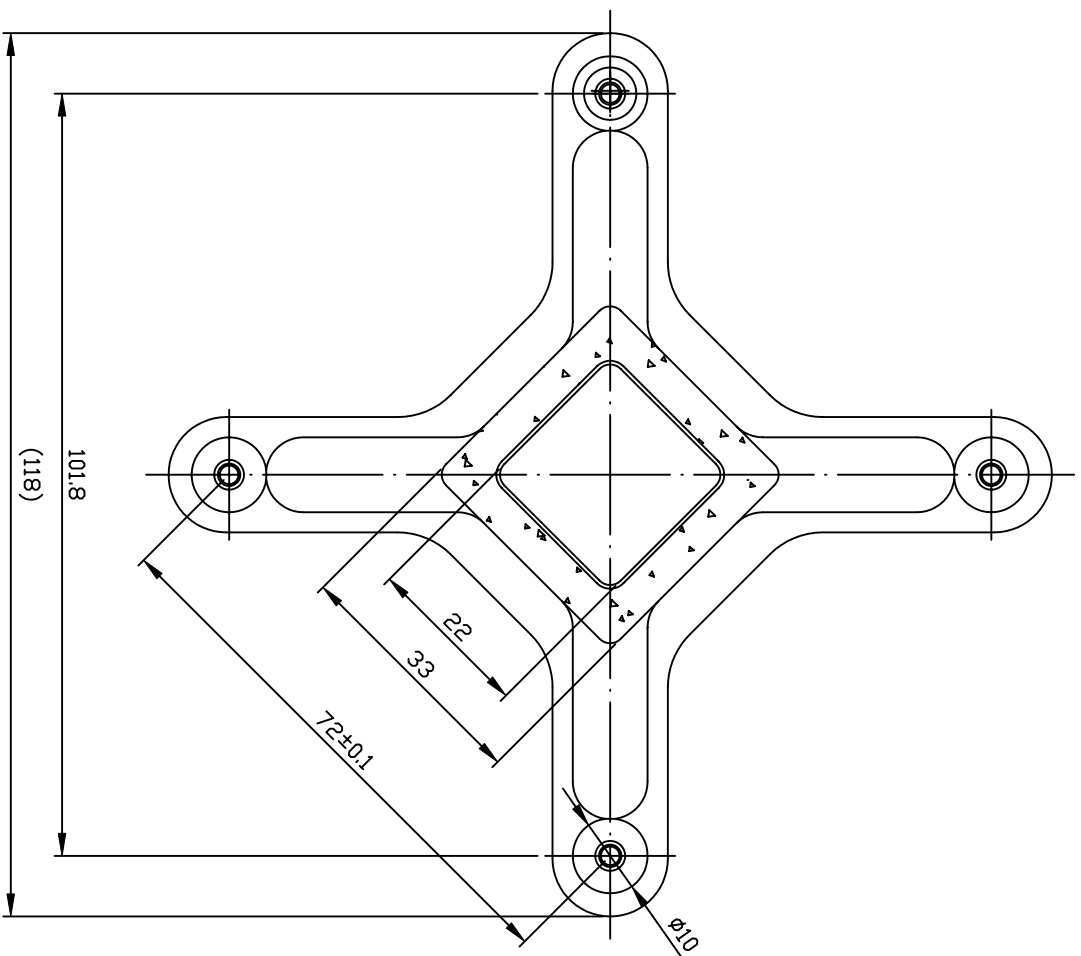

RANGE	TOL #										URS
	M1	M2	S1	S2	P1	P2	C				
0~6	0.05	0.10	0.15	0.20	0.05	0.10	0.50				0.20
6~30	0.10	0.20	0.15	0.25	0.10	0.15	1.00				0.25
30~120	0.15	0.25	0.20	0.30	0.20	0.40	2.00				0.45
120~300	0.15	0.30	0.25	0.45	0.40	0.80	3.00				0.80
300~600	0.20	0.50	0.40	0.60	0.60	1.20	3.00				1.20
600~1200	0.30	0.80	0.70	1.10	0.80	1.50	4.00				1.50

MODEL	NAME
JAT055	Base Plate
DRN: Kathy	DRN: Kathy
DSN: David	DSN: David
CKD: John	CKD: John
APPD: Jerry	APPD: Jerry
MATERIAL	FINISH
---	---
CHIA CHERNE INDUSTRY CO.,LTD	

REV.	DESCRIPTION	SIGN	DATE

DIM IN	mm	DD NOT SCALE DWG
SHEET	1	DF
JAT055		

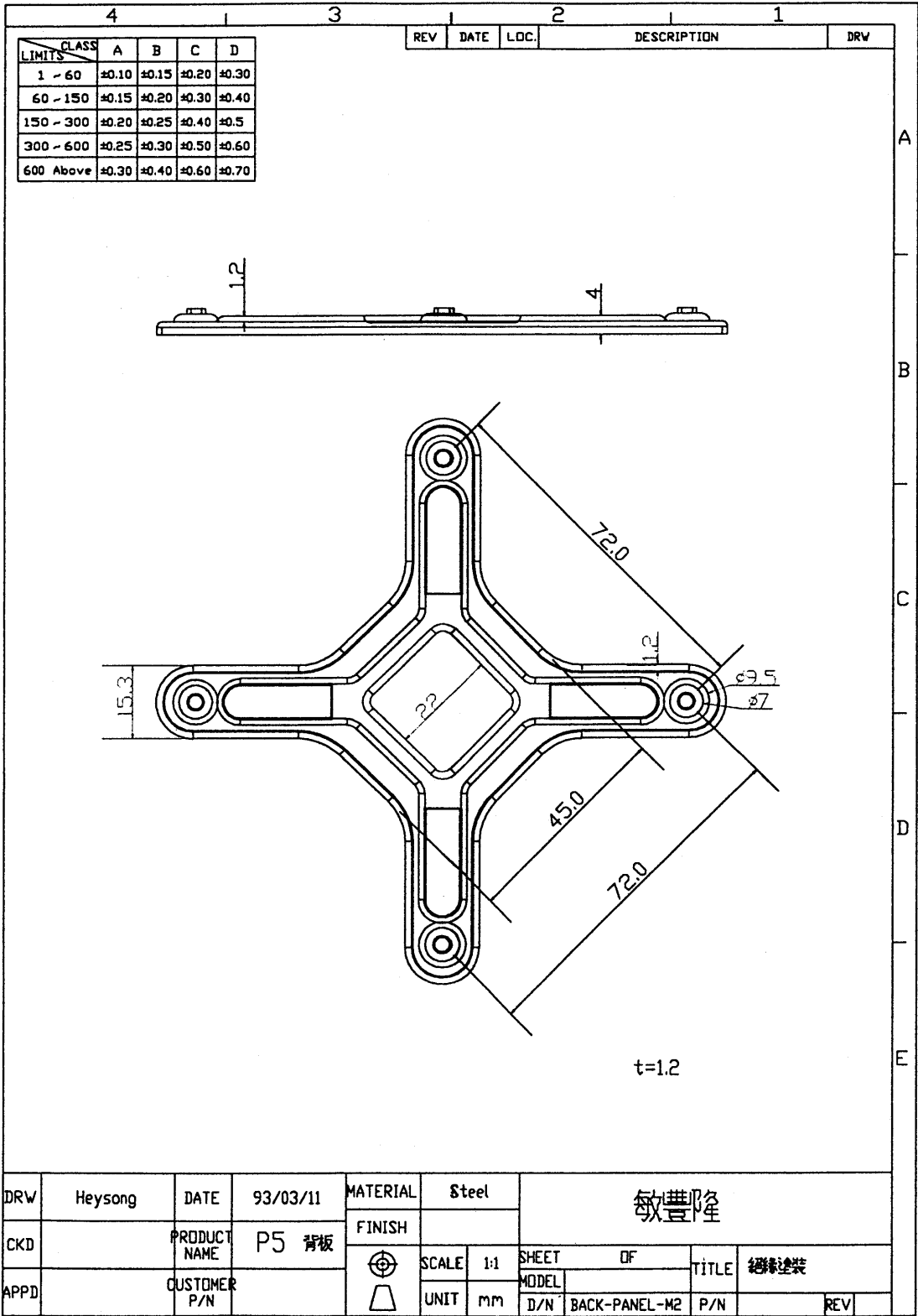

DRW	Heysong	DATE	93/03/11	MATERIAL	Steel	敏普隆					
CKD		PRODUCT NAME	P5 背板	FINISH		SHEET		OF	TITLE		總裝
APPD		CUSTOMER P/N		⊕	SCALE	1:1	MODEL		D/N		BACK-PANEL-M2
				△	UNIT	mm	P/N		REV		

產 品 簡 介

品名：EVA塑膠海棉板 (Ethylone Vinyl Acetate Sponge Sheet)
加工方法：壓縮成型 (發泡)

特性及用途：

EVA發泡是一種共聚合塑膠，具有很多優異特性，包括柔軟而有彈性、透明、無毒、抗外界應力龜裂性很強、抗衝擊强度高、低溫柔軟性很好，以及加工容易，所以用以發展新用途及代替PE、橡膠及其他彈性材料。

本公司新用途之一，是添加潤滑劑、交聯劑及發泡劑，以壓縮成型製造，等高品质EVA塑膠海棉板，目前盛行使用於工業界精密儀器、耐衝擊吸收材、電氣絕緣板、防震材、迫緊、背膠、包裝用包裝材、運動器具、鞋類、帽子、運動袋、玩具、遊樂用品、教育資料等。

成品性質：

特性	品名	EVA 塑 膠 海 棉 板		
硬度 HARDNESS	25	30	50	
密度 DENSITY \times / CM^3	0.10-0.20	0.20-0.25	0.3-0.35	
抗張強度 TENSILE STRENGTH	8 Kg/cm^2	7	9	
延伸率 ELONGATION %	450	500	500	
發泡率 BLOWING	14倍	10倍	10倍	
防水率 WATER ABSORPTION	0.3% 以下			

製 成 品 所 需 用 料 數 量 表

應 用 原 料 名 稱 及 數 量		
中 文 名 稱	英 文 名 稱	應 用 數 量
E.V.A. 塑 膠 粒	Ethylene Vinyl Acetate Resin	60.00%
發 泡 劑	Blowing Agent	2.5 %
觸 媒 劑	Cross Linking Agent "Percunyl D"	0.63%
白 陶 土	Hakuanka CC	14.00%
美 國 硬 土	Clay	15.50%
硬 脂 酸	Stearic Acid	1.50%
人 造 膠	Ethylene Propylene Kubbar	5.82%
Total		100 %

APPLICANT: TONG YU INDUSTRY CO., LTD
NO2-32 LANE 518
SEC 3 CHUNGSHAN RD
CHANGHUA CITY CHANGHUA COUNTY 500
TAIWAN R.O.C.

DATE : JAN 06, 2006

SAMPLE DESCRIPTION:

ONE (1) GROUP OF SUBMITTED SAMPLES SAID TO BE :
SAMPLE DESCRIPTION : JIS G3141 SERIES + ANODIZING BLACK
DATE SAMPLE RECEIVED : DEC 30, 2005
DATE TEST STARTED : DEC 30, 2005

TESTS CONDUCTED:

AS REQUESTED BY THE APPLICANT, FOR DETAILS PLEASE REFER TO ATTACHED PAGES.

PREPARED AND CHECKED BY:
FOR INTERTEK TESTING SERVICES
TAIWAN LIMITED



JACOB LIN
GENERAL MANAGER

TESTS CONDUCTED

(A) TEST RESULT SUMMARY :

TESTING ITEM	RESULT (ppm)
	SUBMITTED SAMPLES
CADMIUM (Cd) CONTENT	ND
LEAD (Pb) CONTENT	26
MERCURY (Hg) CONTENT	ND
CHROMIUM VI (Cr ⁶⁺) CONTENT	ND

REMARKS : ppm = PARTS PER MILLION
 ND = NOT DETECTED

(B) TEST METHOD :

TESTING ITEM	TESTING METHOD	REPORTING LIMIT
CADMIUM (Cd) CONTENT	WITH REFERENCE TO USEPA 3052, BY MICROWAVE DIGESTION AND DETERMINED BY ICP-OES	2 ppm
LEAD (Pb) CONTENT	WITH REFERENCE TO USEPA 3052, BY MICROWAVE DIGESTION AND DETERMINED BY ICP-OES	2 ppm
MERCURY (Hg) CONTENT	WITH REFERENCE TO USEPA 3052, BY MICROWAVE DIGESTION AND DETERMINED BY ICP-OES	2 ppm
CHROMIUM VI (Cr ⁶⁺) CONTENT	WITH REFERENCE TO USEPA 3060A & 7196A, BY ALKALINE DIGESTION AND DETERMINED BY UV-VIS	1 ppm

REMARK : REPORTING LIMIT = QUANTITATION LIMIT OF ANALYTE IN SAMPLE

 END OF REPORT

IAT055 A/A

規 格 表

SPECIFICATION

品名 Part No.: DSS

DATE: 2002/05/16

項 目 ITEM	單 位 UNIT	規 格 值 SPEC. VALUES	檢 驗 方 法 TEST METHOD
I. 規格及容許差 Dimension & tolerance			
1. 厚度 Thickness:	mm	0.10 ± 0.02	
2. 紙卷內徑 Inside Diameter of roll:	mm	77 +	
3. 重量 Weight:	g/m ²	1	
II. 組成 Composition:			
1. 原紙 Backing:		TISSUE PAPER	
基重 Base Weight:	g/m ²	15	
厚度 Thickness:	mm	ACRYLIC BASE	
2. 粘膠 Glue:			
III. 物性與化性 Physical & Chemical Properties:			
1. 180° 剝離粘着力 180° Peel Adhesion			
對鋼板 To Steel:	kg/25mm	0.55	ASTM D-1000
對背面 To Backing:	kg/25mm	↑	
2. 保持力 Holding Power:	min	700	PSTC-7
3. 剝離力 Unwind Force	g/25mm	↑	
4. 張力強度 Tensile Strength:	kg/25mm	1.5	ASTM D-1000
5. 伸長率 Elongation:	%	↑	ASTM D-1000
6. 耐熱性 Heat Resistance:	°C		
7. 耐溶劑性 Solvent Resistance:	min		
8. 耐寒性 Cold Resistance:			
9. 耐候性 Weatherability:			
10. 耐燃性 Flammability:	sec		UL 510
11. 變形 Deformation:			
12. 破壞電壓 Dielectric Breakdown:	KV		ASTM D-1000
13. 初期力 Tack:	14#/cm		
14. 纖維面積 Fiber Tear:	%		
15. 引拔力 Dynamic Shear Testing:	kg/10mm		
16. 分層剝離力 Delaminated Force:	kg/25mm		
17. 撕裂強度 Elmendorf Test Tearing Strength:	g/16mm		
18. 自著力 Self Adhesive Force:	kg/25mm		
19. 遮蔽率 Hiding Power:	張		
20. 密度 Density	g/cm ³		
21. 體積抵抗率 Volume Resistivity	Ω-cm		
22. 儲存條件 Storage Condition:		73°F, 60% R.H	
23. 儲存有效期間 Storage Validity:	year	1	
24.			
25.			

產 品 簡 介

品名：EVA塑膠海棉板 (Ethylene Vinyl Acetate Sponge Sheet)

加工方法：壓縮成型 (發泡)

特性及用途：

EVA發泡是一種共聚合塑膠，具有很多優異特性，包括柔軟而有彈性、透明、無毒、抗外界應力龜裂性很強、抗衝擊强度高、低溫柔軟性很好，以及加工容易，所以用以發展新用途及代替PE、橡膠及其他彈性材料。

本公司新用途之一，是添加潤滑劑、交聯劑及發泡劑，以壓縮成型製造，等高品質EVA塑膠海棉板，目前盛行使用於工業界精密儀器、耐衝擊吸收材、電氣絕緣板、防震材、迫緊、背膠、包裝用包裝材、運動器具、鞋類、帽子、運動袋、玩具、遊樂用品、教育資料等。

成品性質：

品名	EVA 塑 膠 海 棉 板		
特性			
硬度 HARDNESS	25	30	50
密度 DENSITY g/cm^3	0.10-0.20	0.20-0.25	0.3-0.35
抗張強度 TENSILE STRENGTH	8 Kg/cm^2	7	9
延伸率 ELONGATION %	450	500	500
發泡率 BLOWING	14倍	10倍	10倍
防水率 WATER ABSORPTION	0.3% 以下		

製 成 品 所 需 用 料 數 量 表

應 用 原 料 名 稱 及 數 量		
中 文 名 稱	英 文 名 稱	應 用 數 量
E.V.A. 塑 膠 粒	Ethylene Vinyl Acetate Resin	80.00%
發 泡 劑	Blowing Agent	2.5 %
觸 媒 劑	Cross Linking Agent "Percumyl D"	0.03%
白 陶 土	Hakuenka CC	14.00%
美 國 硬 土	Clay	15.50%
硬 脂 酸	Stearic Acid	1.50%
人 造 膠	Ethylene Propylene Rubber	5.82%
Total		100 %

Test Report

敏豐隆企業有限公司

報告號碼 : CE/2005/81102B

日期 : 2005/08/11

頁數 : 1 of 4

以下測試樣品乃供應廠商所提供及確認：

樣品名稱 : EVA
產品型號 : EVA
收件日期 : 2005/07/14 & 2005/08/04
測試日期 : 2004/07/14 TO 2004/07/21 &
2005/08/04 TO 2005/08/11

測試結果 : 此份樣品所化驗的化學物質—鉛、鎘、汞、六價鉻、多溴聯苯及多溴聯苯醚的測試結果，符合RoHS指令

* 此份報告為合併CE/2004/72761A之報告 *

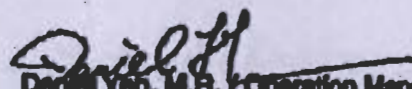
Daniel Yen, M.R. / Operation Manager
Signed for and on behalf of
SGS TAIWAN LTD.

The content of this PDF file is in accordance with the original issued reports for reference only. This Test Report cannot be reproduced, except in full, without prior written permission of the Company

Test Report

敏豐隆企業有限公司

報告號碼 : CE/2005/81102B

日期 : 2005/08/11

頁數 : 2 of 4

測試結果

測試部位 NO.1 : 黑色EVA(請參照附件圖片)

通過

測試項目:	單位	測試方法	偵測極限值	結果	ROHS
				NO.1	限值
一溴聯苯	%	本測試參考USEPA3540C 或 USEPA3550C方法, 以氣相層析儀/質譜儀(GC/MS)或高效液相層析儀/二極體陣列偵測器/質譜儀(HPLC/DAD/MS)檢測之(參考歐盟規範 2002/95/EC (RoHS), 83/264/EEC, 76/769/EEC)	0.0005	N.D.	-
二溴聯苯	%		0.0005	N.D.	-
三溴聯苯	%		0.0005	N.D.	-
四溴聯苯	%		0.0005	N.D.	-
五溴聯苯	%		0.0005	N.D.	-
六溴聯苯	%		0.0005	N.D.	-
七溴聯苯	%		0.0005	N.D.	-
八溴聯苯	%		0.0005	N.D.	-
九溴聯苯	%		0.0005	N.D.	-
十溴聯苯	%		0.0005	N.D.	-
多溴聯苯(PBBs)/以上總和	%		-	N.D.	0.1
一溴聯苯醚	%	本測試參考USEPA3540C 或 USEPA3550C方法, 以氣相層析儀/質譜儀(GC/MS)或高效液相層析儀/二極體陣列偵測器/質譜儀(HPLC/DAD/MS)檢測之(參考歐盟規範 2002/95/EC (RoHS), 83/264/EEC, 76/769/EEC)	0.0005	N.D.	-
二溴聯苯醚	%		0.0005	N.D.	-
三溴聯苯醚	%		0.0005	N.D.	-
四溴聯苯醚	%		0.0005	N.D.	-
五溴聯苯醚	%		0.0005	N.D.	-
六溴聯苯醚	%		0.0005	N.D.	-
七溴聯苯醚	%		0.0005	N.D.	-
八溴聯苯醚	%		0.0005	N.D.	-
九溴聯苯醚	%		0.0005	N.D.	-
十溴聯苯醚	%		0.0005	N.D.	-
多溴聯苯醚(PBBs/PBDEs)/以上總和	%		-	N.D.	0.1

The content of this PDF file is in accordance with the original issued reports for reference only. This Test Report cannot be reproduced, except in full, without prior written permission of the Company

Test Report

敏豐隆企業有限公司

報告號碼 : CE/2005/81102B

日期 : 2005/08/11

頁數 : 3 of 4

通過

測試項目	單位	測試方法	偵測極限值	結果	ROHS 限值
				NO.1	
六價鉻	ppm	依照US EPA 3060A方法, 用UV-VIS 做分析	2	N.D.	1000
鎘	ppm	依照 EN1122 方法B:2001或其他酸 消化方法,用感應耦合電漿原子發 射光譜儀(ICP-AES)做分析	2	N.D.	100
汞	ppm	依照 US EPA 3052 方法或其他酸 消化方法,用感應耦合電漿原子發 射光譜儀(ICP-AES)做分析	2	N.D.	1000
鉛	ppm	依照 US EPA 3050B 方法或其他酸 消化方法,用感應耦合電漿原子發 射光譜儀(ICP-AES)做分析	2	N.D.	1000

備註:(1) N.D. = Not detected.(<MDL) / 未檢出(低於偵測極限值)

(2) ppm = mg/kg / 百萬分之一

(3) MDL= Method Detection Limit(偵測極限值)

(4) " - " = Not Regulation / 無規格值

Test Report

敏豐隆企業有限公司

報告號碼 : CE/2005/81102B

日期 : 2005/08/11

頁數 : 4 of 4



The content of this PDF file is in accordance with the original issued reports for reference only. This Test Report cannot be reproduced, except in full, without prior written permission of the Company

SC102

HEAT-TRANSFER COMPOUND

SC102 heat-transfer compound is a grease like silicone material heavily filled with heat-conductive metal oxide.

SC102 heat-transfer compound is an improved product that can be used in touch with silicone JCR, where most of silicone heat-transfer compounds cause swelling of JCR. SC102 also shows excellent heat conductivity as well very little oil bleed. SC102 has rather high consistency and it is easy to handle and can be used in many appliances.

Properties of SC102

Properties	Unit	SC102
Consistency, penetration un-worked	--	300
Oil bleed (120°C / 24hrs)	%	0.00
Specific Gravity	--	2.45
Thermal Conductivity	Cal / cm • sec. C	0.0019
Arc Resistance	sec.	123
Dielectric Constant	60 Hz	4.6
	1000 Hz	4.4
Dissipation Factor	60 HZ	0.034
	1000 HZ	0.024
Volume Resistivity	ohm • cm	4.8×10^{14}
Dielectric Strength	kV / 2.5mm	22

Properties of SC102 in comparison with SH340

Properties	SC102	SH340 ^{a)}
Swelling of Silicone JCR ^{b)} Volume increase	0.9%	3.0%
Oil bleed on aluminum plate 120°C / 24hrs	None	observed
Appearance after heating 150°C / 24hrs	No change	No change

a) Conventional silicone heat-transfer compound

b) Cured silicone JCR (SH6101) was immersed in heat-transfer compound at 120°C for 120hrs.

Dow Corning Toray Silicone Co., Ltd.

AIG Bldg. 1-3, Marunouchi 1-chome, chiyoda-ku

Tokyo 100-0005, Japan

TEL: 03-3287 8300

IMPORTANT NOTICE :Dow Corning Toray Silicone neither represents nor tests this material for medical device applications or for pharmaceutical end-use.
NOT FOR HUMAN INJECTION !

This product is made to industrial grade standards. It is not intended for nor should it be used in medical device applications and pharmaceutical end-use.

Test Report

SIL-MORE INDUSTRIAL LTD.
16F, NO. 100, HSIN TEH ROAD, SAN CHUNG CITY,
TAIPEI COUNTY, TAIWAN, R. O. C.

Report No. : CE/2005/81840
Date : 2005/08/15
Page : 1 of 4

The following merchandise was (were) submitted and identified by the client as :

Type of Product : DOW CORNING TORAY SC102 HEAT SINK COMPOUND
Sample Received : 2005/08/09
Testing Date : 2005/08/09 TO 2005/08/15

=====
Test Result : - Please see the next page -

Daniel Yen, M.R. / Operation Manager
Signed for and on behalf of
SGS TAIWAN LTD.

Test Report

SIL-MORE INDUSTRIAL LTD.
16F, NO. 100, HSIN TEH ROAD, SAN CHUNG CITY,
TAIPEI COUNTY, TAIWAN, R. O. C.

Report No. : CE/2005/81840
Date : 2005/08/15
Page : 2 of 4

Test Result

PART NAME NO.1 : WHITE COLLOID (PLEASE REFER TO THE PHOTO ATTACHED)

Test Item (s):	Unit	Method	MDL	Result
				No. 1
Monobromobiphenyl	%	With reference to USEPA3540C or USEPA3550C. Analysis was performed by HPLC/DAD, LC/MS or GC/MS. (prohibited by 2002/95/EC (RoHS), 83/264/EEC, and 76/769/EEC)	0.0005	N.D.
Dibromobiphenyl	%		0.0005	N.D.
Tribromobiphenyl	%		0.0005	N.D.
Tetrabromobiphenyl	%		0.0005	N.D.
Pentabromobiphenyl	%		0.0005	N.D.
Hexabromobiphenyl	%		0.0005	N.D.
Heptabromobiphenyl	%		0.0005	N.D.
Octabromobiphenyl	%		0.0005	N.D.
Nonabromobiphenyl	%		0.0005	N.D.
Decabromobiphenyl	%		0.0005	N.D.
Total PBBs(Polybrominated biphenyls)/Sum of above	%		-	N.D.
Monobromobiphenyl ether	%	With reference to USEPA3540C or USEPA3550C. Analysis was performed by HPLC/DAD, LC/MS or GC/MS. (prohibited by 2002/95/EC (RoHS), 83/264/EEC, and 76/769/EEC)	0.0005	N.D.
Dibromobiphenyl ether	%		0.0005	N.D.
Tribromobiphenyl ether	%		0.0005	N.D.
Tetrabromobiphenyl ether	%		0.0005	N.D.
Pentabromobiphenyl ether	%		0.0005	N.D.
Hexabromobiphenyl ether	%		0.0005	N.D.
Heptabromobiphenyl ether	%		0.0005	N.D.
Octabromobiphenyl ether	%		0.0005	N.D.
Nonabromobiphenyl ether	%		0.0005	N.D.
Decabromobiphenyl ether	%		0.0005	N.D.
Total PBBEs(PBDEs)(Polybrominated biphenyl ethers)/Sum of above	%		-	N.D.

Test Report

SIL-MORE INDUSTRIAL LTD.
16F, NO. 100, HSIN TEH ROAD, SAN CHUNG CITY,
TAIPEI COUNTY, TAIWAN, R. O. C.

Report No. : CE/2005/81840
Date : 2005/08/15
Page : 3 of 4

Test Item (s):	Unit	Method	MDL	Result
				No.1
Chromium VI (Cr+6)	ppm	UV-VIS after reference to US EPA 3060A.	2	N.D.
Cadmium (Cd)	ppm	ICP-AES after reference to EN 1122, method B:2001 or other acid digestion.	2	N.D.
Mercury (Hg)	ppm	ICP-AES after reference to US EPA 3052 or other acid digestion.	2	N.D.
Lead (Pb)	ppm	ICP-AES after reference to US EPA 3050B or other acid digestion.	2	N.D.

NOTE: (1) N.D. = Not detected (<MDL)
(2) ppm = mg/kg
(3) MDL = Method Detection Limit
(4) " - " = No Regulation

Test Report

SIL-MORE INDUSTRIAL LTD.
16F, NO. 100, HSIN TEH ROAD, SAN CHUNG CITY,
TAIPEI COUNTY, TAIWAN, R. O. C.

Report No. : CE/2005/81840
Date : 2005/08/15
Page : 4 of 4

