

REVISIONS				
P	LTN	DESCRIPTION	DATE	OWN APVD
1		INITIAL RELEASED	17OCT13	KD JY
2		REVISED TABS BENDED DIRECTION PER ACTUAL	30MAR2015	TX JY
4		REVISED PER ECN-22-163746	11JUL2022	IT SZ

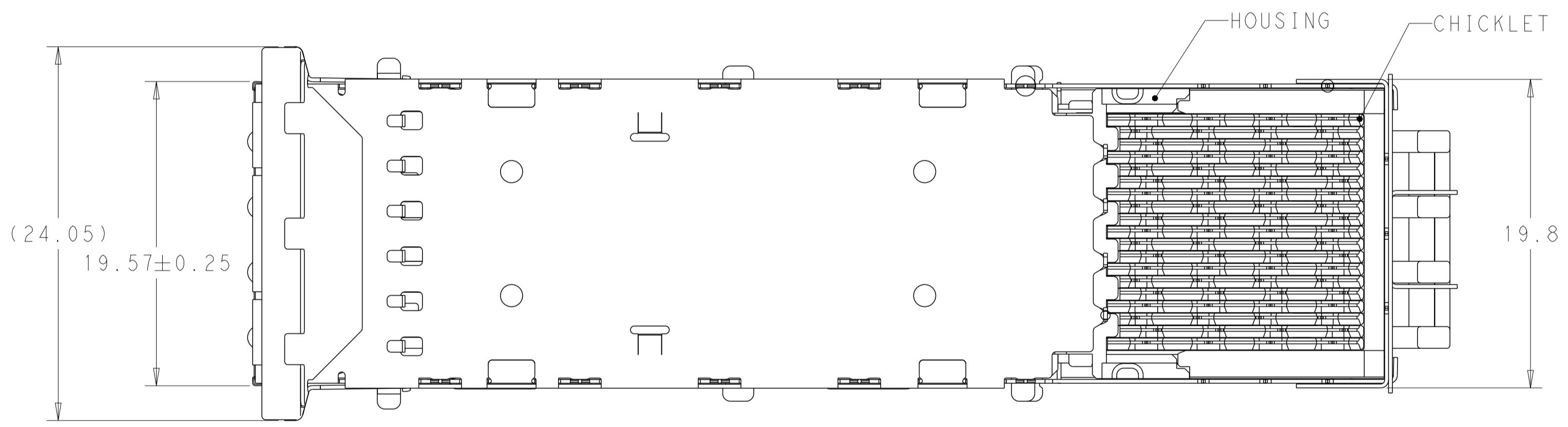
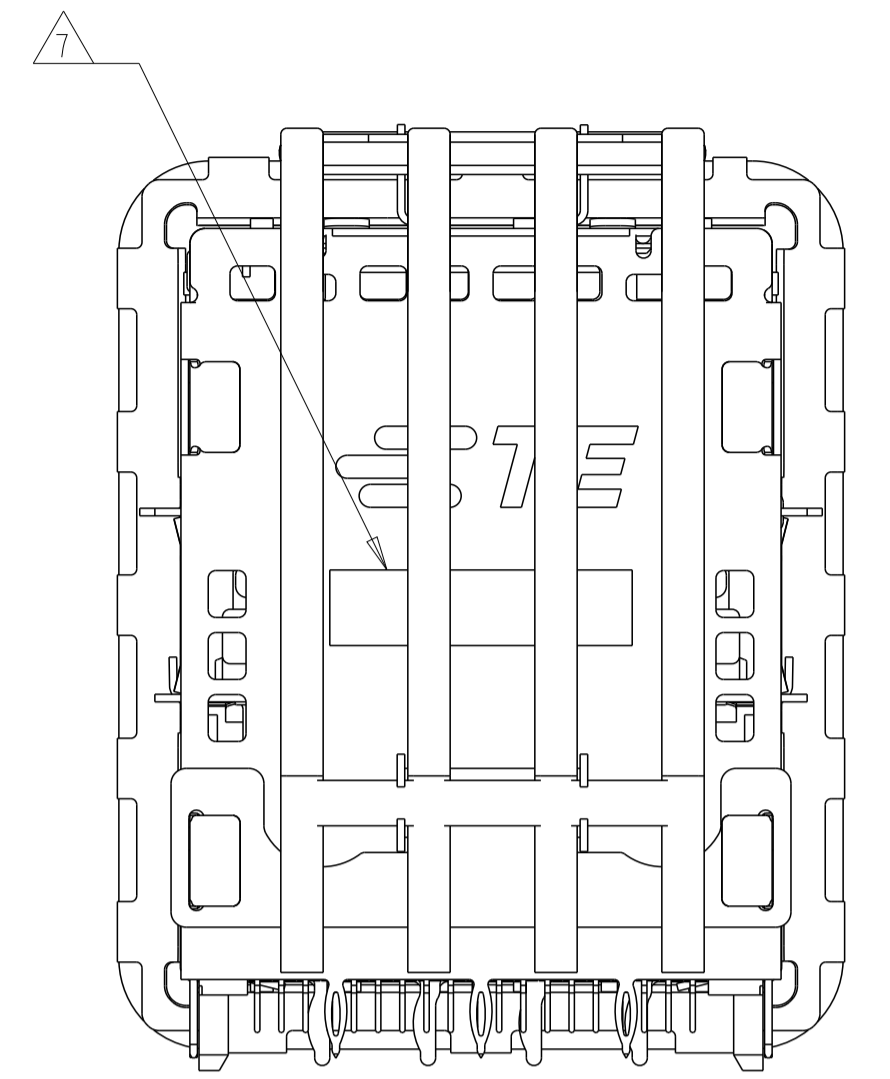
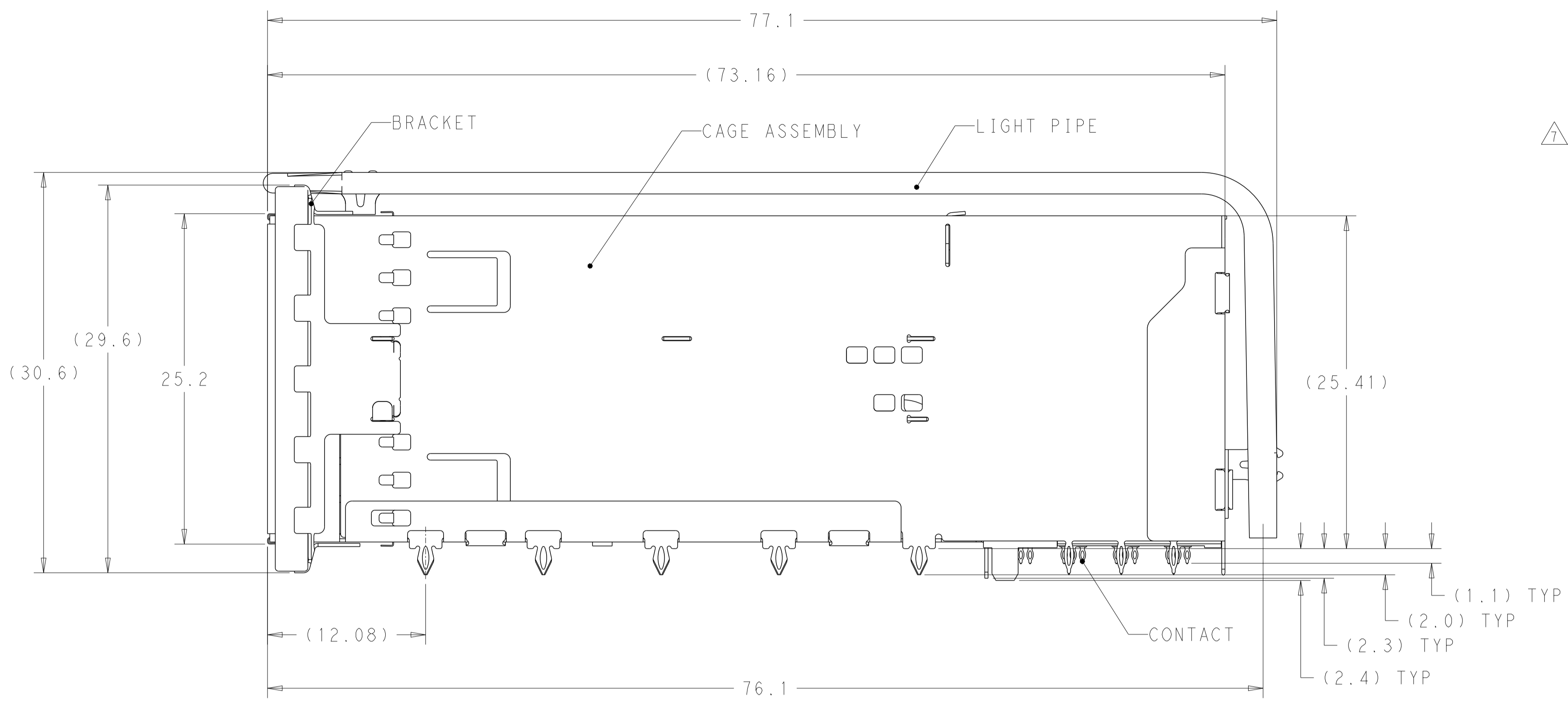
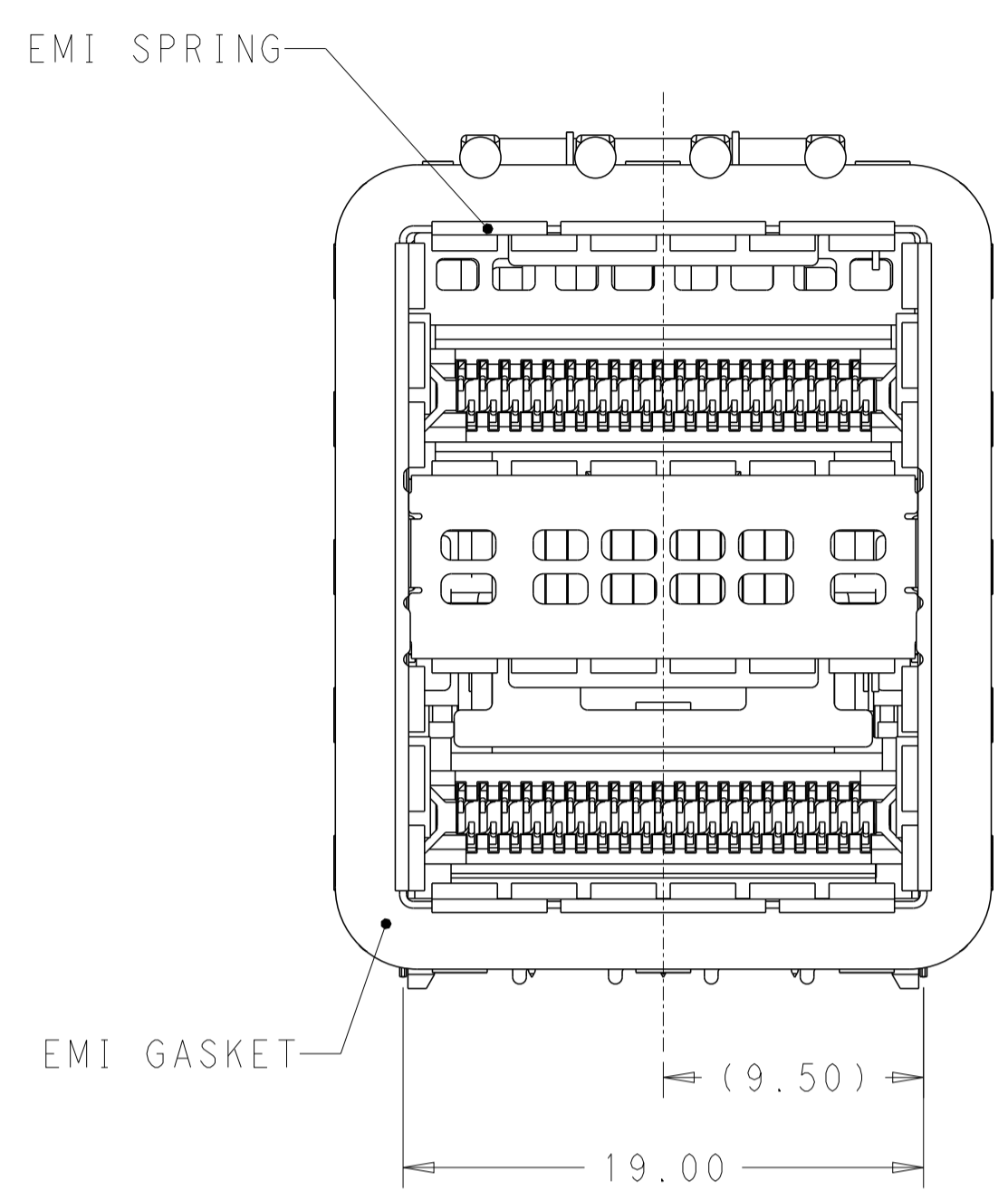

1. MATERIALS:
 CAGE ASSEMBLY- NICKEL SILVER ALLOY PER ASTM B 122.
 BRACKET- STAINLESS STEEL.
 EMI SPRING- COPPER ALLOY, NICKEL PLATED.
 EMI GASKET- PLATED FILLED SILICONE.
 HOUSING- POLYESTER LCP WITH 94V-0.
 CHICKLET- POLYESTER LCP WITH 94V-0.
 CONTACT- COPPER ALLOY.
 LIGHTPIPE- POLYCARBONATE WITH 94V-0.

- 2 CONTACT FINISH: 0.76µm GOLD ON MATING END, 1.25µm MATT TIN ON SOLDER TAIL, ALL OVER 1.27µm NICKEL.
 3 DATUM AND BASIC DIMENSION ESTABLISHED BY CUSTOMER.
 4. MINIMUM PCB THICKNESS: 1.57mm.
 5 THE ENTIRE AREA OF THE CONNECTOR FOOTPRINT, INDICATED BY THE DASHED LINE, TO BE CONSIDERED THE KEEPOUT AREA FOR COMPONENTS.
 6 CROSS-HATCHED AREAS REPRESENT ZONES ON THE PCB THAT COME IN CONTACT WITH OR BE IN CLOSE PROXIMITY TO THE PLASTIC HOUSING OR THE CONNECTOR CAGE. INDICATED AREAS TO BE CONSIDERED TRACE FREE.
 7 PART NUMBER AND DATE CODE MARKED IN APPROXIMATE AREA SHOWN.
 8 HATCHED AREA IS PLACEMENT ZONE FOR LED. LED SHOULD BE CENTERED WITHIN ZONE. RECOMMEND 0805 PACKAGE.
 9 CONTACT FINISH: 0.08µm MINIMUM GOLD OVER 0.68µm PALLADIUM-NICKEL ON MATING END, 1.25µm MATT TIN ON SOLDER TAIL, ALL OVER 1.27µm NICKEL.

PRELIMINARY - NOT RELEASED FOR PRODUCTION

THIS PRODUCT HAS NOT COMPLETED VALIDATION AND QUALIFICATION TESTING

CONTACT FINISHED	DESCRIPTION	PART NUMBER
9	Pd-Ni PLATING	2170608-2
2	Au PLATING	2170608-1

THIS DRAWING IS A CONTROLLED DOCUMENT. DIMENSIONS: mm. TOLERANCES UNLESS OTHERWISE SPECIFIED: 0 PLC ±.25, 1 PLC ±.15, 2 PLC ±.15, 3 PLC ±.013, 4 PLC ±.0001. ANGLES ±2°. MATERIAL: SEE NOTE 1. FINISH: SEE NOTE 2. CUSTOMER DRAWING. SCALE: 4:1. SHEET 1 OF 4. REV 4.

OWN: KEVIN DING 17OCT13
 CHG: JASON YANG 17OCT13
 APVD: JASON YANG 17OCT13
 NAME: JASON YANG
 PRODUCT SPEC: JASON YANG
 APPLICATION SPEC: JASON YANG
 WEIGHT: -
 SIZE: A1
 CAGE CODE: 00779
 DRAWING NO: 2170608
 RESTRICTED TO: -

STE TE Connectivity
 CAGE AND CONNECTOR ASSEMBLY, WITH EMI GASKET, 2X1 THERMAL FOOTPRINT, ZQSFP+STACKED

REVISIONS				
P	LTN	DESCRIPTION	DATE	APVD
-	-	SEE SHEET 1	-	-

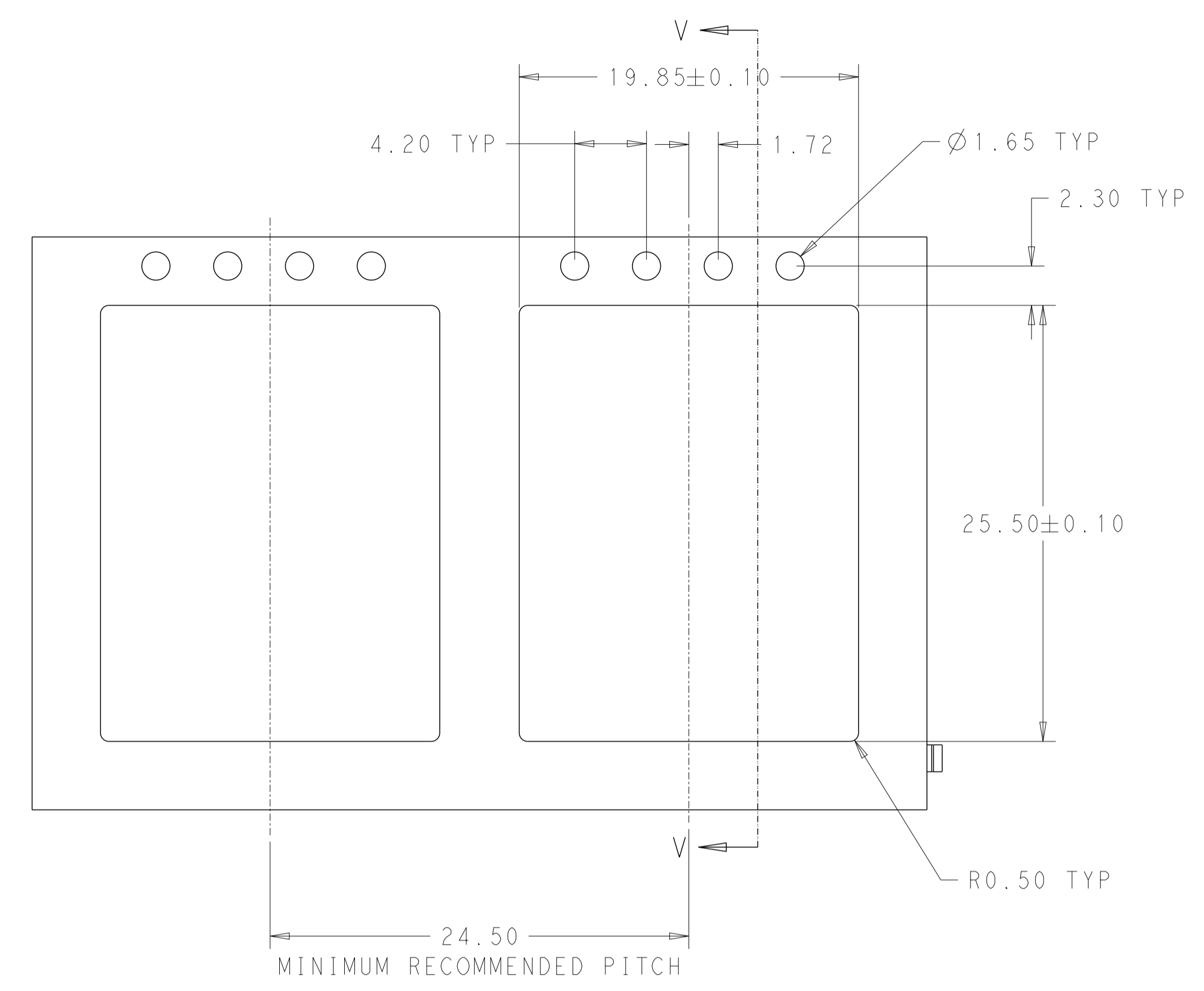

RECOMMEND PANEL CUTOUT
 AND PC BOARD, PANEL POSITION

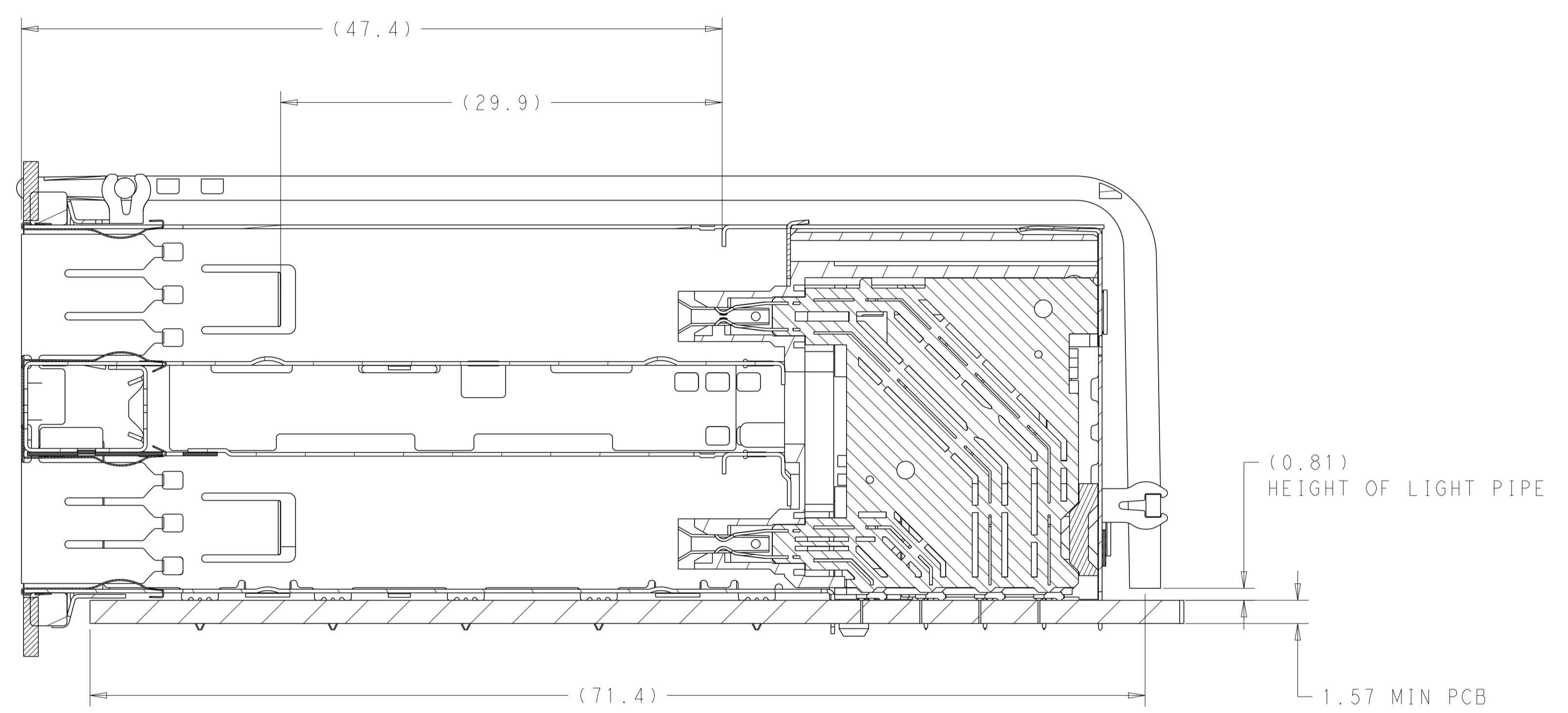

SECTION V-V
 SCALE 4:1

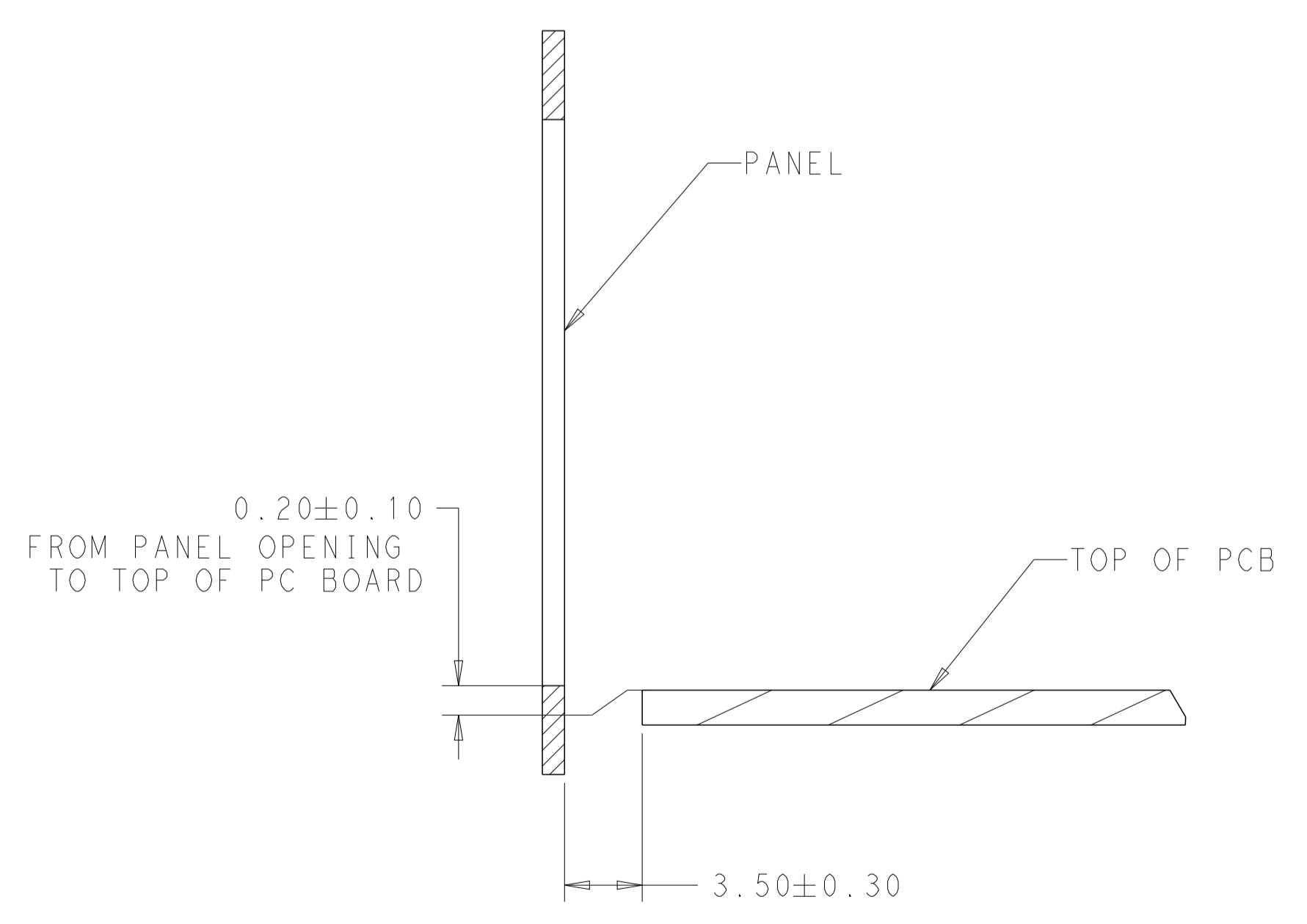

SECTION V-V
 SCALE 4:1

THIS PRODUCT HAS NOT
 COMPLETED VALIDATION AND
 QUALIFICATION TESTING

PRELIMINARY - NOT RELEASED FOR PRODUCTION

THIS DRAWING IS A CONTROLLED DOCUMENT.		DWN: REVIN DING 17OCT13	TE Connectivity
DIMENSIONS:		CHK: JASON YANG 17OCT13	
mm	TOLERANCES UNLESS OTHERWISE SPECIFIED:	APVD: JASON YANG 17OCT13	NAME: CAGE AND CONNECTOR ASSEMBLY, WITH EMI GASKET, 2X1, THERMAL FOOTPRINT, ZQSFP+STACKED
	0 PLC ± 1 PLC ±0.25 2 PLC ±0.15 3 PLC ±0.013 4 PLC ±0.0001 ANGLES ±2°	PRODUCT SPEC	SIZE: CAGE CODE DRAWING NO
MATERIAL: SEE NOTE 1	FINISH: SEE NOTE 2	APPLICATION SPEC	RESTRICTED TO
		WEIGHT: -	A100779C=2170608
		CUSTOMER DRAWING	SCALE 4:1 SHEET 2 OF 4 REV 4

REVISIONS				
P.	LTN.	DESCRIPTION	DATE	APVD.
-	-	SEE SHEET 1	-	-

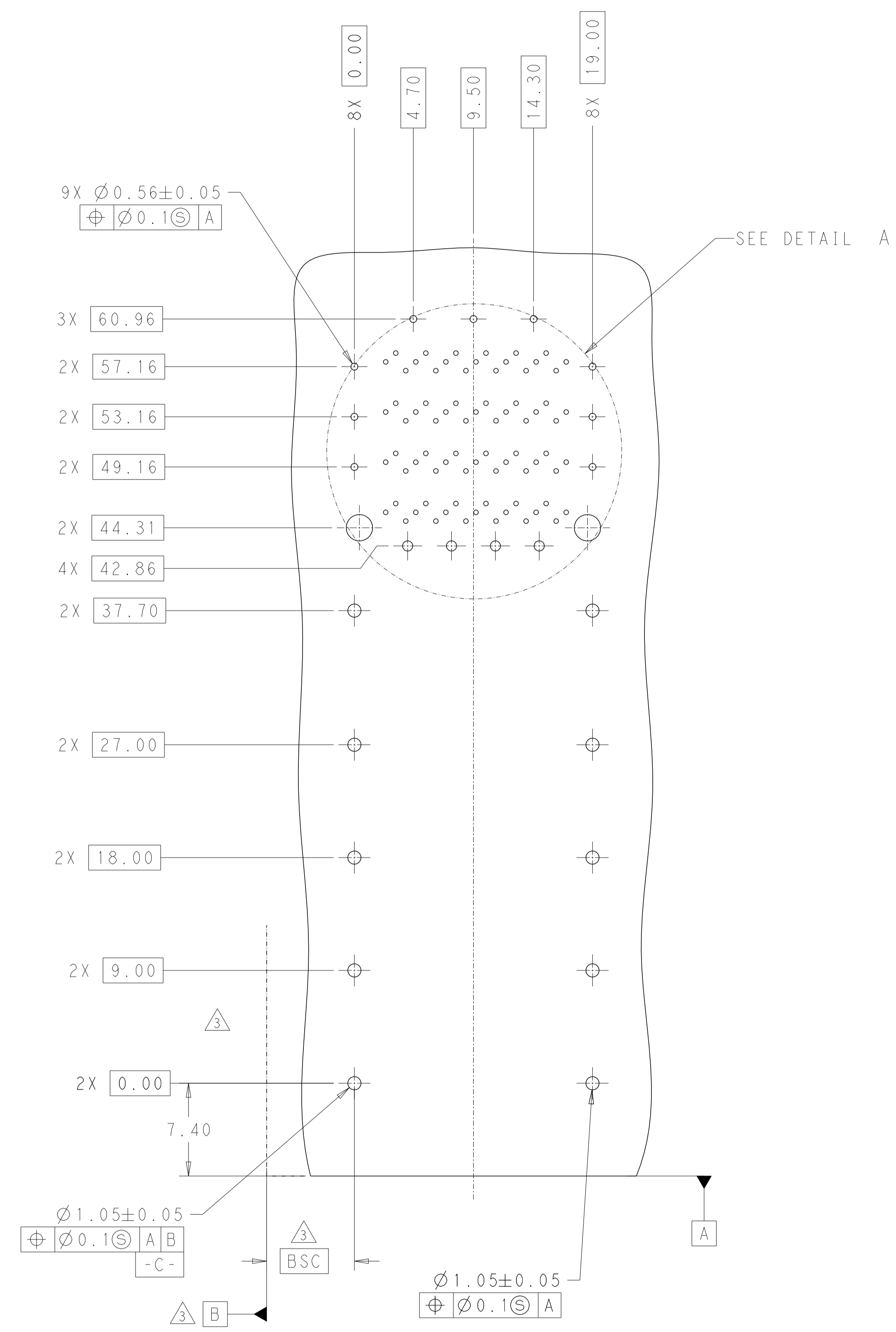

RECOMMENDED PC BOARD LAYOUT
COMPONENT SIDE OF BOARD
PCB TOLERANCE: ±0.05

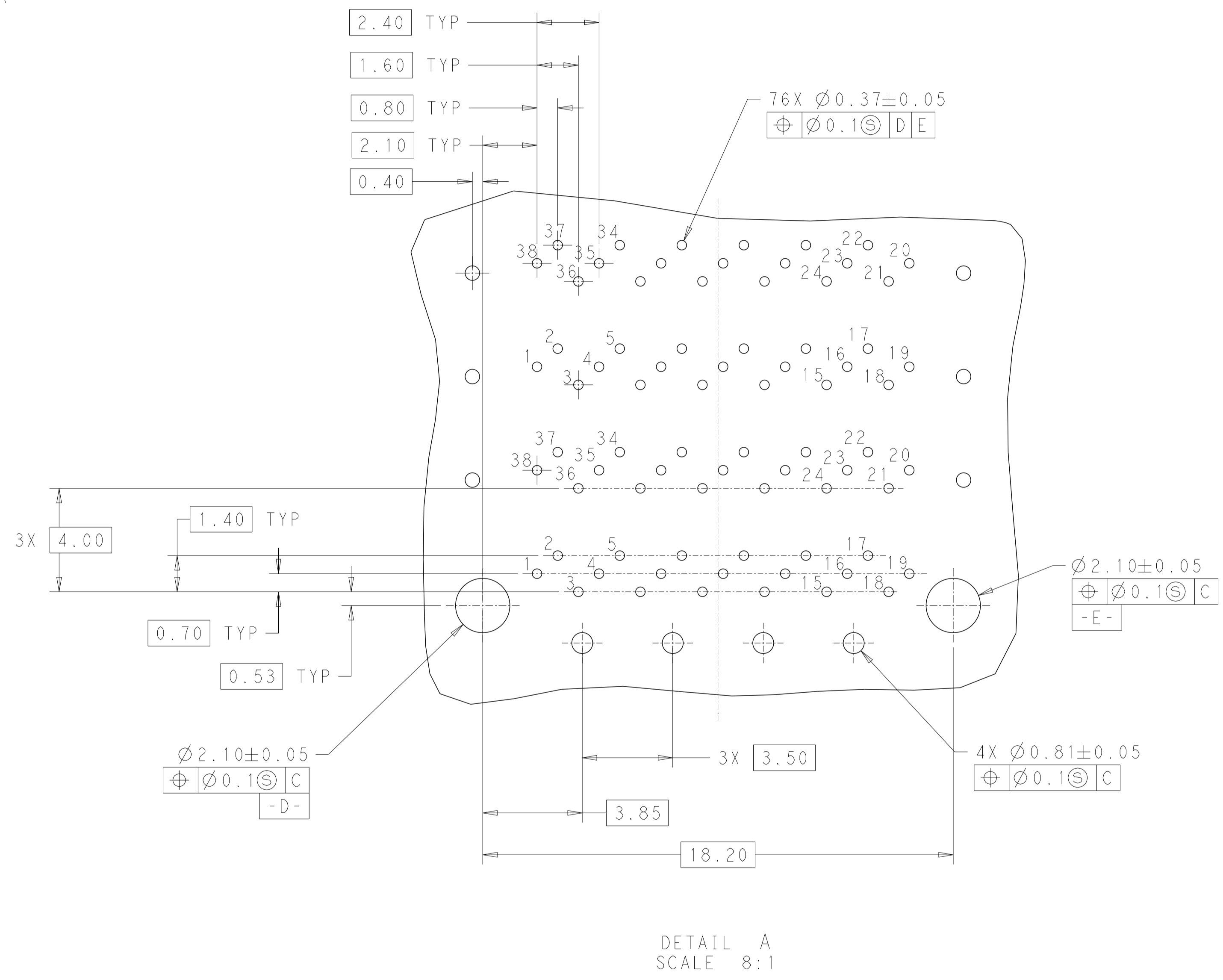

DETAIL A
SCALE 8:1

PRELIMINARY - NOT RELEASED FOR PRODUCTION

THIS PRODUCT HAS NOT COMPLETED VALIDATION AND QUALIFICATION TESTING

THIS DRAWING IS A CONTROLLED DOCUMENT.		OWN: REVIN DING 170CT13	TE Connectivity
DIMENSIONS: mm		CHK: JASON YANG 170CT13	
		APVD: JASON YANG 170CT13	NAME: CAGE AND CONNECTOR ASSEMBLY, WITH EMI GASKET, 2X1, THERMAL FOOTPRINT, ZQSFP+STACKED
TOLERANCES UNLESS OTHERWISE SPECIFIED:		PRODUCT SPEC	APPLICATION SPEC
0 PLC ±0.25 1 PLC ±0.15 2 PLC ±0.13 3 PLC ±0.10 4 PLC ±0.08 ANGLES ±0.0001°		WEIGHT	RESTRICTED TO
MATERIAL: SEE NOTE 1		FINISH: SEE NOTE 2	SIZE: A1
CUSTOMER DRAWING		SCALE: 4:1	SHEET: 3 OF 4
		DRAWING NO: 2170608	REV: 4

REVISIONS				
P	LTN	DESCRIPTION	DATE	APVD
-	-	SEE SHEET 1	-	-

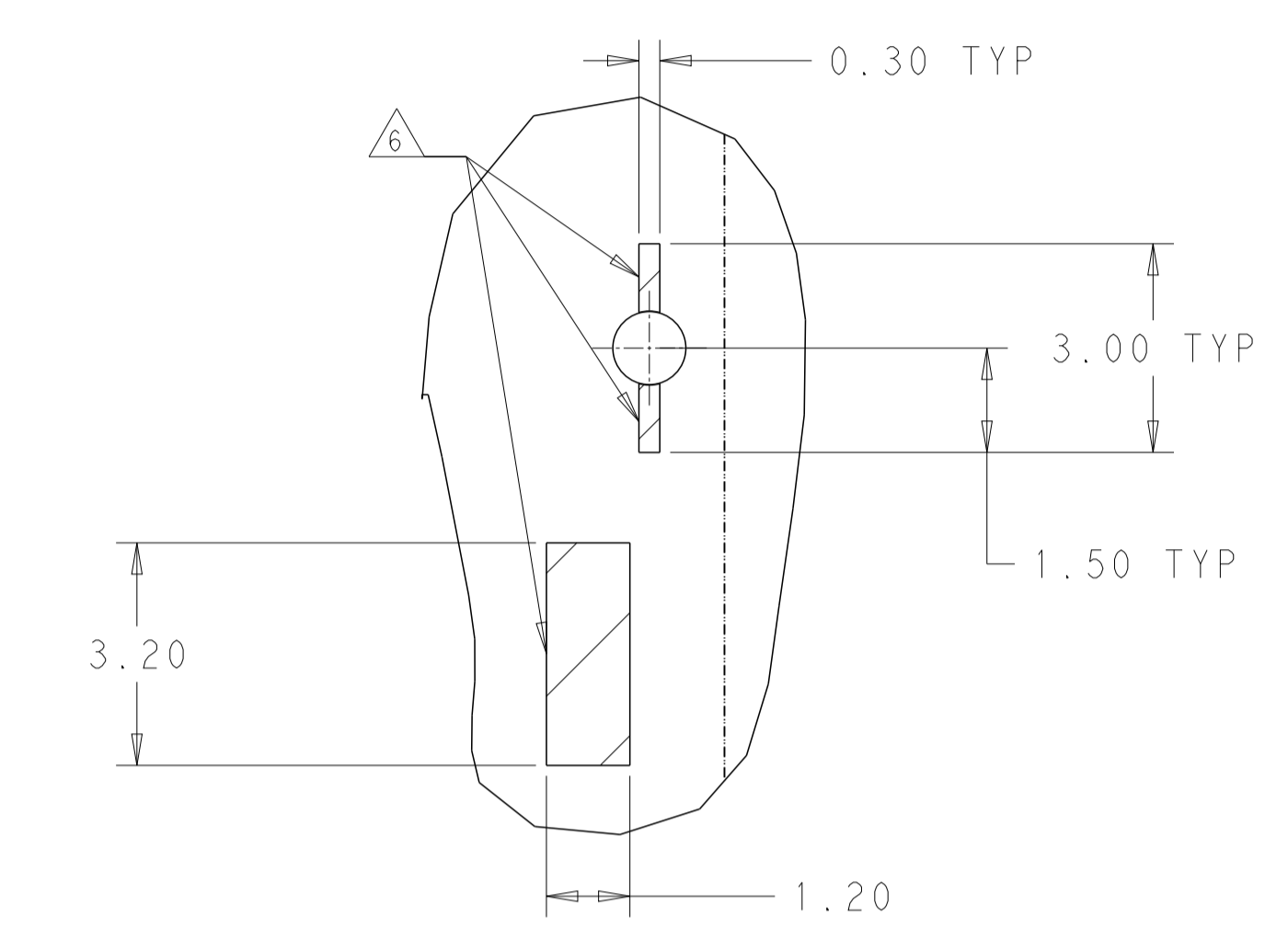
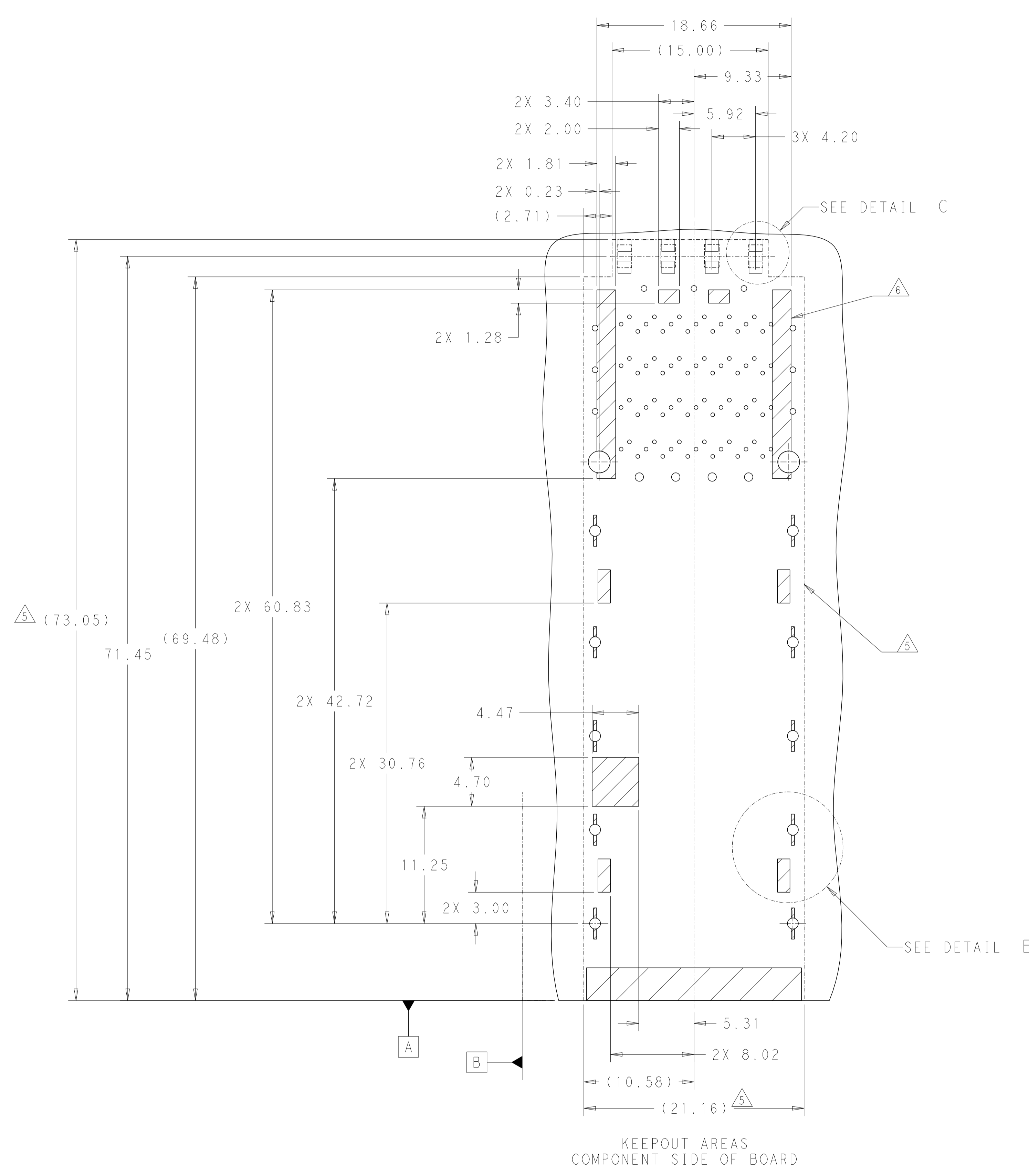

DETAIL B
SCALE 10:1

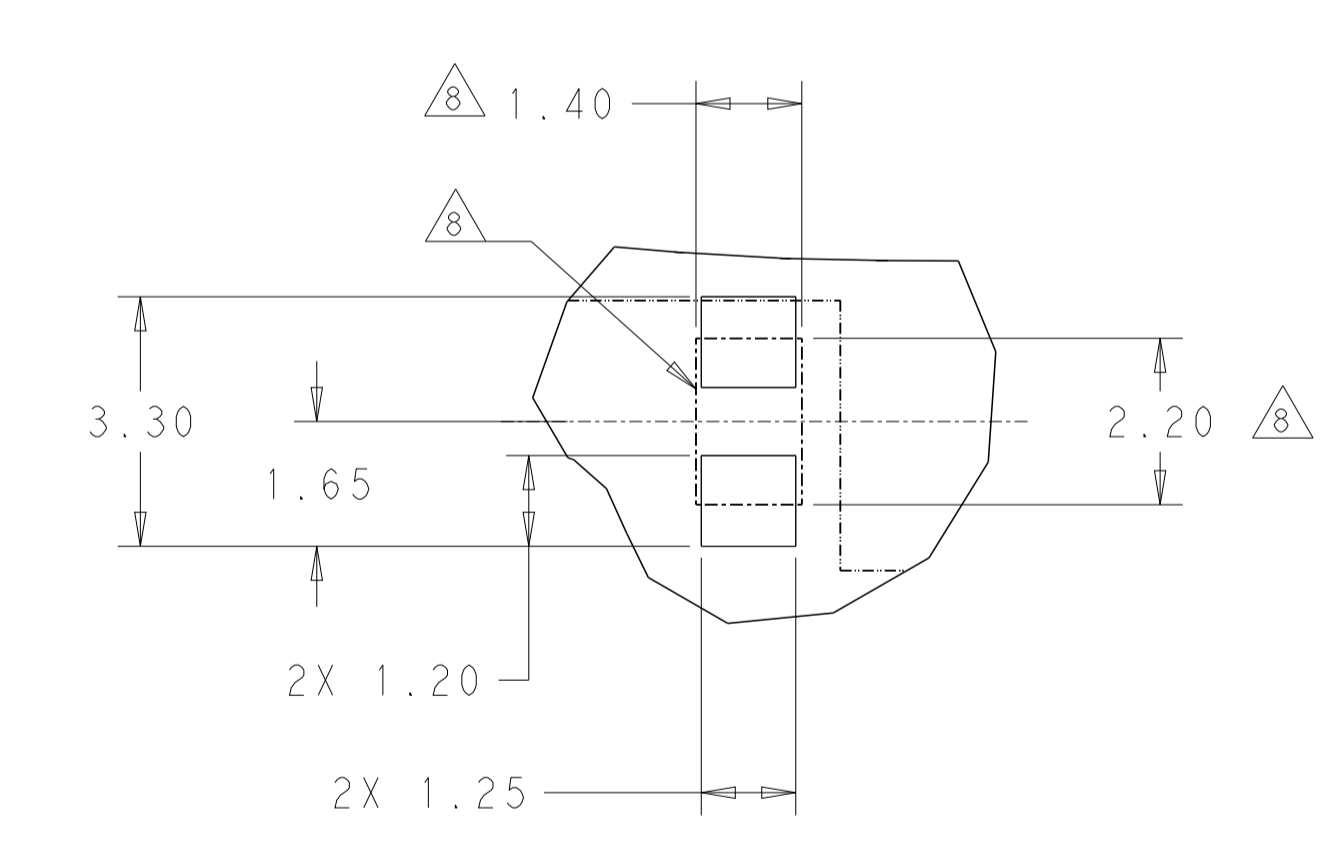

DETAIL C
SCALE 10:1

PRELIMINARY - NOT RELEASED FOR PRODUCTION

THIS PRODUCT HAS NOT COMPLETED VALIDATION AND QUALIFICATION TESTING

THIS DRAWING IS A CONTROLLED DOCUMENT.		OWN: REVIN DING 170CT13	TE Connectivity
DIMENSIONS: mm		CHK: JASON YANG 170CT13	
TOLERANCES UNLESS OTHERWISE SPECIFIED:		APVD: JASON YANG 170CT13	NAME: CAGE AND CONNECTOR ASSEMBLY, WITH EMI GASKET, 2X1, THERMAL FOOTPRINT, ZQSFP+STACKED
0 PLC ±0.25	1 PLC ±0.15	PRODUCT SPEC	APPLICATION SPEC
2 PLC ±0.13	3 PLC ±0.001	APPLIC. SPEC	RESTRICTED TO
4 PLC ±0.001	ANGLES ±2°	FINISH	WEIGHT
MATERIAL: SEE NOTE 1	FINISH: SEE NOTE 2	WEIGHT	SCALE: 4:1
CUSTOMER DRAWING		SIZE: A1	CAGE CODE: 00779
		DRAWING NO: C=2170608	SHEET 4 OF 4
			REV 4