

THIS DRAWING IS UNPUBLISHED. RELEASED FOR PUBLICATION
 © COPYRIGHT - By - ALL RIGHTS RESERVED.

LOC		DIST		REVISIONS			
P	LTR	DESCRIPTION		DATE	DWN	APVD	
AD	00	G2	REVISED PER ECR-14-016256		31OCT2014	ML	SZ

- 1 MATERIAL: ZINC ALLOY DIE CASTING.
- 2 FINISH: CHROMATE CONVERSION COATING. (ROHS COMPATIBLE).
- 3 FINISH: NICKEL PLATING
- 4 TOLERANCE ON DIMENSION "C" IS ±0.05MM

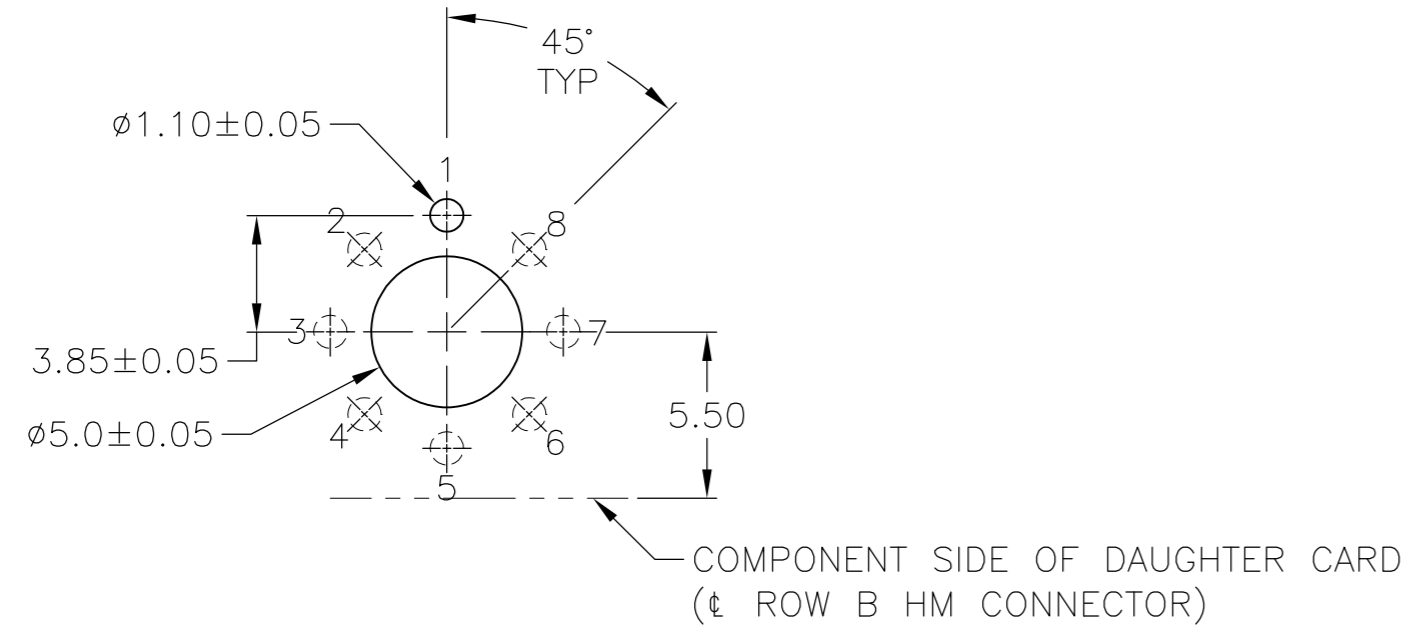
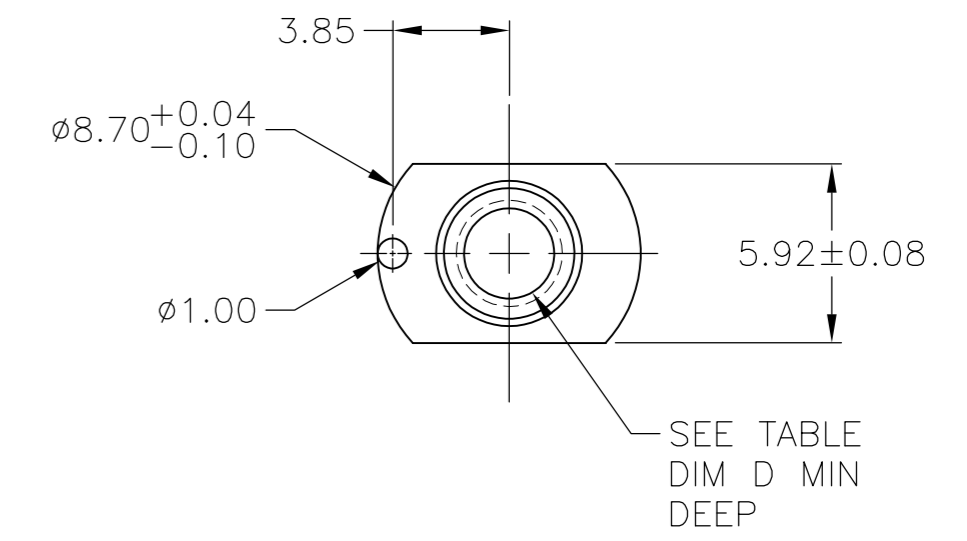
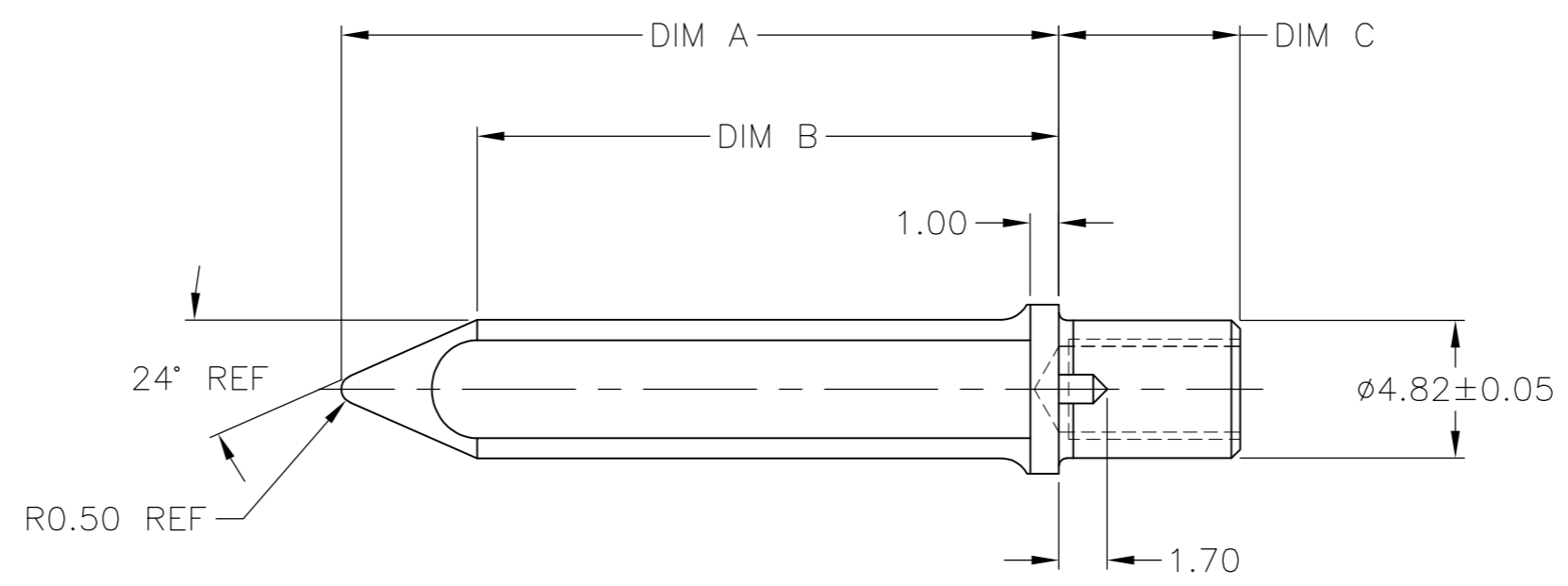
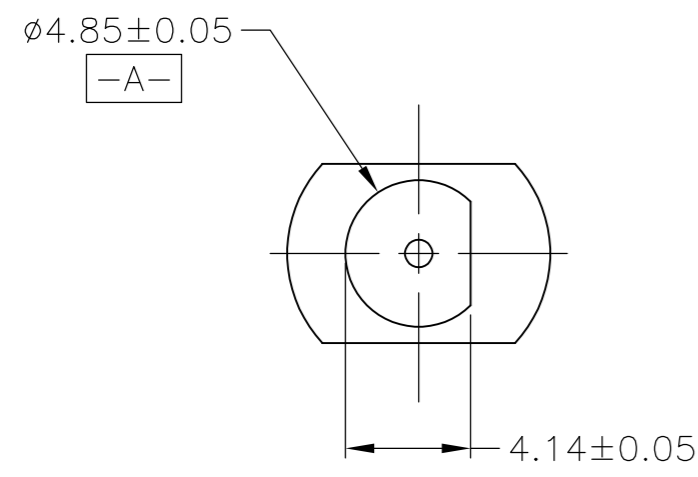

THREAD TYPE	DIM D	DIM C	DIM B	DIM A	FINISH	MATERIAL	PART NUMBER
6-32UNC-2B	4.0	3.5	20.39	25.16	2	1	1-5223985-0
6-32UNC-2B	2.9	2.4	20.39	25.16	2	4	5223985-9
6-32UNC-2B	4.65	5.0	20.39	25.16	2	1	5223985-8
4-40UNC-2B	2.6	1.7	20.39	25.16	2	1	5223985-7
6-32UNC-2B	4.65	5.0	20.39	25.16	2	3	5223985-6
6-32UNC-2B	2.2	1.7	20.39	25.16	2	1	5223985-5
6-32UNC-2B	3.45	3.8	20.39	25.16	2	1	5223985-4
6-32UNC-2B	3.0	6.35	24.23	29.00	2	1	5223985-3
6-32UNC-2B	6.0	6.35	20.39	25.13	2	1	5223985-1

RECOMMENDED P.C. BOARD LAYOUT
 (POSITION SHOWN USED WITH P/N 223986-1)

THIS DRAWING IS A CONTROLLED DOCUMENT.

DIMENSIONS: mm	TOLERANCES UNLESS OTHERWISE SPECIFIED:	DWN J. POLIGNONE 05APR05	TE Connectivity
	0 PLC ± - 1 PLC ± - 2 PLC ± 0.13 3 PLC ± - 4 PLC ± - ANGLES ± 0°30'	CHK R.PATTERSON 05APR05	
MATERIAL SEE TABLE	FINISH SEE TABLE	APVD R.PATTERSON 05APR05	NAME R.PATTERSON
		PRODUCT SPEC	SIZE A2 CAGE CODE 00779 DRAWING NO C=5223985
		APPLICATION SPEC	RESTRICTED TO
		WEIGHT -	SCALE 1:1 SHEET 1 OF 1 REV G2
		CUSTOMER DRAWING	