

---

## SPC58EC-DISP discovery board

### Introduction

The SPC58EC-DISP discovery plus board is a development board to evaluate and develop applications with the microcontroller SPC58EC80E5 in eTQFP144 package.

The SPC58EC80E5 is a microcontroller targeting body, networking and security applications.

This document describes the hardware architecture of the board and how it is possible to enable specific functions through the configuration of the jumpers.

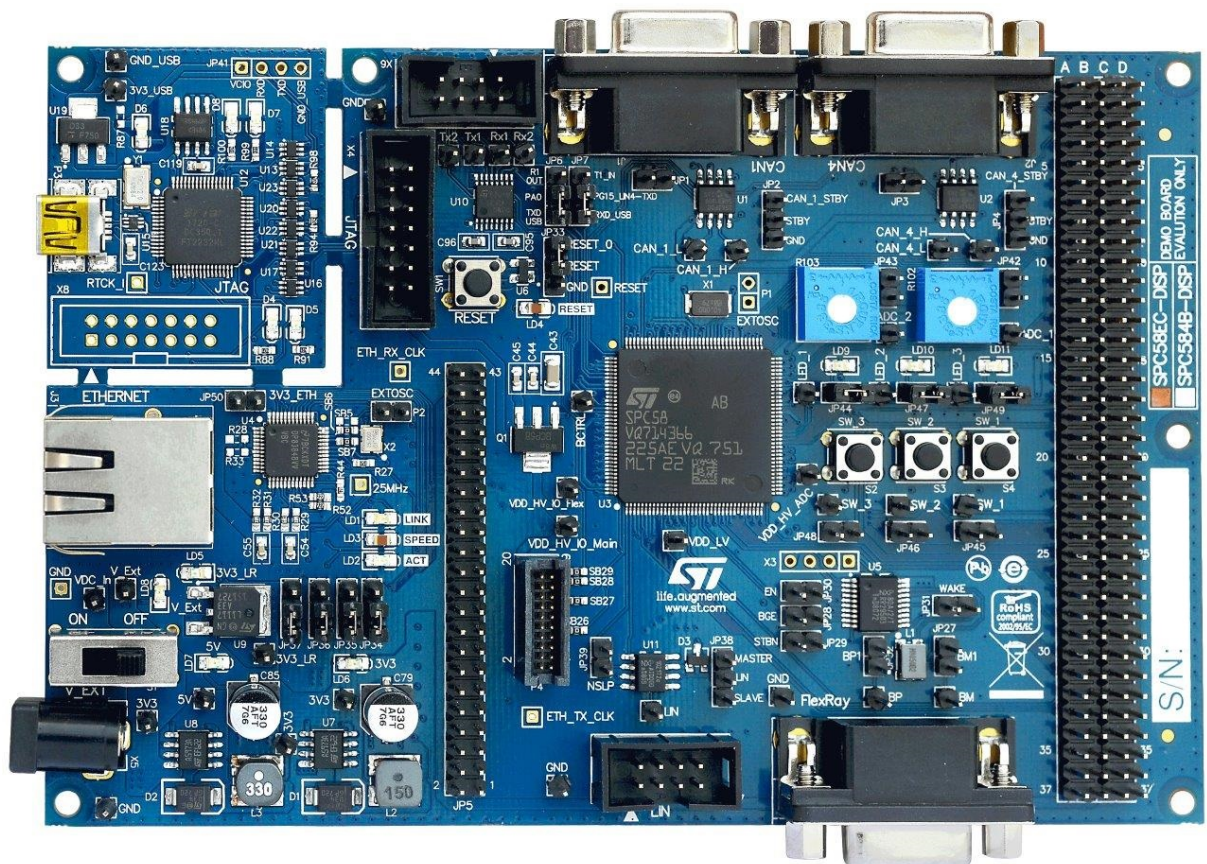
# 1 Overview

The several interfaces including Ethernet controller, CAN-FD, FlexRay, LIN and UART, ADC, and JTAG port make the SPC58EC-DISP an excellent tool to evaluate the microcontroller as well as to develop and then debug applications.

An integrated programmer debugger (supported PLS) allows debugging and programming the microcontroller. The same section allows enabling a USB virtual COM port.

Dedicated connectors allow plugging shields Arduino UNO R3-compatible. This feature makes it simple to expand the board functionality adding a shield or board available on the market. All GPIOs and main signals are accessible by a 4x37 0.1" pin array.

Figure 1. SPC58EC-DISP discovery board-top side



## 2 License agreement

---

The packaging of this evaluation board was sealed with a seal stating, by breaking this seal, you agree to the terms and conditions of the evaluation board license agreement, the terms and conditions of which are available at [https://www.st.com/resource/en/evaluation\\_board\\_terms\\_of\\_use/evaluationproductlicenseagreement.pdf](https://www.st.com/resource/en/evaluation_board_terms_of_use/evaluationproductlicenseagreement.pdf). Upon breaking the seal, you and STMicroelectronics entered into the evaluation board license agreement, a copy of which is also enclosed with the evaluation board for convenience.

**Attention:** *This evaluation board only offers limited features for evaluating ST products. It has not been tested for use with other products and is not suitable for any safety or other commercial or consumer application. This evaluation board is otherwise provided "AS IS" and STMicroelectronics disclaims all warranties, express or implied, including the implied warranties of merchantability and fitness for a particular purpose.*

### 3 Handling precautions

---

Please take care to handle the package content in order to prevent electrostatic discharge.

Before the EVB is used or power is applied, please fully read the following sections on how to correctly configure the board. Failure to correctly configure the board may cause irreparable component, MCU or EVB damage.

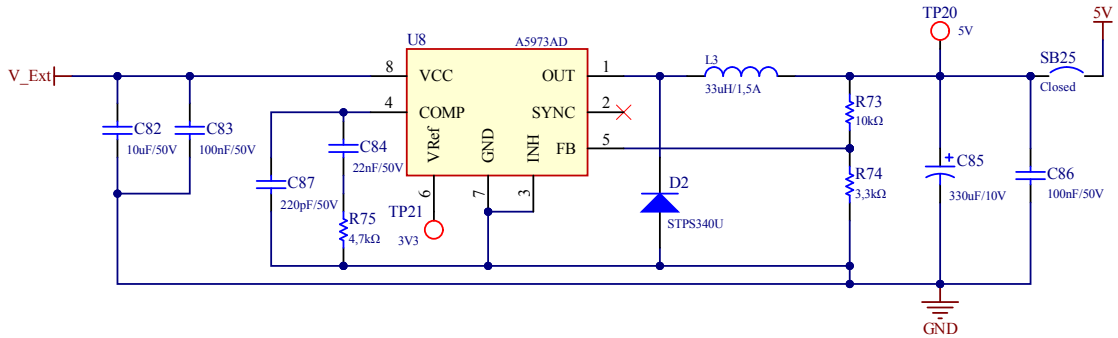
## 4 Hardware overview

### 4.1 Power supply section

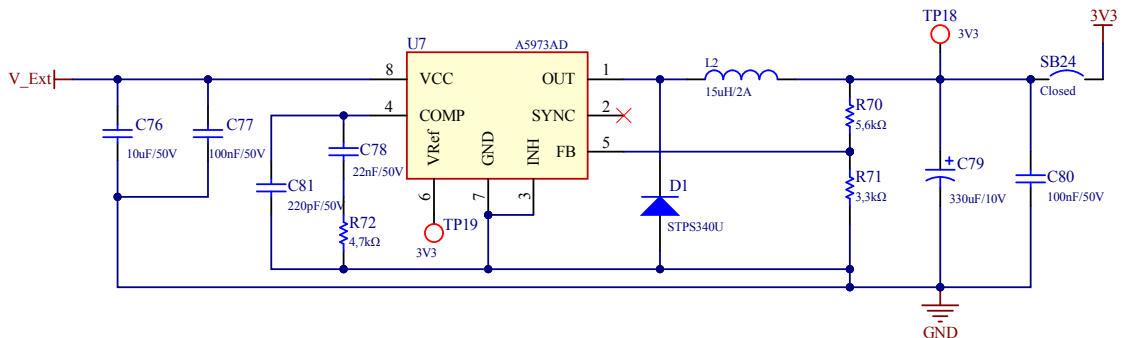
The input voltage level is 12 V<sub>DC</sub>, the output voltage is set to 5 V and 3.3 V.

The Figure 2 and Figure 3 show the buck converters used to generate 5 V and 3.3 V respectively.

**Figure 2. 12 V - 5 V buck converter**

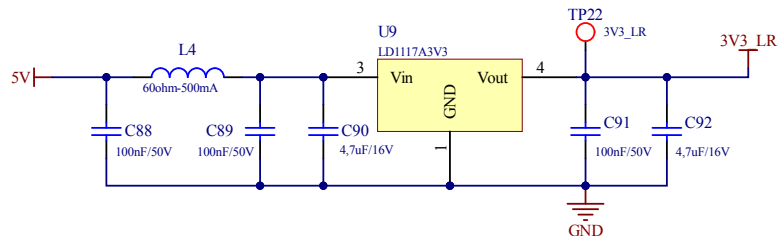


**Figure 3. 3.3 V buck converter**



The Figure 4 shows a 3.3 V linear regulator; it is suitable to supply the ADC section.

**Figure 4. 3.3 V linear converter**

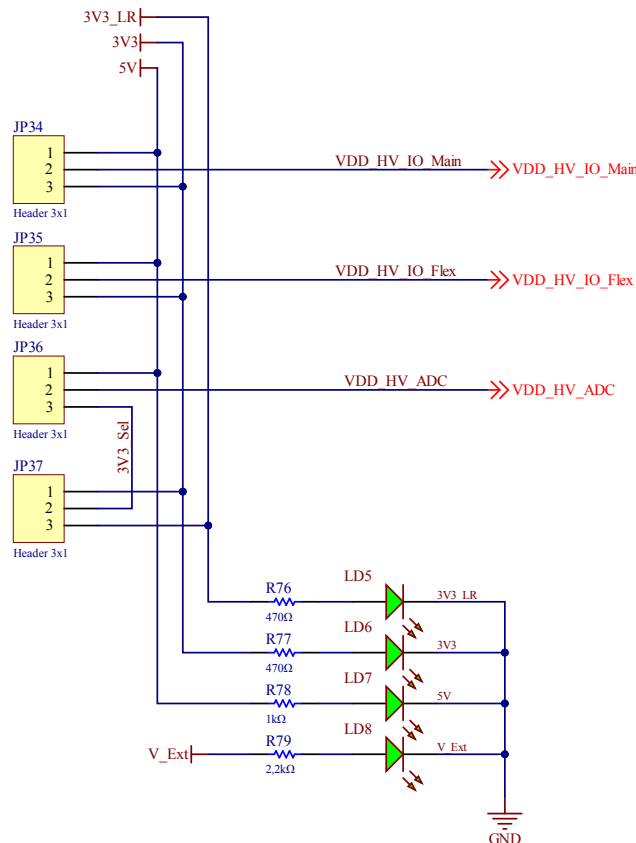


## 4.2 Microcontroller power management

The JP34 allows selecting the voltage level to supply VDD\_HV\_IO\_main (5 V or 3.3 V); as well as JP35 sets the VDD\_HV\_IO\_Flex level. The JP36 sets the VDD\_HV\_ADC supply level; JP37 sets the 3.3 V source (from linear or switching regulator). These jumpers allow the evaluation of the current absorption.

The LEDs D5, D6, D7 and D8 provide feedback about the status of the power supply section.

**Figure 5. Power supply selector and LEDs**



## 4.3 Integrated programmer/debugger

The integrated programmer/debugger allows the user to program the microcontroller, build, and debug the software applications. The debugger works with the UDE PLS software.

The debugger serial number is a label applied on the PCB bottom side.

The integrated debugger SW is accessible via ST's free integrated development environment, SPC5Studio ([www.st.com/spc5studio](http://www.st.com/spc5studio)). To download the debugger software and activate the license refer to the PLS website.

The core of the debugger is a single chip USB to dual serial/parallel ports. A portion of the device manages the JTAG signals while the second part implements a UART communication channel; the level shifters are necessary to balance the signals levels (3.3 V ↔ 5 V).

The supply comes from the PC through the USB cable and a dedicated 3.3 V linear regulator supplies this section.

The microcontroller can be programmed and debugged also by using external tools connected to a JTAG port (2x7 pin). The solder jumper from SB8 to SB14 allows disconnecting the JTAG signal from the integrated debugger.

**Note:**

*An external debugger must be used with the USB cable disconnected and under this working condition; the integrated debugger is not supplied. If the external programmer does not work properly, the jumpers SB8÷SB14 must be removed (open). It is suggested to perform some tests before removing the jumpers SB8÷SB14.*

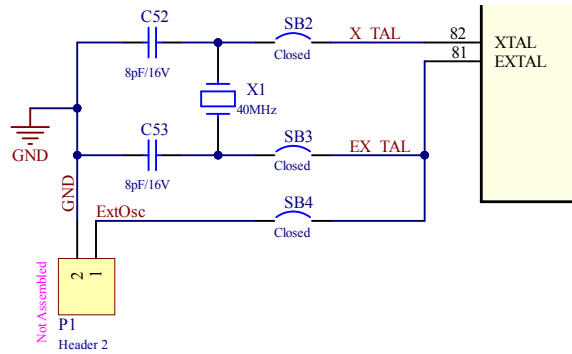
The SPC58EC-DISP comes with the integrated programmer enabled (all solder jumpers from SB8 to SB14 are present).

## 4.4 Crystal oscillator and reset

The Figure 6 shows the external oscillator circuit; the frequency is 40 MHz.

By setting SB2, SB3 (open) and SB3 (closed) it is possible to drive the EXTAL pin with an external clock.

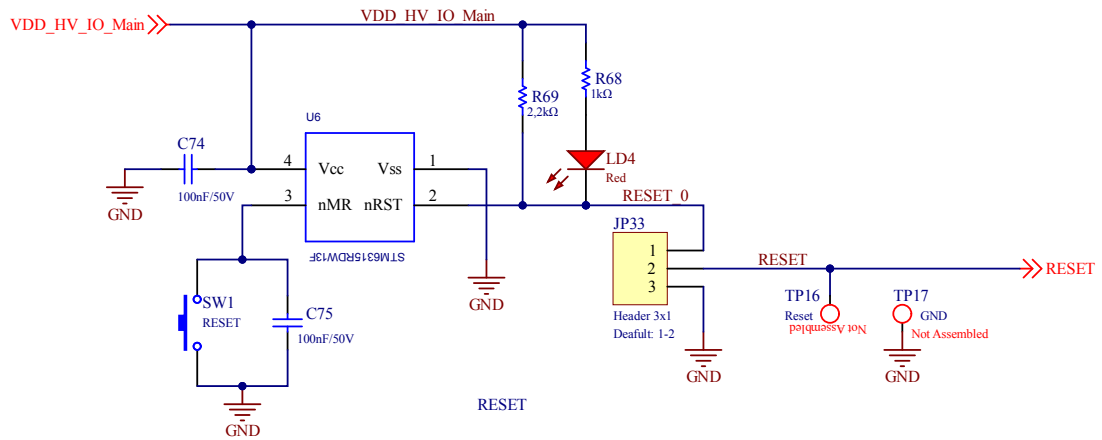
**Figure 6. Crystal oscillator**



The reset circuit is the device STM6315.

The STM6315 (see Figure 7) asserts a reset signal whenever the  $V_{CC}$  pin drops below 2.63 V and keep it asserted until the level of  $V_{CC}$  has risen above the threshold for a 210 ms.

**Figure 7. Reset circuit**



The device generates a reset signal when the SW1 button is pressed.

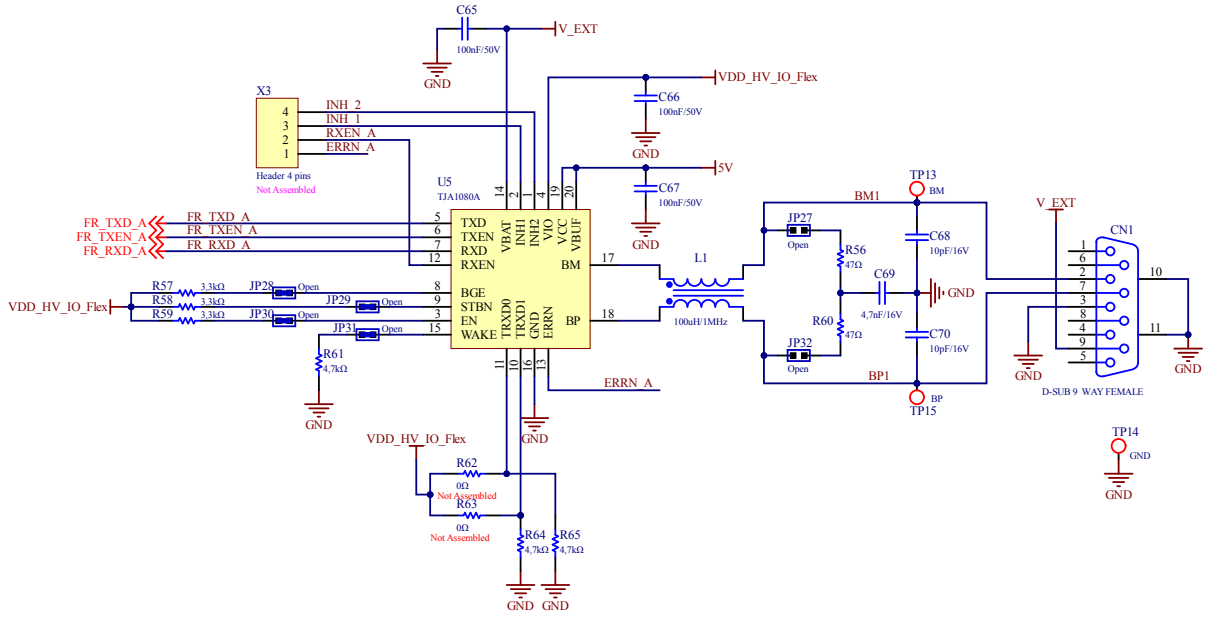
The reset output is an open drain pin and it must be pulled-up to  $V_{DD\_CPU}$  voltage level (R69). The LD4 provides feedback when the reset pulse is generated.

## 4.5 FlexRay

The Figure 8 shows the FlexRay section (transceiver + DB9 connector).

The jumpers JP27 and JP32 connect the load terminations (47  $\Omega$ ). The jumpers from JP28 to JP31 allow configuring the transceiver.

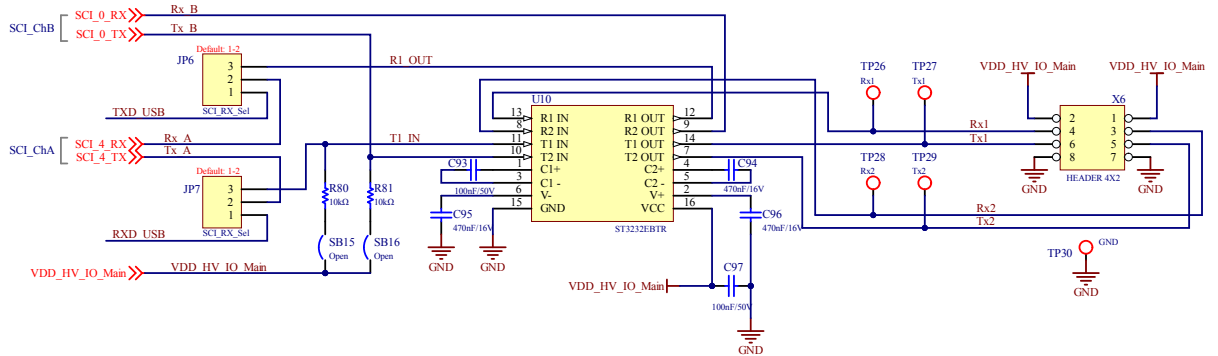
Figure 8. FlexRay



#### 4.6 RS232 and LIN

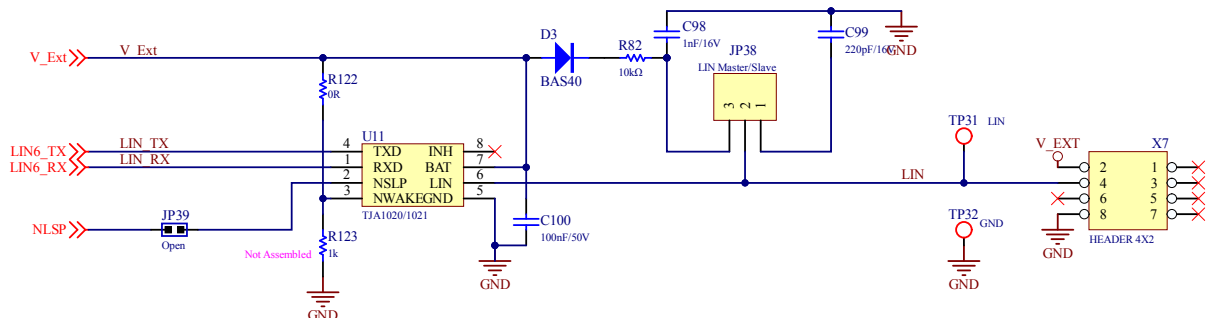
Two serial communication channels are available; U10 is a dual RS232 driver and receiver (see Figure 9).

Figure 9. RS232 section



The Figure 10 shows the LIN circuit; JP38 allows setting master/slave mode.

Figure 10. LIN section





### 4.7 CAN and ISO CAN-FD

Two CAN channels are available, both are based on a fast transceiver; the implemented solution is compatible with the CAN-FD operation standard.

The jumper JP2 allows the selection in normal or standby mode:

- No jumper: normal operation<sup>(1)</sup>
- Jumper 2-3: device in standby mode (manual or fixed selection)
- Jumper 1-2: microcontroller drives the standby (dynamic configuration)
- Jumper JP1 enables the load termination

1. In the transceiver, an internal pull-up resistor is already present and R1 could be removed.

### 4.8 Ethernet

JP5 allows connecting the Ethernet transceiver to the microcontroller to implement RII or MII communication protocol.

JP5 allows the implementation of another feature: its pins allow plugging an addition board to evaluate the communication performance by using a different Ethernet physical layer.

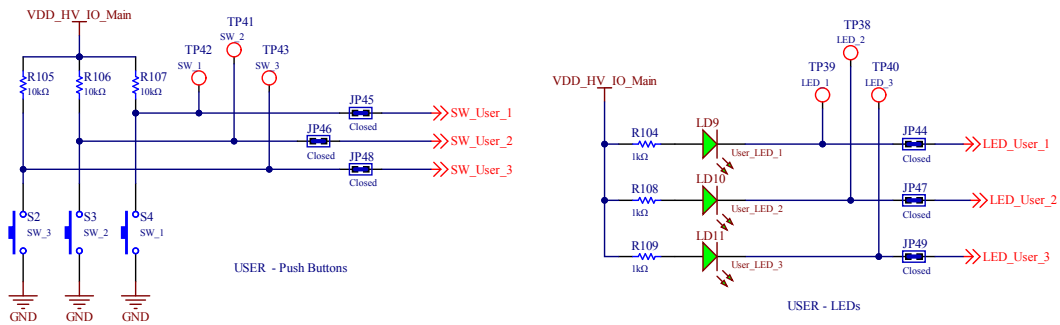
The R29 ÷ R32 are the load termination resistors.

*Note:* The level of the transceiver in/out pins is 3.3 V then the microcontroller supply level must be set consequently.

### 4.9 User interface (pushbuttons, LEDs and trimmers)

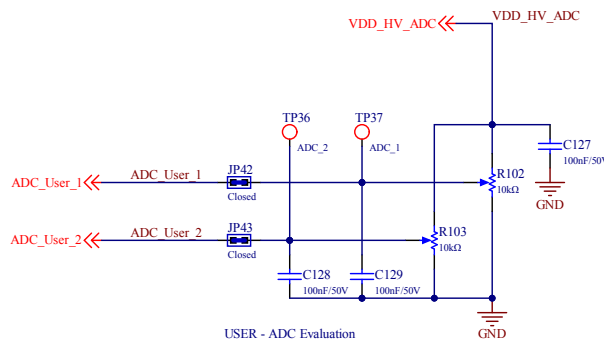
In the board three LEDs and three push-buttons are present and they are suitable for user purposes (see Figure 11).

Figure 11. User pushbutton and LEDs



Two trimmers allow the evaluation of the ADC performance (see Figure 12).

Figure 12. Trimmers



## 4.10 Extended connectors (I/O headers)

Most of the GPIOs and signals are accessible by the connector X9, a 4x37 male pin array allowing connection of additional boards and with the user HW application. The [Table 1](#) and [Table 2](#) summarize the function and signal of each pin.

**Table 1. X9 (part I) - Extended connectors (I/O headers)**

X9 pinA	Function/Port pinA	X9 pinB	Function/Port pinB
A1	GND	B1	5 V
A2	PD10_eMIOS0-UC23	B2	PA13_eMIOS-UC13
A3	PD9_eMIOS1-UC3	B3	PH2_GPIO114
A4	PB2_eMIOS0-UC8	B4	PH4_GPIO116
A5		B5	
A6		B6	
A7	PA4_DSPI1-CS0	B7	PD6_DSPI1-SCK
A8		B8	
A9	PC3_eMIOS0-UC7	B9	PA15_DSIP0-CS1
A10	PE10_LIN_0_RXD	B10	PD11_eMIOS0-UC21
A11	PE9_eMIOS0-UC9	B11	PK14_GPIO174
A12	RESET	B12	
A13		B13	
A14	PE1_eMIOS0-UC12	B14	
A15	PA12_DSPI2-CS0	B15	PH0_DSPI2-SCK
A16	PB9_DSPI2-SIN	B16	PB10_DSPI2-SOUT
A17	PF7_CAN4sys1-TX	B17	PF6_CAN4sys1-RX
A18	PG1_FR_RXD_A	B18	PI9_FR_TXD_A
A19	PD1_I2C-SDA	B19	PD2_I2C-SCL
A20	PA11_CAN1sys0_RX	B20	PA10_CAN1sys0_TX
A21	PI8_FR_TXEN_A	B21	PA0_LIN4-RXD
A22	PF11_SW_User_1	B22	PF0_eMIOS1-UC2
A23	PF12_SW_User_2	B23	
A24	PF13_SW_User_3	B24	PG14_eMIOS1-UC0
A25	PF1_eMIOS1-UC1	B25	PC14_eMIOS-UC27
A26		B26	PI3_ADC-AN39
A27	PI5_ADC-AN41	B27	PI6_ADC-AN49
A28	PG3_ADC-AN26	B28	PD13_ADC-AN16
A29	PG4_ADC-AN27	B29	PG5_ADC-AN42
A30		B30	
A31	PE0_ADC_AN11	B31	PG12_ADC-AN58
A32	PE3_ADC-AN17	B32	PG10_ADC-AN55
A33		B33	
A34	PI2_eMIOS0-UC5	B34	PD5_DSPI0-SOUT
A35	PM14_GPIO206	B35	PE8_DSIP0-CS0

X9 pinA	Function/Port pinA	X9 pinB	Function/Port pinB
A36	PG15_LIN4-TXD	B36	5 V
A37	V_EXT_P	B37	V_EXT_P

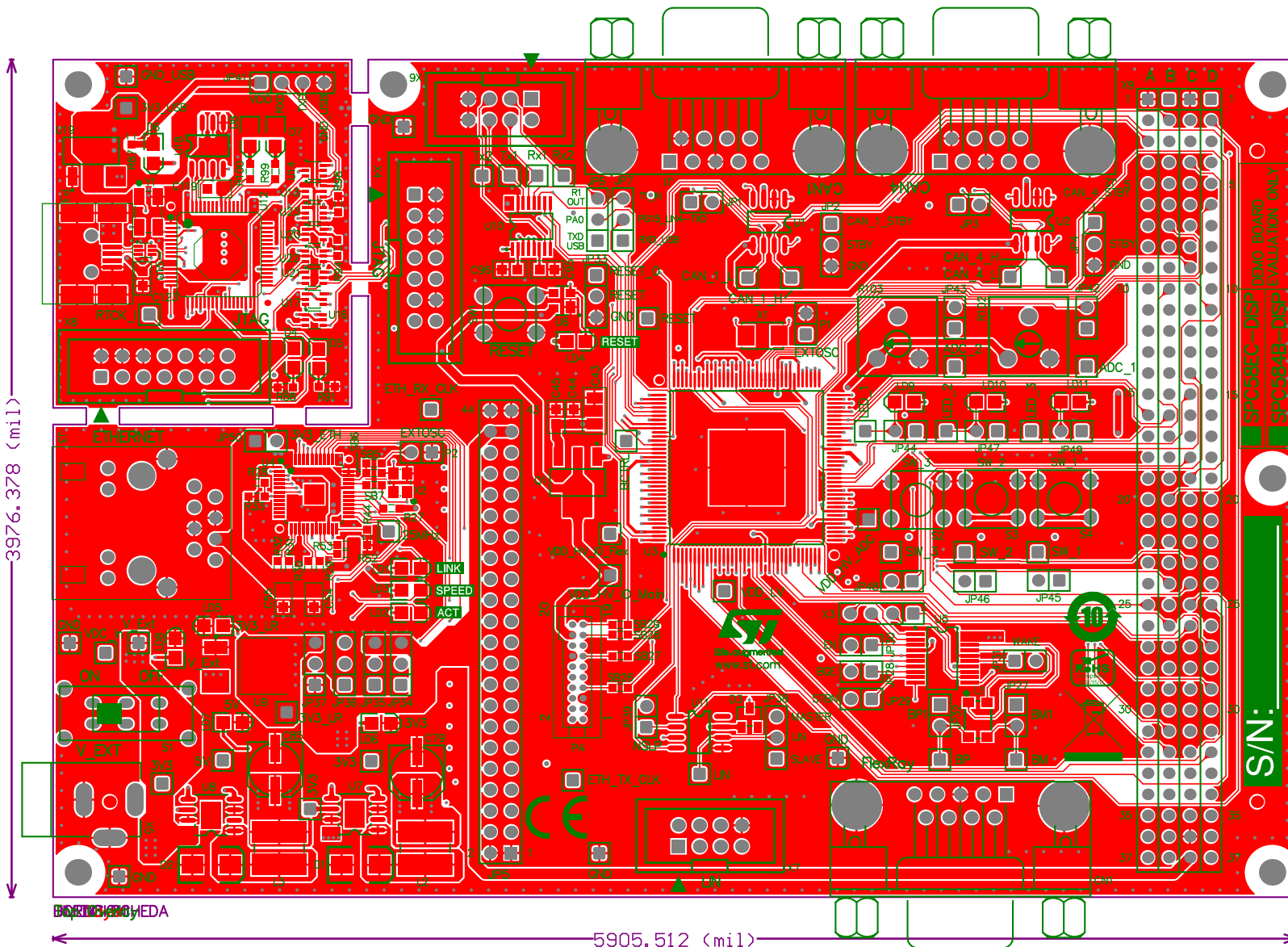
**Table 2. X9 (part II) - Extended connectors (I/O headers)**

X9 pinC	Function/Port pinC	X9 pinD	Function/Port pinD
C1	GND	D1	PE11_LIN_0_TXD
C2	PF3_eMIOS0-UC2	D2	PD15_LIN_6_RXD
C3	PF15_eMIOS1-UC28	D3	PB0_eMIOS1-UC28
C4	PE14_eMIOS1-UC26	D4	PG13_eMIOS1_UC31
C5		D5	PB1_GPIO17
C6	PC12_DSPI1-SOUT	D6	PD7_DSPI1-SIN
C7		D7	
C8	PB8_eMIOS0-UC27	D8	
C9	PA14_GPIO14	D9	PB3_ADC_User_1
C10		D10	PB4_ADC_User_2
C11	PK0_GPIO160	D11	PD14_LIN_6_TXD
C12		D12	
C13		D13	
C14	PI1_eMIOS0-UC4	D14	PF8_LED_User_1
C15	PE13_eMIOS0-UC30	D15	PF9_LED_User_2
C16		D16	PF10_LED_User_3
C17	PA2_CAN2sys0_TX	D17	PA1_CAN2sys0_RX
C18	PE6_CAN0sys0_RX	D18	PE5_CAN0sys0_TX
C19	PE7_LIN_1_TXD	D19	
C20		D20	PF2_EIRQ6
C21		D21	PB11_FCCU-F0
C22		D22	PC2_FCCU-F1
C23	PF14_GPIO94	D23	PA3_eMIOS0-UC28
C24	PA3_eMIOS0-UC28	D24	
C25	PC7_eMIOS0-UC3	D25	PD12_eMIOS0-UC14
C26	PK1_GPIO161	D26	PH1_GPIO113
C27	PI7_ADC-AN50	D27	PG2_ADC-AN25
C28	PG11_ADC-AN57	D28	PI4_ADC-AN40
C29	PG6_ADC-AN44	D29	PG9_ADC-AN53
C30	PB6_ADC-AN48	D30	PB7_ADC-AN47
C31	PD8_ADC-AN92	D31	
C32		D32	PL8_ADC-AN5
C33		D33	
C34	PE15_DSIP0-SIN	D34	PE2_ADC-AN13
C35		D35	PD4_DSPI0-SCK

X9 pinC	Function/Port pinC	X9 pinD	Function/Port pinD
C36	GND	D36	PM2_GPIO194
C37	3V3	D37	V_Ext

# 5 PCB layout

Figure 13. SPC58EC-DISP - PCB top side



# 6 Schematics

Figure 14. Power supply

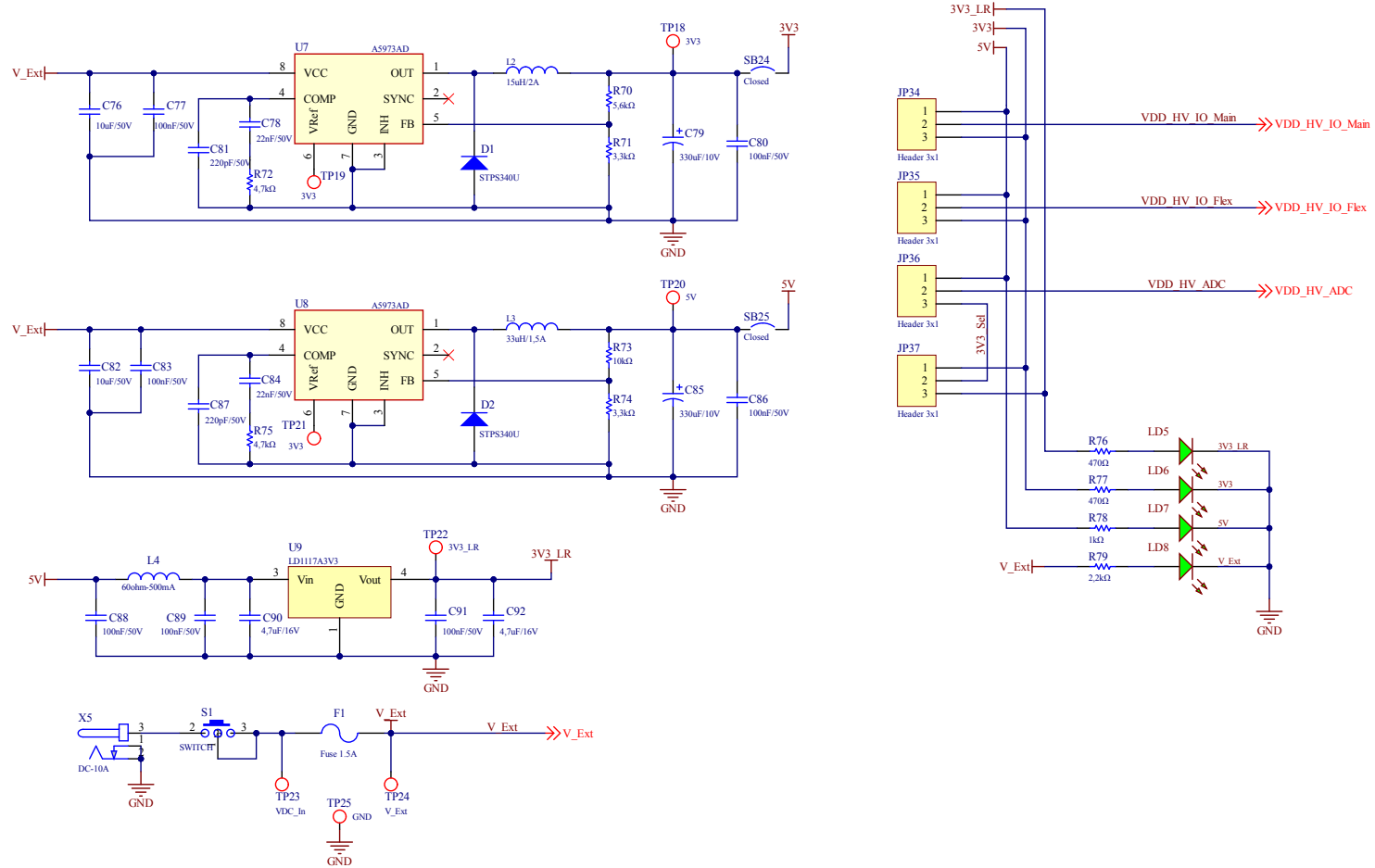


Figure 15. USB and debugger

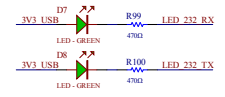
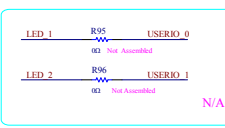
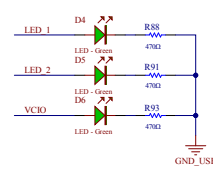
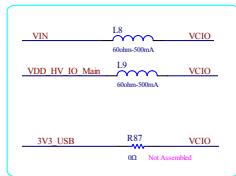
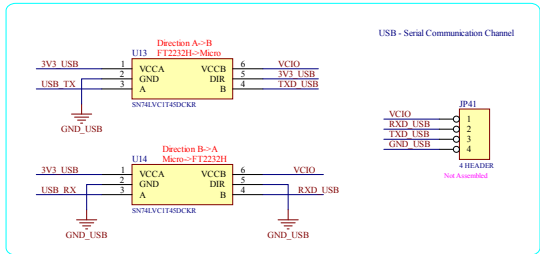
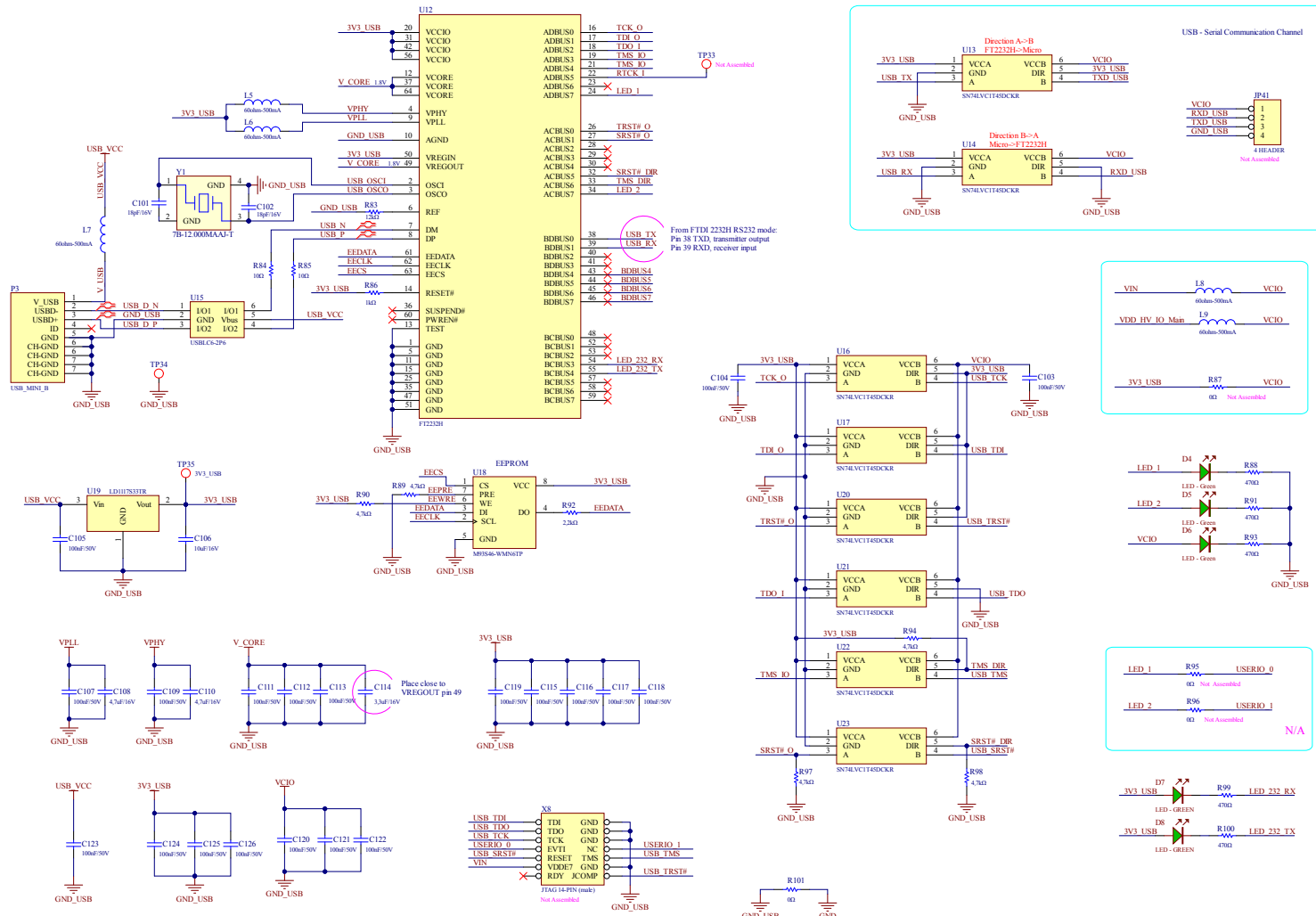


Figure 16. JTAG and reset

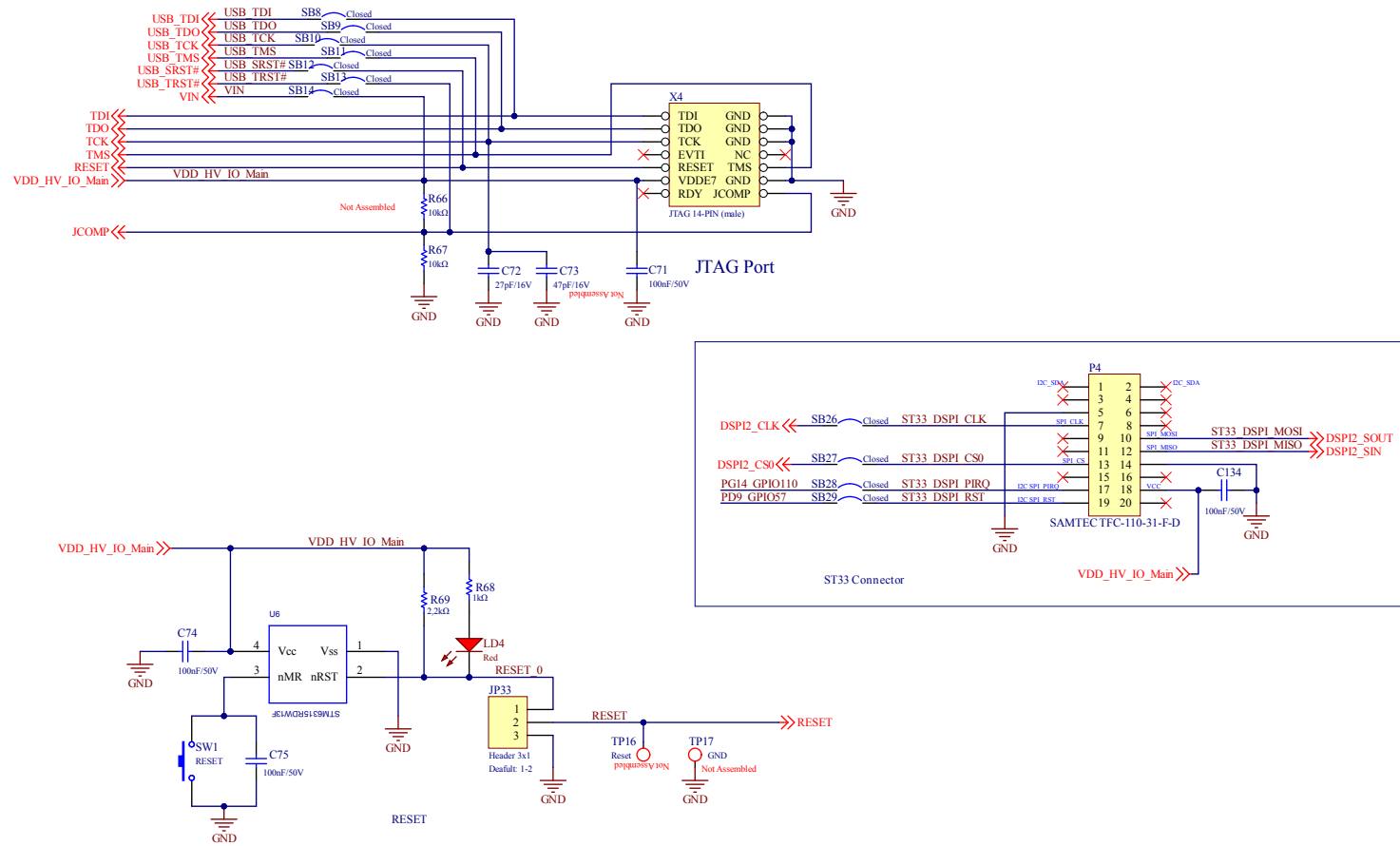




Figure 17. FlexRay

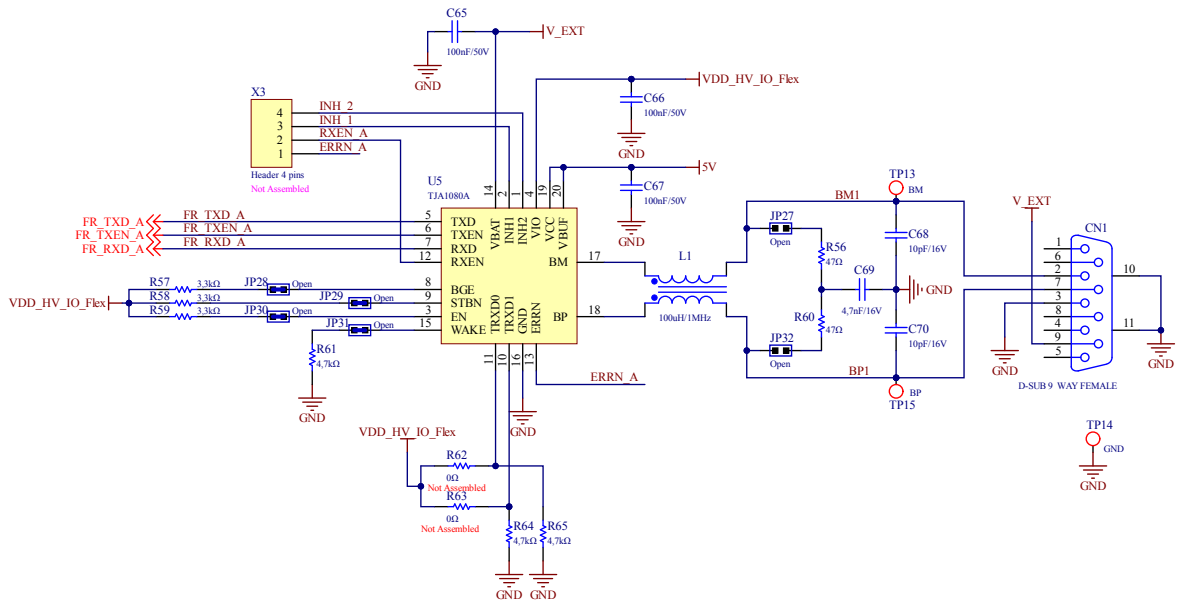


Figure 18. RS232 and LIN

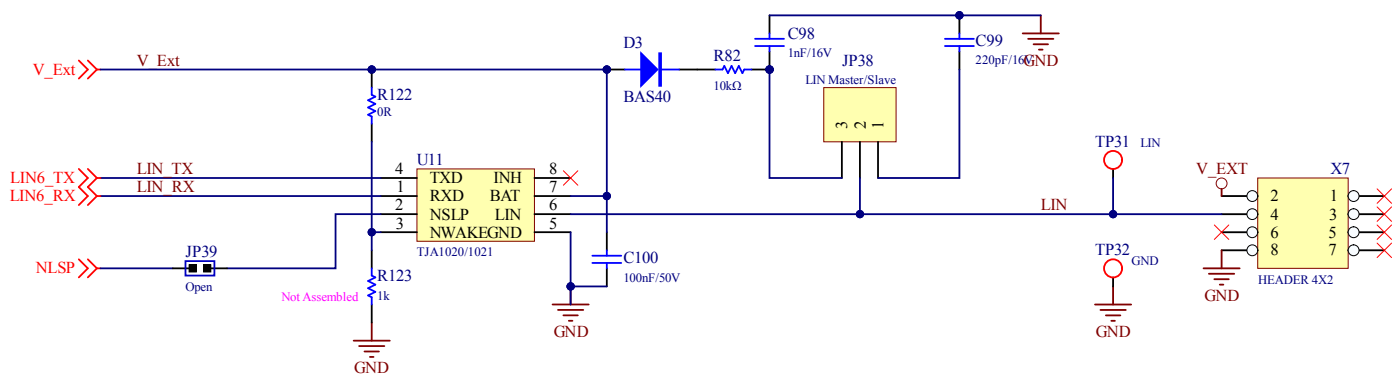
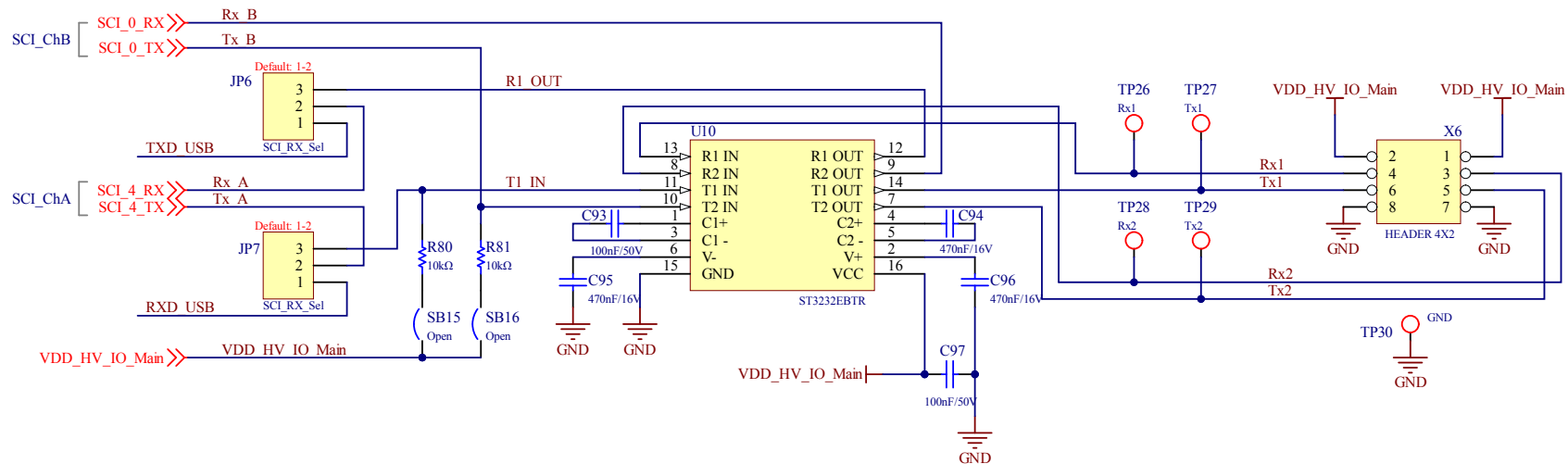


Figure 19. CAN and ISO CAN-FD

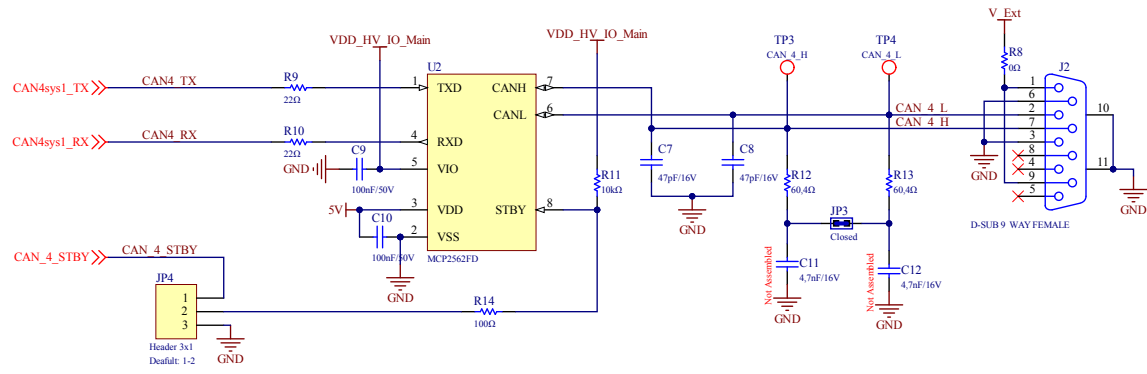
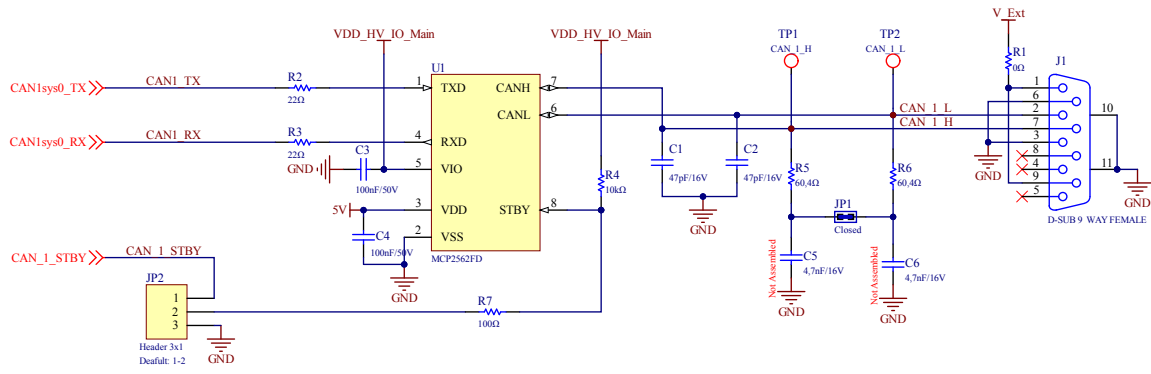


Figure 20. Ethernet

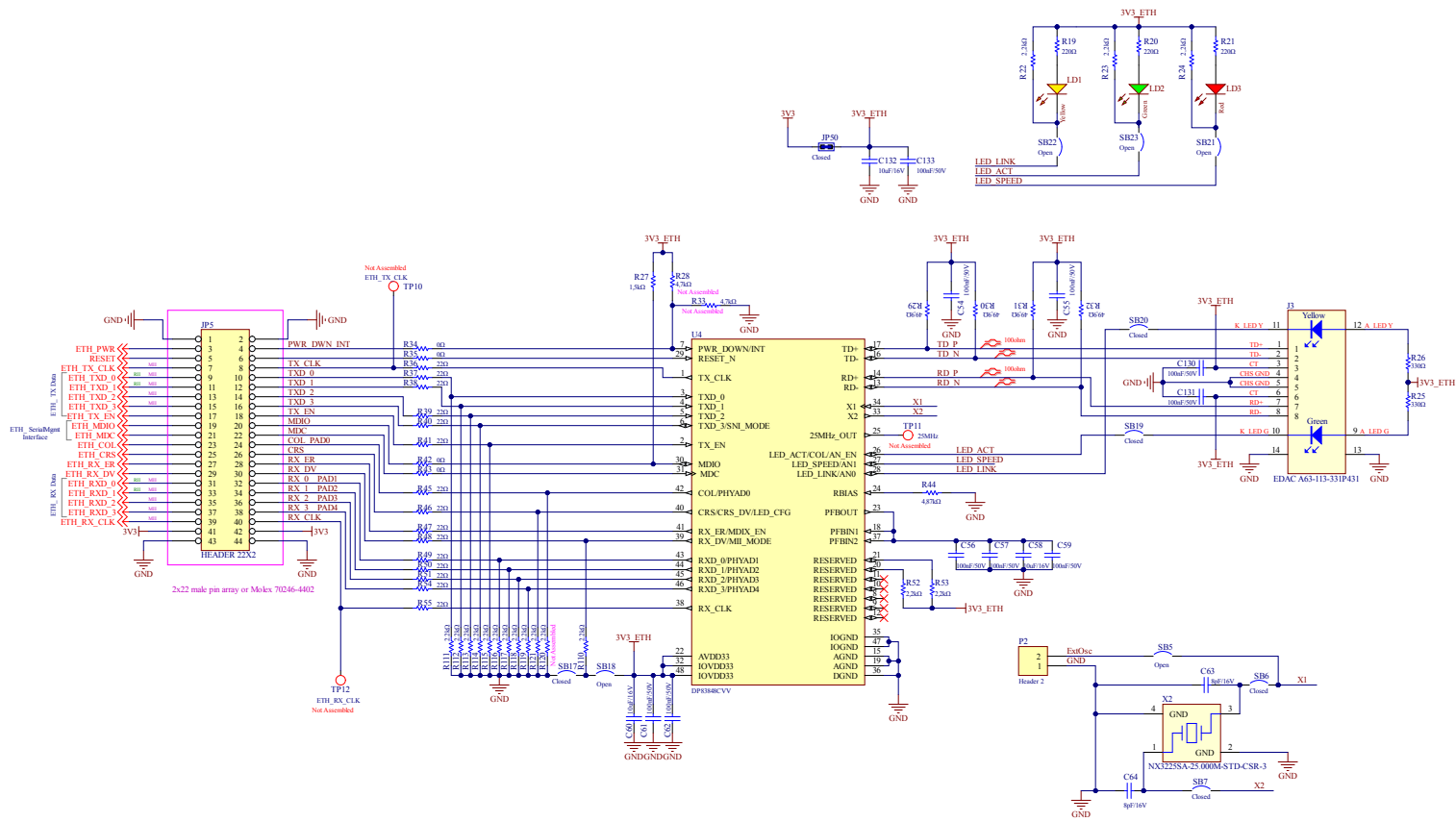


Figure 21. User interface

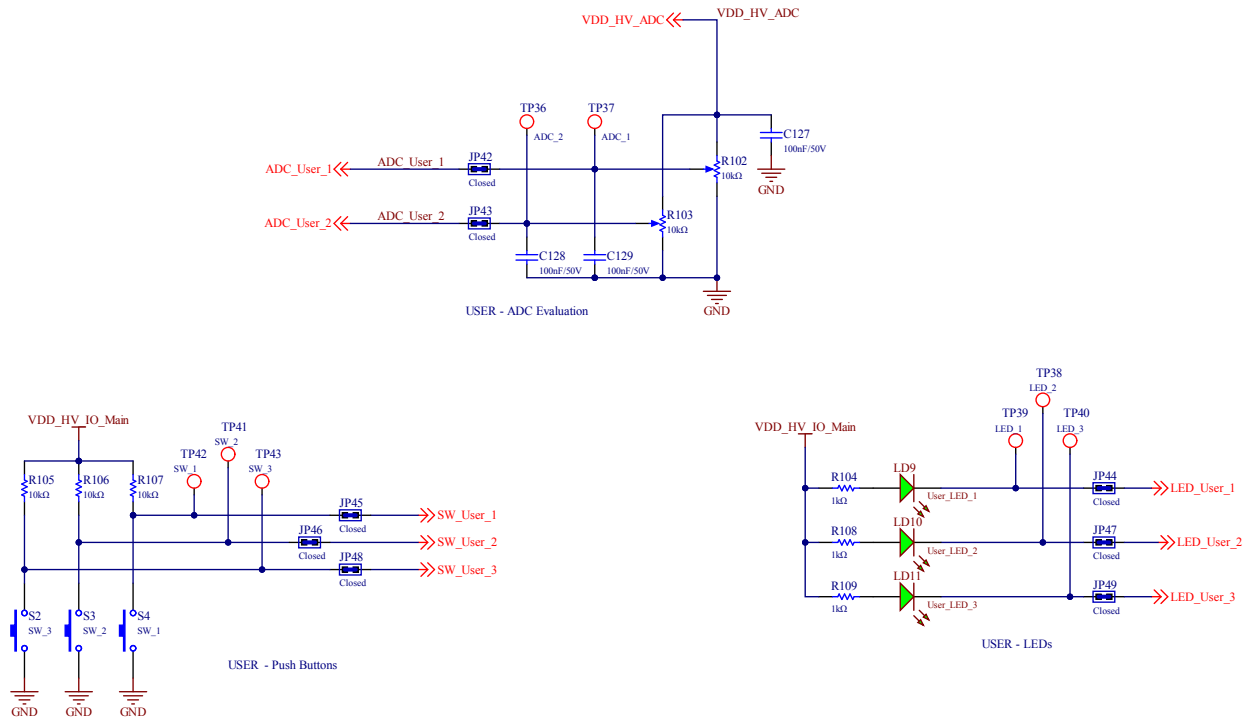
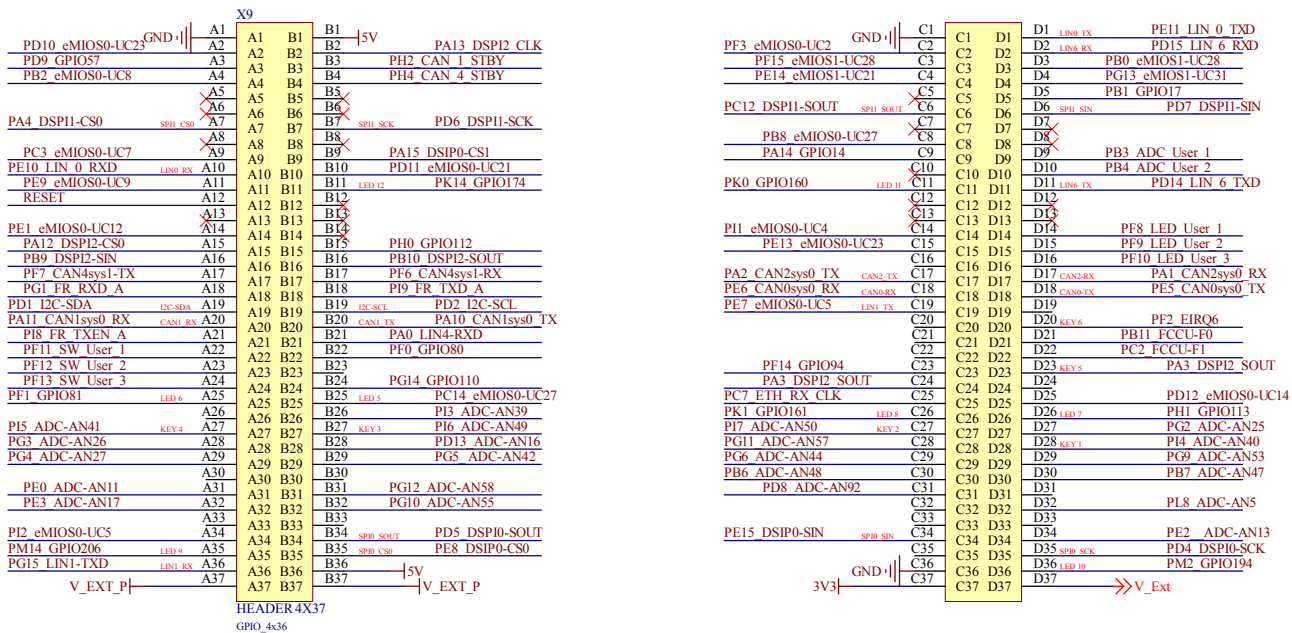


Figure 22. Extended connectors



HEADER 4X37  
GPIO\_4x36

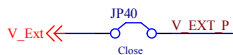


Figure 23. Microcontroller power management

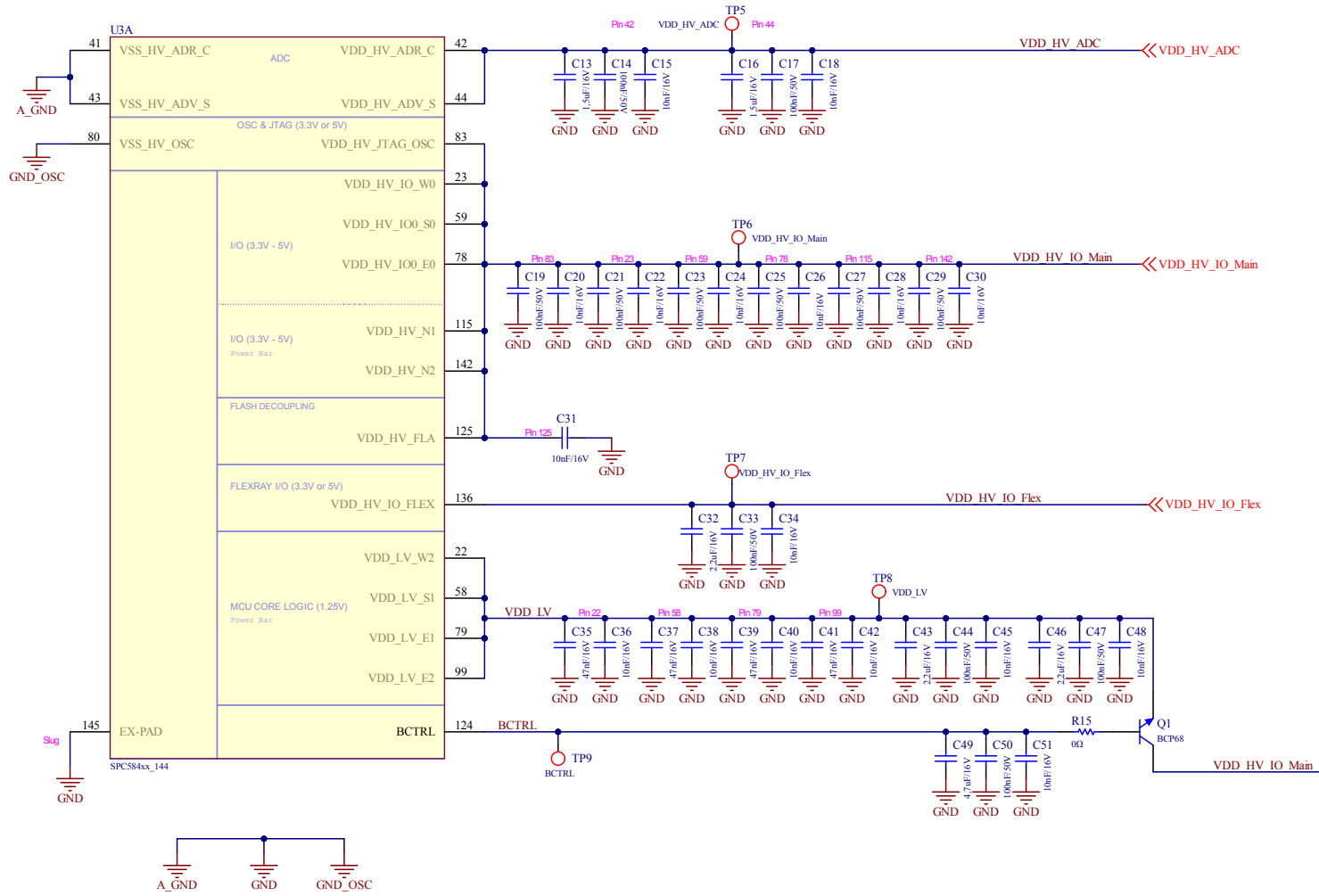
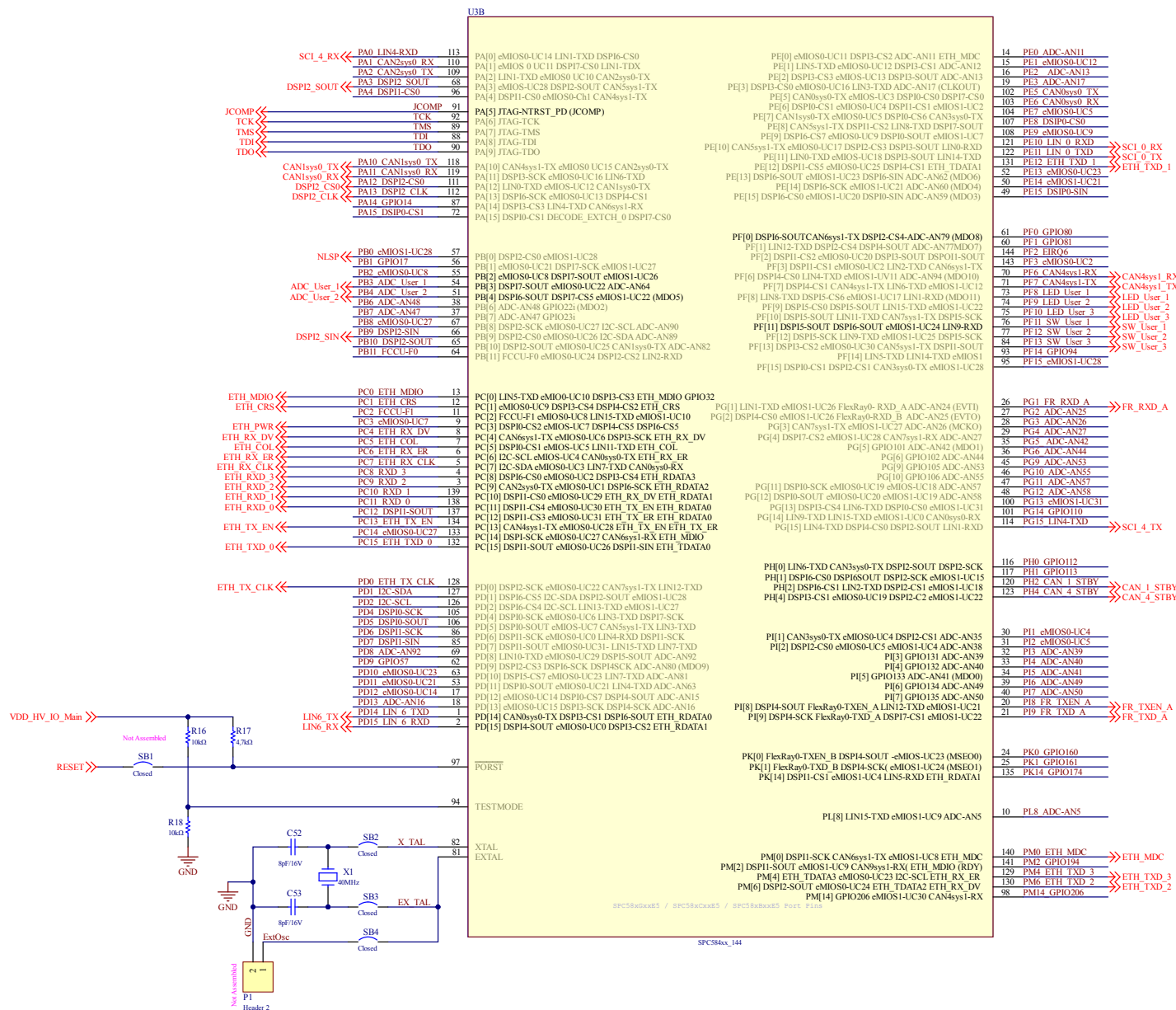


Figure 24. Microcontroller IO signal





## Revision history

**Table 3. Document revision history**

Date	Revision	Changes
25-Jul-2017	1	Initial release.
23-Mar-2022	2	Added Section 2 License agreement and Section 3 Handling precautions. Added Figure 9. RS232 section and updated Figure 10. LIN section. Updated Section 4.8 Ethernet. Updated Table 1. X9 (part I) - Extended connectors (I/O headers) and Table 2. X9 (part II) - Extended connectors (I/O headers). Replaced "Appendix A" with PCB layout chapter. Added Section 6 Schematics. Minor text changes.

## Contents

<b>1</b>	<b>Overview</b> .....	<b>2</b>
<b>2</b>	<b>License agreement</b> .....	<b>3</b>
<b>3</b>	<b>Handling precautions</b> .....	<b>4</b>
<b>4</b>	<b>Hardware overview</b> .....	<b>5</b>
4.1	Power supply section .....	5
4.2	Microcontroller power management .....	6
4.3	Integrated programmer/debugger .....	6
4.4	Crystal oscillator and reset .....	7
4.5	FlexRay .....	7
4.6	RS232 and LIN .....	8
4.7	CAN and ISO CAN-FD .....	9
4.8	Ethernet .....	9
4.9	User interface (pushbuttons, LEDs and trimmers) .....	9
4.10	Extended connectors (I/O headers) .....	10
<b>5</b>	<b>PCB layout</b> .....	<b>13</b>
<b>6</b>	<b>Schematics</b> .....	<b>14</b>
	<b>Revision history</b> .....	<b>25</b>

**IMPORTANT NOTICE – READ CAREFULLY**

STMicroelectronics NV and its subsidiaries (“ST”) reserve the right to make changes, corrections, enhancements, modifications, and improvements to ST products and/or to this document at any time without notice. Purchasers should obtain the latest relevant information on ST products before placing orders. ST products are sold pursuant to ST’s terms and conditions of sale in place at the time of order acknowledgment.

Purchasers are solely responsible for the choice, selection, and use of ST products and ST assumes no liability for application assistance or the design of purchasers’ products.

No license, express or implied, to any intellectual property right is granted by ST herein.

Resale of ST products with provisions different from the information set forth herein shall void any warranty granted by ST for such product.

ST and the ST logo are trademarks of ST. For additional information about ST trademarks, refer to [www.st.com/trademarks](http://www.st.com/trademarks). All other product or service names are the property of their respective owners.

Information in this document supersedes and replaces information previously supplied in any prior versions of this document.

© 2022 STMicroelectronics – All rights reserved