

May.1.2023 Copyright 2023 HIROSE ELECTRIC CO., LTD. All Rights Reserved.
In case of consideration for using Automotive equipment / device which demand high reliability, kindly contact our sales window correspondents.

COUNT	DESCRIPTION OF REVISIONS	BY	CHKD	DATE	COUNT	DESCRIPTION OF REVISIONS	BY	CHKD	DATE
1	DIS-H-001096	A.A	T.M	06.06.29					

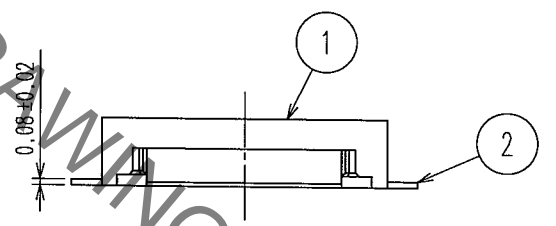

RECOMMENDED PATTERN

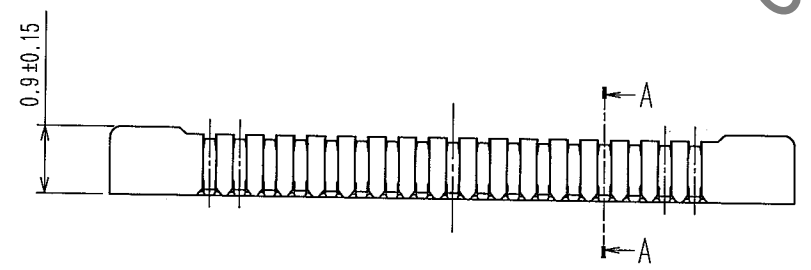
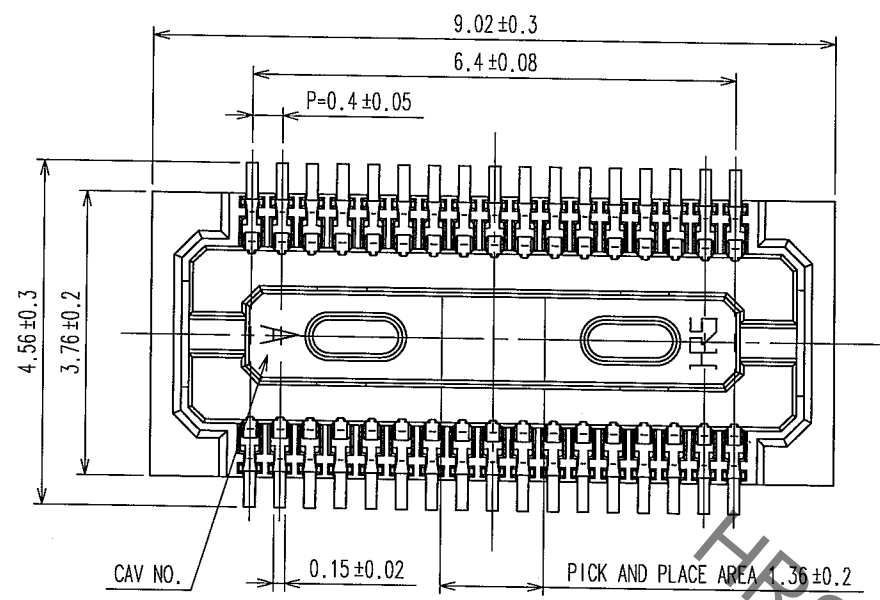
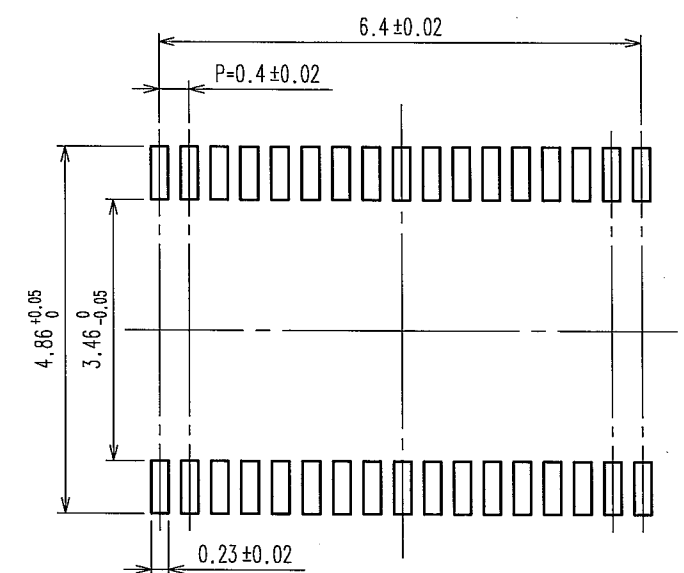

RECOMMENDED SOLDER PASTE: THICKNESS 120μ m

A-A(20:1)

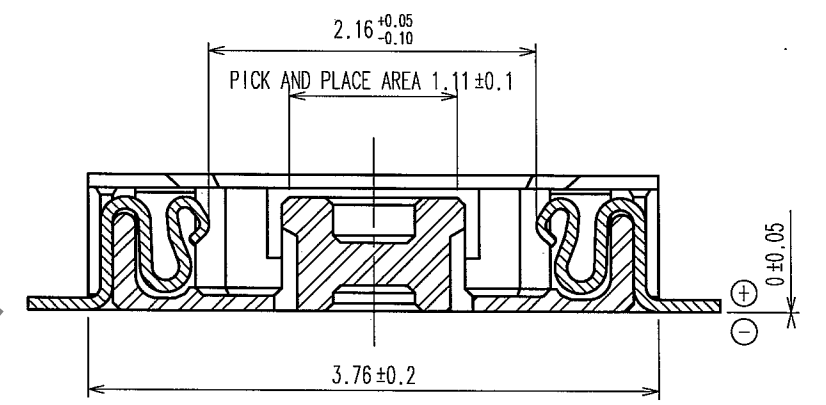

- NOTE 1. ALL LEADS CO-PLANARITY SHALL BE 0.1 MAX.
 2. PER REEL : 5000 CONNECTORS.
 3. AT THE BEGINNING OF THE REEL, 100 MM AT MIN SHALL BE EMPTY POCKETS.
 AT THE END OF THE REEL, 160 MM AT MIN SHALL BE EMPTY POCKETS.
 4. CONTACT PLATING SPECIFICATIONS.
 CONTACT AREA : GOLD 0.05μ m MIN.
 SMT LEAD : GOLD 0.02μ m MIN.
 UNDERPLATING : NICKEL 1μ m MIN.
 (SURFACE : SEALING)

2	PHOSPHOR BRONZE	4	5	PS	PLASTIC REEL (BLACK)
1	LCP	UL94V-0, BLACK	4	POLYESTER	CLEAR (COVER TAPE)
			3	PS	CLEAR (EMBOSSED CARRIER TAPE)
NO.	MATERIAL	FINISH, REMARKS	NO.	MATERIAL	FINISH, REMARKS
CODE NO. (OLD)		DRAWN	DESIGNED	CHECKED	APPROVED
		F. MATSUKI	A. TAKAHASHI	T. SAKATA	T. SAKATA
		'05.01.27	'05.01.28	'05.01.31	'05.01.31
DRAWING NO.		PART NO.			
EDC3-303465-04		DF30FC-34DS-0.4V(81)			
SCALE		CODE NO.			
10 : 1		CL684-1113-5-81		1/2	
UNITS		HIROSE ELECTRIC CO., LTD			
mm					

May.1.2023 Copyright 2023 HIROSE ELECTRIC CO., LTD. All Rights Reserved.
In case of consideration for using Automotive equipment / device which demand high reliability, kindly contact our sales window correspondents.

5		6			7			8		
COUNT	DESCRIPTION OF REVISIONS	BY	CHKD	DATE	COUNT	DESCRIPTION OF REVISIONS	BY	CHKD	DATE	
△					△					
△					△					
△					△					

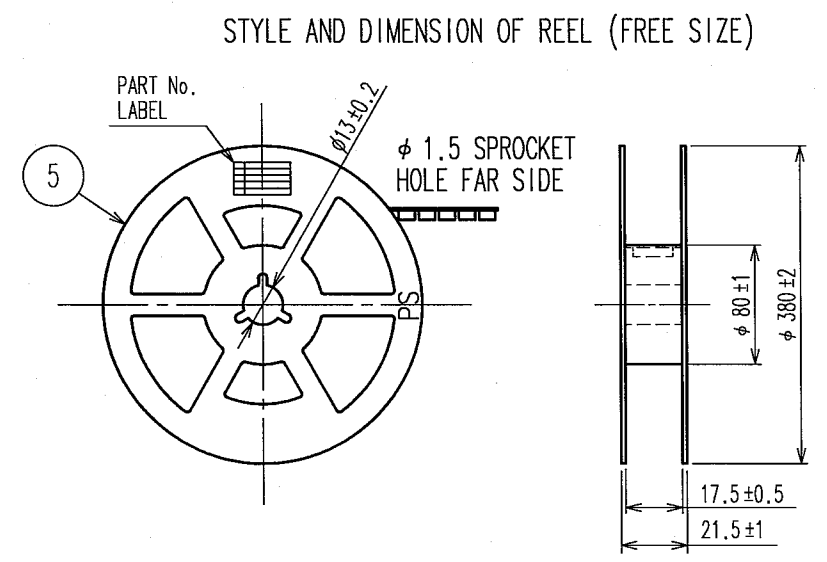
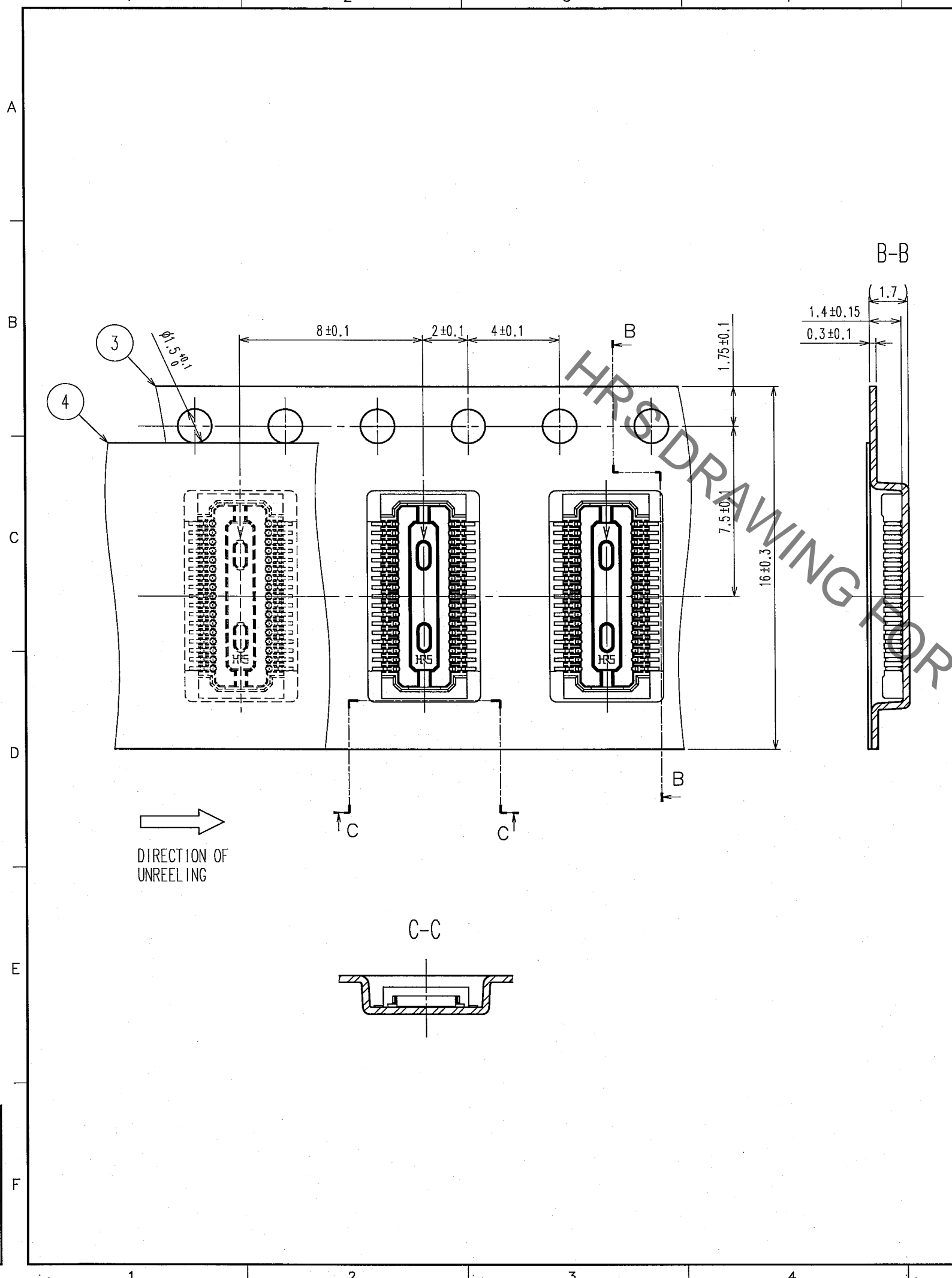

DETAIL OF PART NO. LABEL

SUPPLIER	HIROSE ELECTRIC CO., LTD.
QUANTITY	5000個
PART NO.	DF30FC-34DS-0.4V(81)
CODE NO.	CL684-1113-5-81
DATE OF MANUFACTURED	生産月日 年 月 日
	図番 CL684-1113-5-81
	品名 DF30FC-34DS-0.4V(81)
	納入数量 5000個
	納入者 ヒロセ電機(株)

CODE NO. (OLD)	DRAWN	DESIGNED	CHECKED	APPROVED	RELEASED
	F. MATSUKI	A. TAKAHASHI	T. SAKATA	T. SAKATA	
	'05.01.27	'05.01.28	'05.01.31	'05.01.31	
SCALE	DRAWING NO.		PART NO.		
5 : 1	EDC3-303465-04		DF30FC-34DS-0.4V(81)		
UNITS	HRS HIROSE ELECTRIC CO., LTD		CODE NO.		2
mm			CL684-1113-5-81		