

REVISIONS			
REV	DESCRIPTION	DATE	APPV
A	PRODUCTION RELEASE	JHAGER 3/29/21	

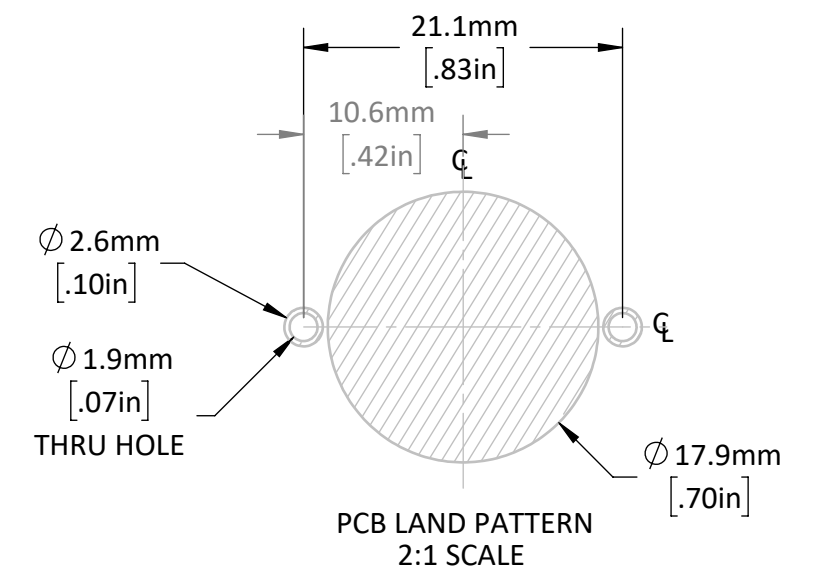

- NOTES: (UNLESS OTHERWISE SPECIFIED)
1. ALL DIMENSIONS ARE IN MILLIMETERS [IN].
 2. DIMENSIONS APPLY AFTER FINISHING.
 3. MANUFACTURE TO BE COMPLIANT WITH EU RoHS DIRECTIVE, USE MATERIALS THAT DO NOT CONTAIN REACH SUBSTANCES OF VERY HIGH CONCERN >1000ppm, AND USE DRC CONFLICT-FREE SOURCED MATERIALS.
 4. ALL UNLISTED GEOMETRY CONTROLLED BY MODEL AT LATEST REVISION.
 5. MATERIAL: .250mm C5191 PHOSPHOR BRONZE 3µIN NICKEL PLATING.
 6. BEND RADIUS: MINIMUM FOR LISTED MATERIAL AT TEMPER LEVEL SHOWN. ALL BENDS 90° UNLESS OTHERWISE SPECIFIED.
 7. INTENDED TO ACCOMODATE CR2032 FORM FACTOR Ø20mm POWER CELL.

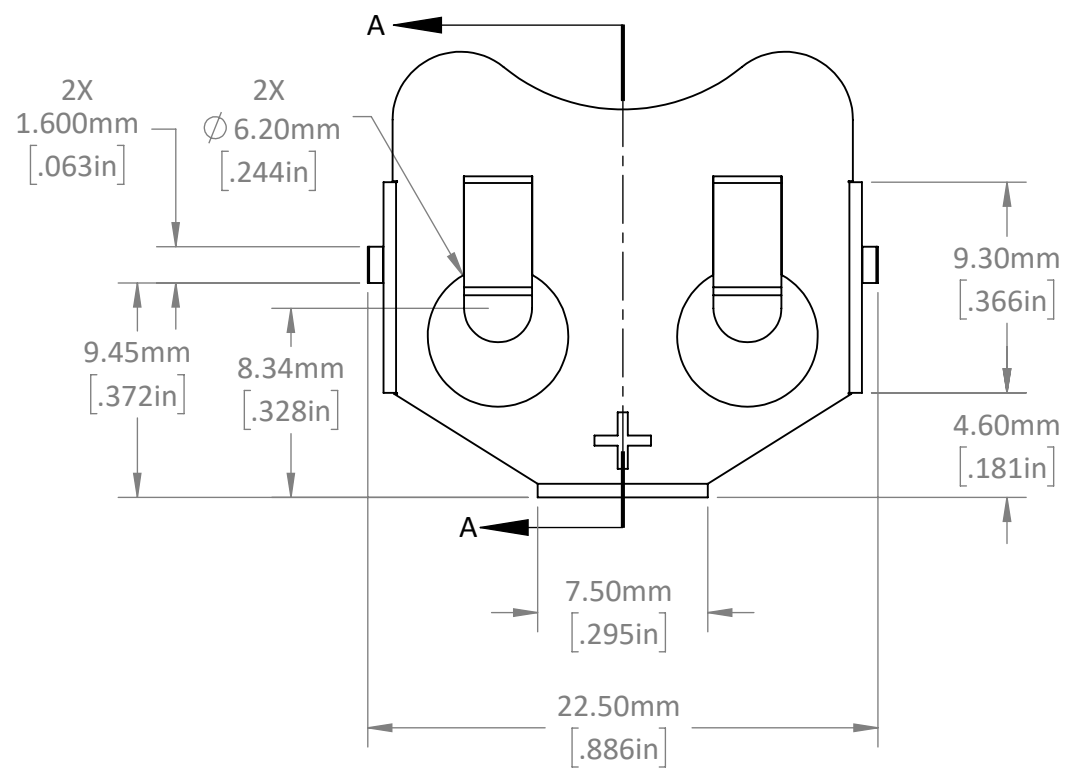
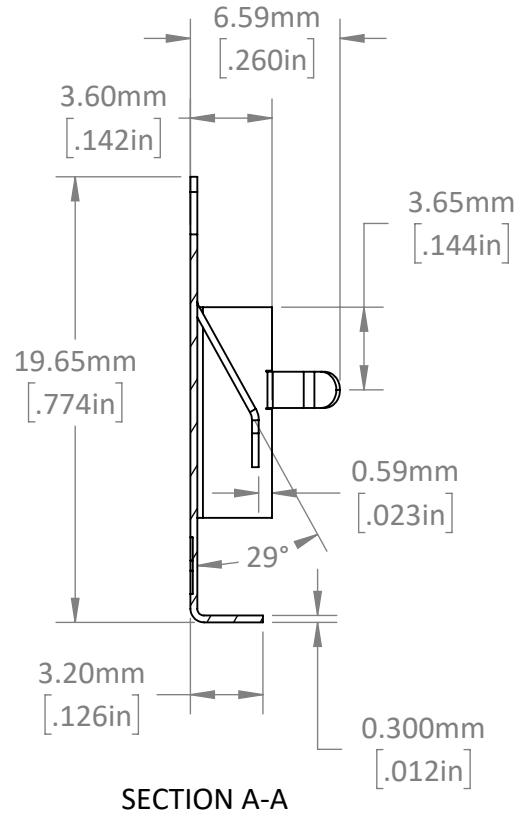
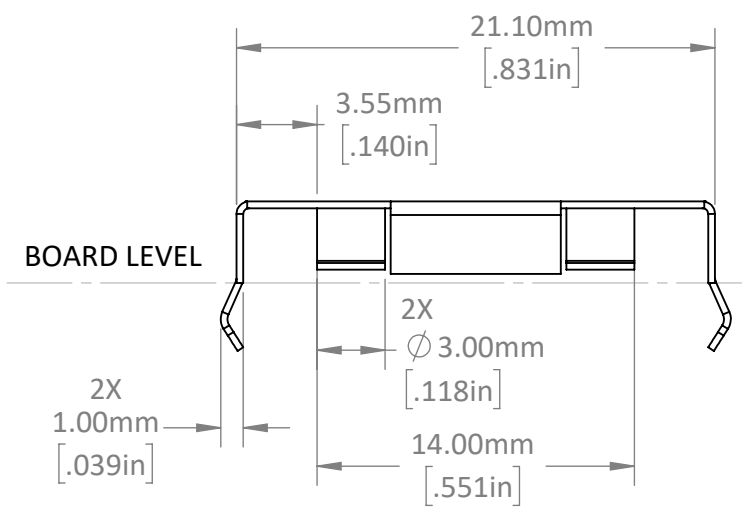

WARNING: THIS DRAWING CONTAINS PROPRIETARY INFORMATION THAT IS THE SOLE PROPERTY OF LINX TECHNOLOGIES, AND SHALL BE TREATED AS SUCH. NO DISCLOSURE OR REPRODUCTION OF THIS DOCUMENT IS PERMITTED, IN WHOLE OR IN PART, WITHOUT THE EXPRESS WRITTEN PERMISSION OF LINX TECHNOLOGIES OR ITS DESIGNATED AGENTS.

MATERIAL: PHOSPHOR BRONZE C5191	INTERPRET DIMENSIONS AND TOLERANCES PER ASME Y14.5. .X ±.3 .XX ±.20 .XXX ±.100	PROJECTION:
WEIGHT: 1.04gm	ANGLES: ±1° SURFACE:	
FINISH: NICKEL	DRAWN: JHAGER ENGR: SHOGAN	DT: 3/29/21 DT: 3/29/21

Linx 159 ORT LANE
MERLIN, OR 97532

TITLE:
**Battery Retainer Coin, 20.0mm
1 Cell THM, 2016, 2020, 2025, 2032**

SIZE B	DWG. NO. BAT-HLD-005-THM	REV A
------------------	-----------------------------	-----------------

SCALE: 3:1 DO NOT SCALE DRAWING SHEET 1 OF 1