

May.1.2023 Copyright 2023 HIROSE ELECTRIC CO., LTD. All Rights Reserved.
In case of consideration for using Automotive equipment / device which demand high reliability, kindly contact our sales window correspondents.

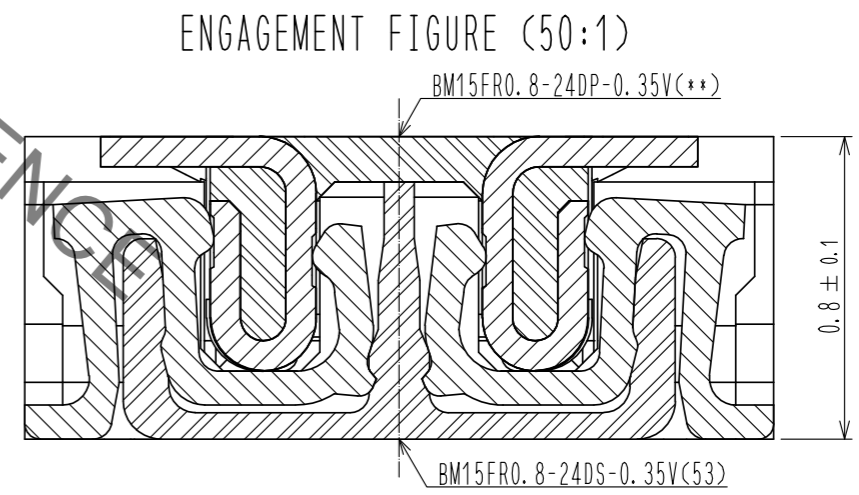
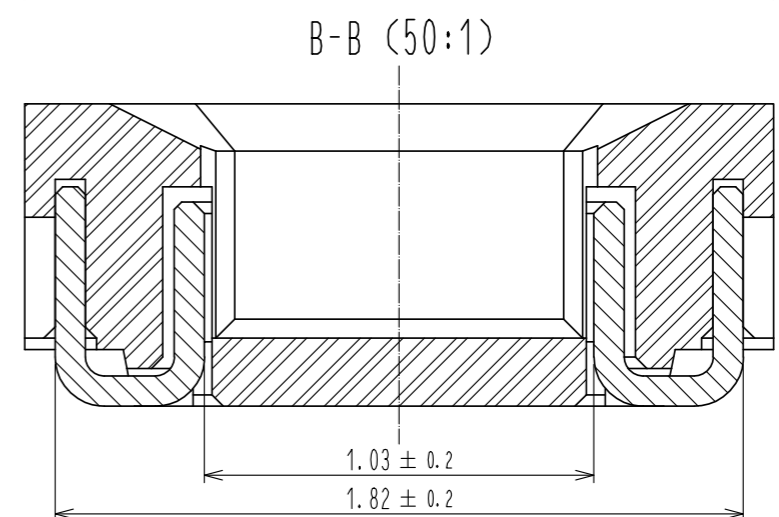
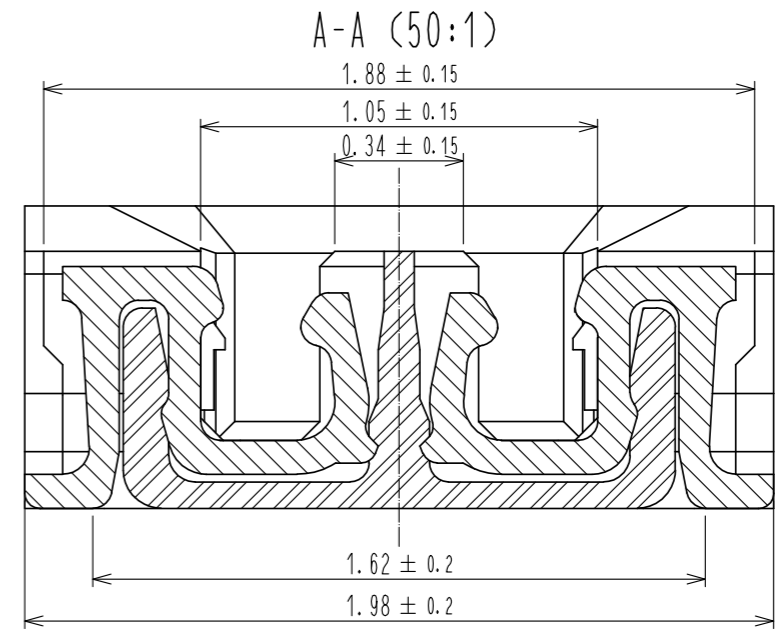
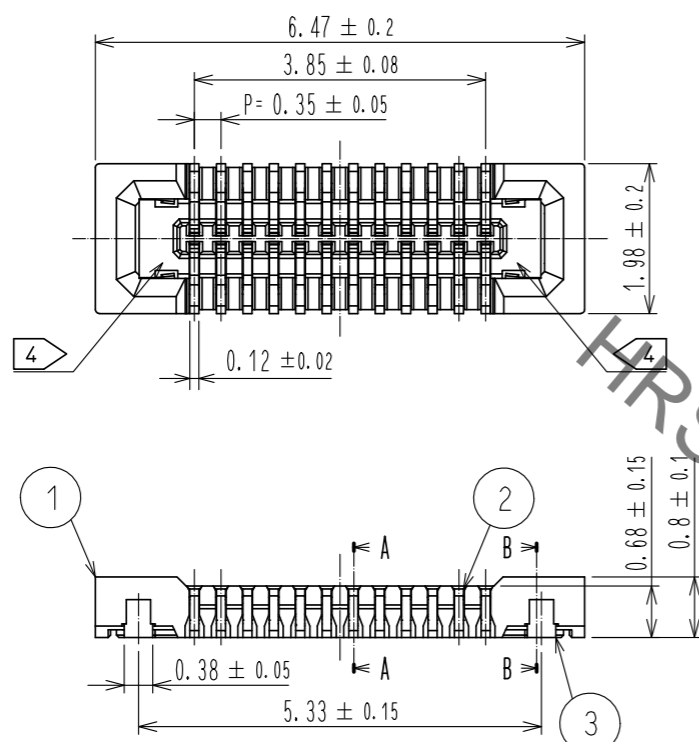

NOTE) 1 . ALL LEAD CO-PLANARITY SHALL BE 0.08mm MAX
 2 CONTACT PLATING SPECIFICATIONS.
 CONTACT AREA : GOLD 0.05 μm MIN
 SMT LEAD : GOLD 0.05 μm MIN
 UNDERPLATING : NICKEL 1 μm MIN
 (SURFACE : SEALING)
 3 REINFORCED METAL FITTINGS LOCK
 SMT LEAD : GOLD 0.05 μm MIN
 UNDERPLATING : NICKEL 1 μm MIN
 (SURFACE : SEALING)
 4 CAV NO. AND HRS MARK MAY BE INDICATED IN APPROX POSITION SHOWN.

4	PS	CLEAR (ENBOSSED CARRIER TAPE)						
3	PHOSPHOR BRONZE	3	7	PS	CLEAR (REINFORCEMENT COLLAR)			
2	PHOSPHOR BRONZE	2	6	PS	BLACK (PLASTIC REEL)			
1	LCP	UL94 V-0, BLACK	5	POLYESTER	CLEAR (COVER TAPE)			
NO.	MATERIAL	FINISH . REMARKS	NO.	MATERIAL	FINISH . REMARKS			
UNITS	mm	SCALE	10 : 1	COUNT	DESCRIPTION OF REVISIONS	DESIGNED	CHECKED	DATE
HRS HIROSE ELECTRIC CO., LTD.		APPROVED : MO. ISHIDA	16.01.08	DRAWING NO. EDC-355889-53-01				
		CHECKED : TS. MIYAZAKI	16.01.08	PART NO. BM15FR0.8-24DS-0.35V(53)				
		DESIGNED : SH. HOSODA	16.01.07	CODE NO. CL673-1229-6-53				
		DRAWN : KR. AJITO	16.01.07					

May.1.2023 Copyright 2023 HIROSE ELECTRIC CO., LTD. All Rights Reserved.
In case of consideration for using Automotive equipment / device which demand high reliability, kindly contact our sales window correspondents.

◆ RECOMMENDED PCB LAYOUT

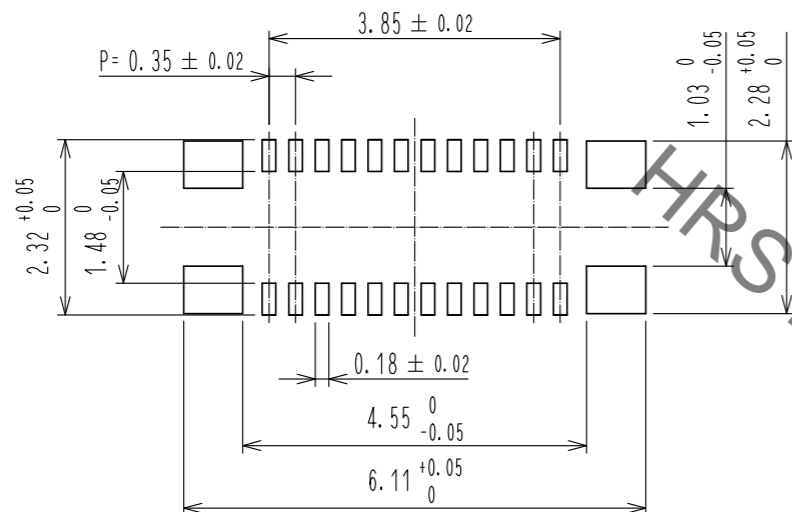

◆ RECOMMENDED METAL MASK DIMENSIONS

METAL MASK THICKNESS : 100 μm

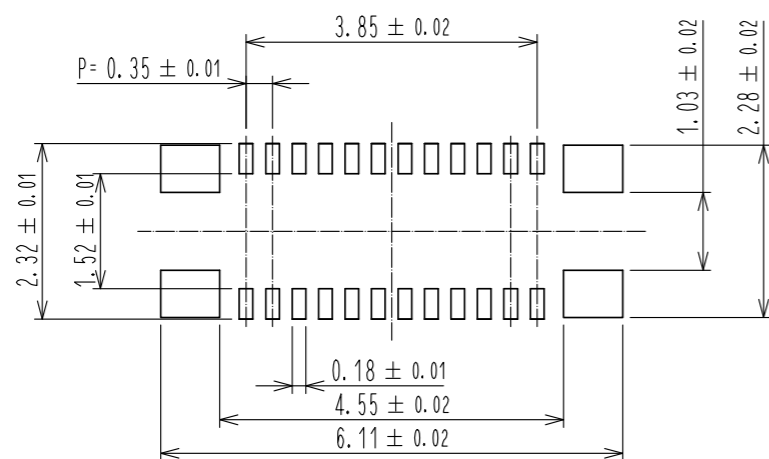

⇒ RECOMMENDED REFLOW TEMPERATURE PROFILE USING LEAD-FREE SOLDER PASTE.

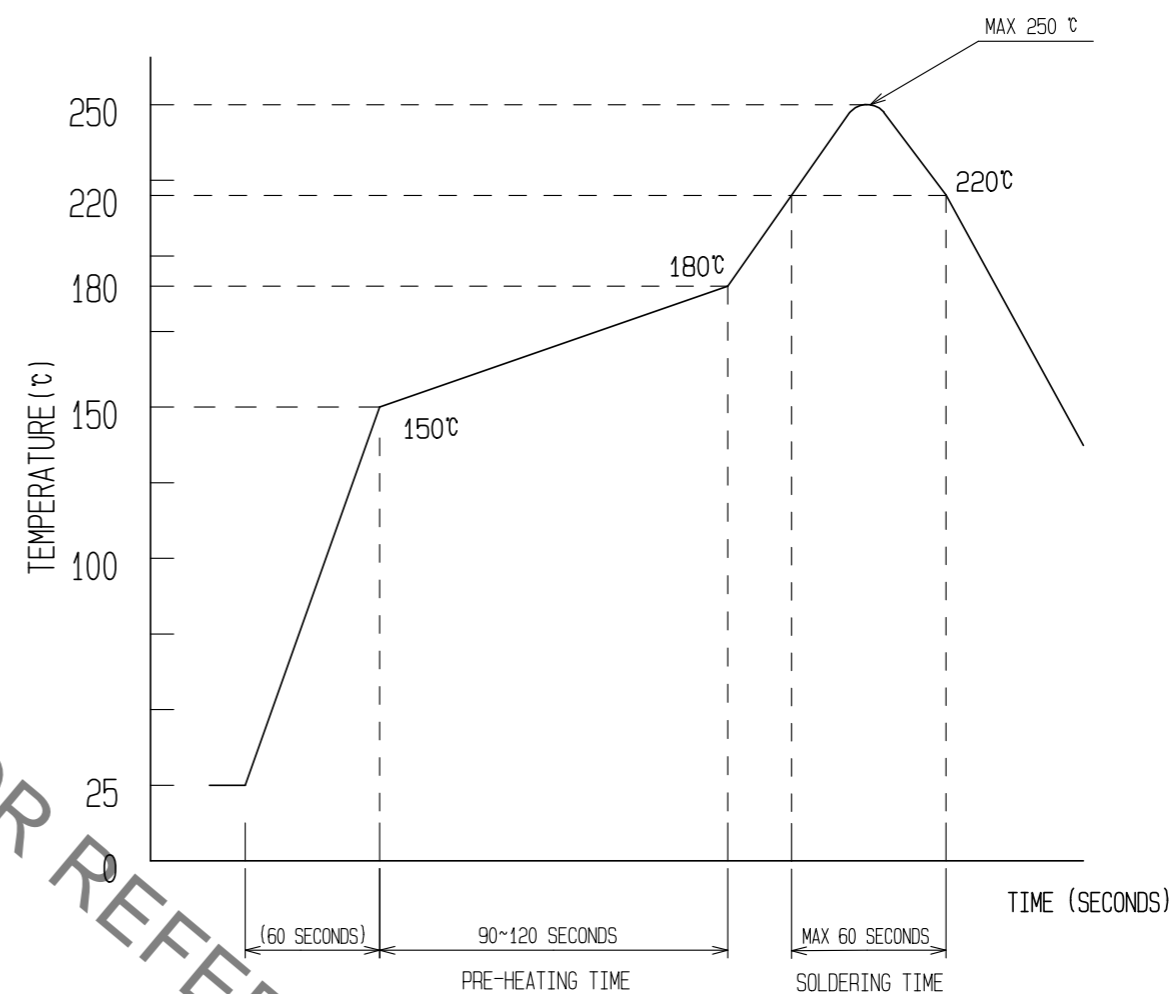

- REFLOW METHOD: IR REFLOW
 NUMBER OF REFLOW CYCLES: 2 CYCLES MAX.
 1) REFLOW TIME
 DURATION ABOVE 220°C: 60 SEC. MAX.
 (PEAK TEMPERATURE: 250°C MAX)
 2) PRE-HEAT TIME
 PRE-HEAT TEMPERATURE(MIN): 150°C
 PRE-HEAT TEMPERATURE(MAX): 180°C
 PRE-HEAT TIME: 90-120 sec.

⇒ THIS TEMPERATURE PROFILE IS PER THE CONDITIONS SHOWN ABOVE. ADDITIONAL FACTORS, SUCH AS SOLDER PASTE TYPE, PCB SIZE AND OTHER MOUNTED COMPONENTS COULD AFFECT THE PROFILE, THEREFORE, A THOROUGH EVALUATION OF MOUNTING CONDITION IS REQUIRED PRIOR TO PRODUCTION. TEMPERATURE IS MEASURED AT CONTACT LEAD.

HRS	DRAWING NO.	EDC-355889-53-01
	PART NO.	BM15FR0.8-24DS-0.35V(53)
	CODE NO.	CL673-1229-6-53

May.1.2023 Copyright 2023 HIROSE ELECTRIC CO., LTD. All Rights Reserved.
In case of consideration for using Automotive equipment / device which demand high reliability, kindly contact our sales window correspondents.

EMBOSED CARRIER TAPE PACKAGING (5:1)

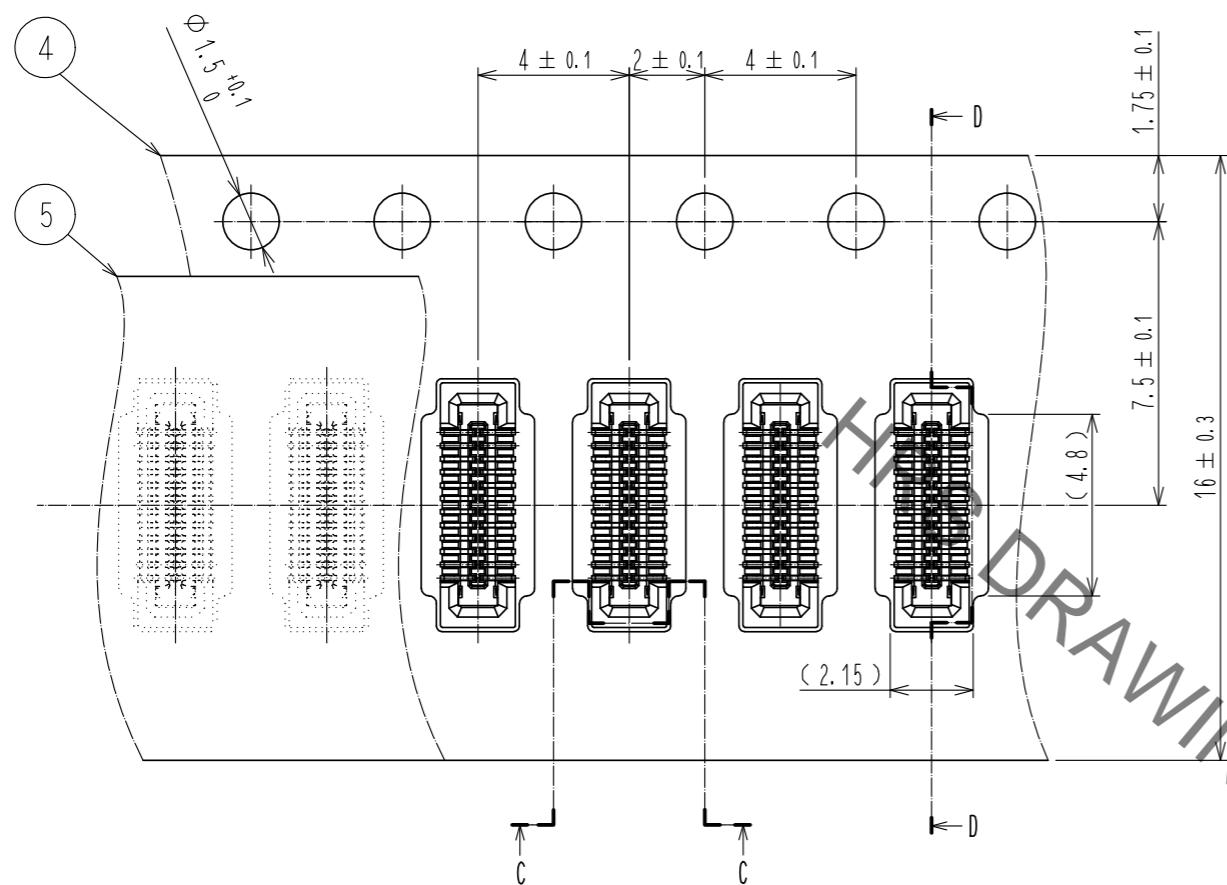

DIRECTION OF UNREELING
→

C-C (5:1)

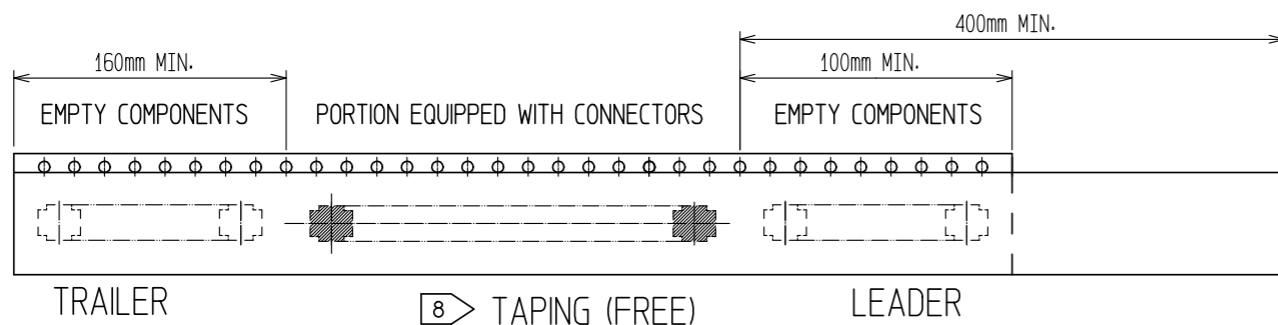
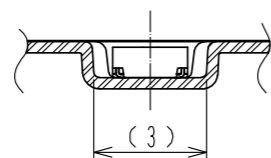

D-D (5:1)

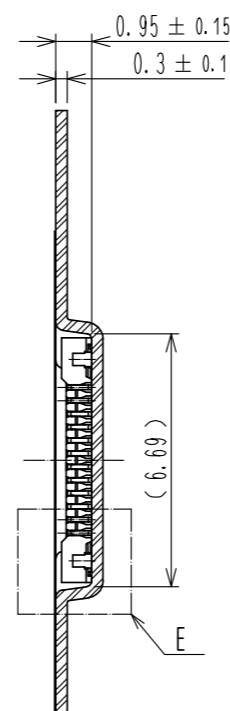

STYLE AND DIMENTION OF REEL (FREE)

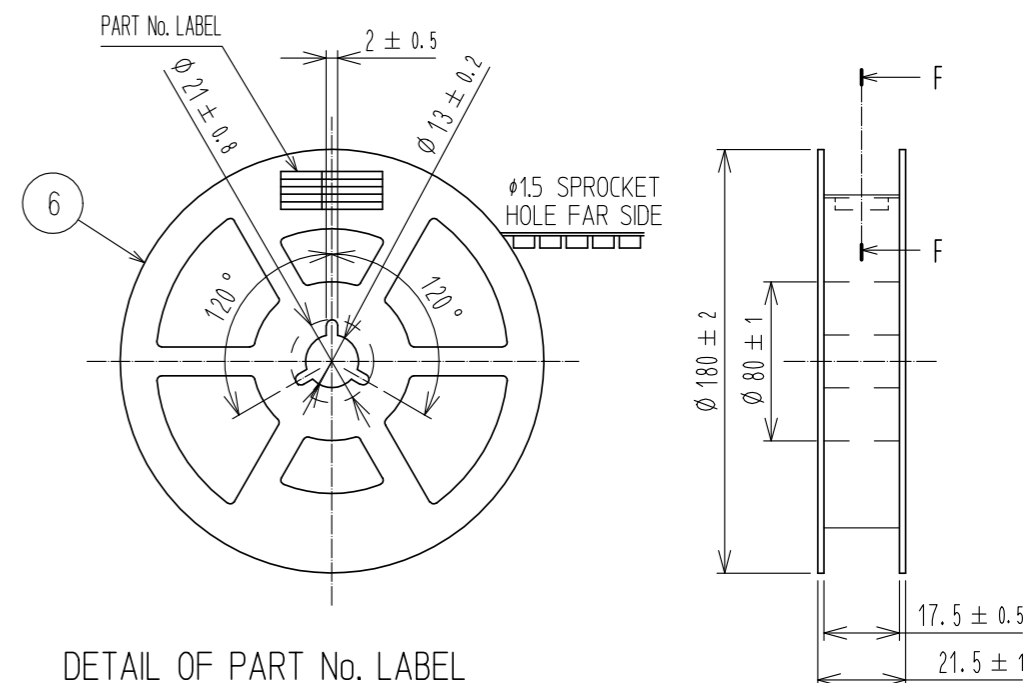

DETAIL OF PART No. LABEL

SUPPLIER	
QUANTITY	
PART No.	
CODE No.	
DATE OF MANUFACTURED	
製造年月日	** ** *
製品コード	CL673-1229-6-53
製品名	BM15FR0.8-24DS-0.35V(53)
数量	1,000
納入者	ヒロセ電機(株)

F-F (FREE)

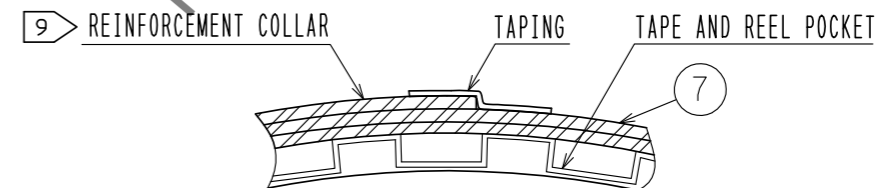

E(10:1)

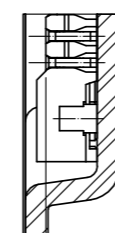

- 6. PER REEL 1000 CONNECTORS.
- 7. THE DIMENSIONS IN PARENTHESES ARE FOR REFERENCE.
- 8. REFER TO JIS C 0806 AND IEC 60286-3 (PACKAGING OF COMPONENTS FOR AUTOMATIC HANDLING)
- 9. AFTER PACKAGING, ROLL 2 METERS OF THE REINFORCEMENT COLLAR TO OUTER CIRCUMFERENCE OF TAPE AND REEL POCKET, AND TAPE DOWN AT THE END THE COLLAR.

HRS	DRAWING NO.	EDC-355889-53-01
	PART NO.	BM15FR0.8-24DS-0.35V(53)
	CODE NO.	CL673-1229-6-53
		3/3