

May.1.2023 Copyright 2023 HIROSE ELECTRIC CO., LTD. All Rights Reserved.  
In case of consideration for using Automotive equipment / device which demand high reliability, kindly contact our sales window correspondents.

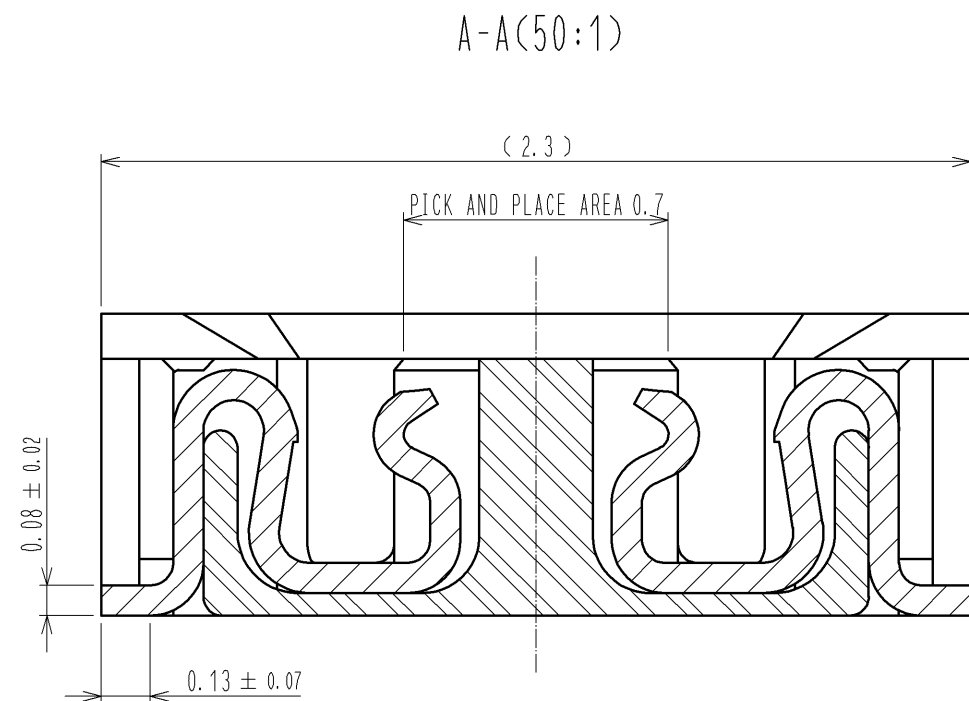

ENGAGEMENT FIGURE (50:1)

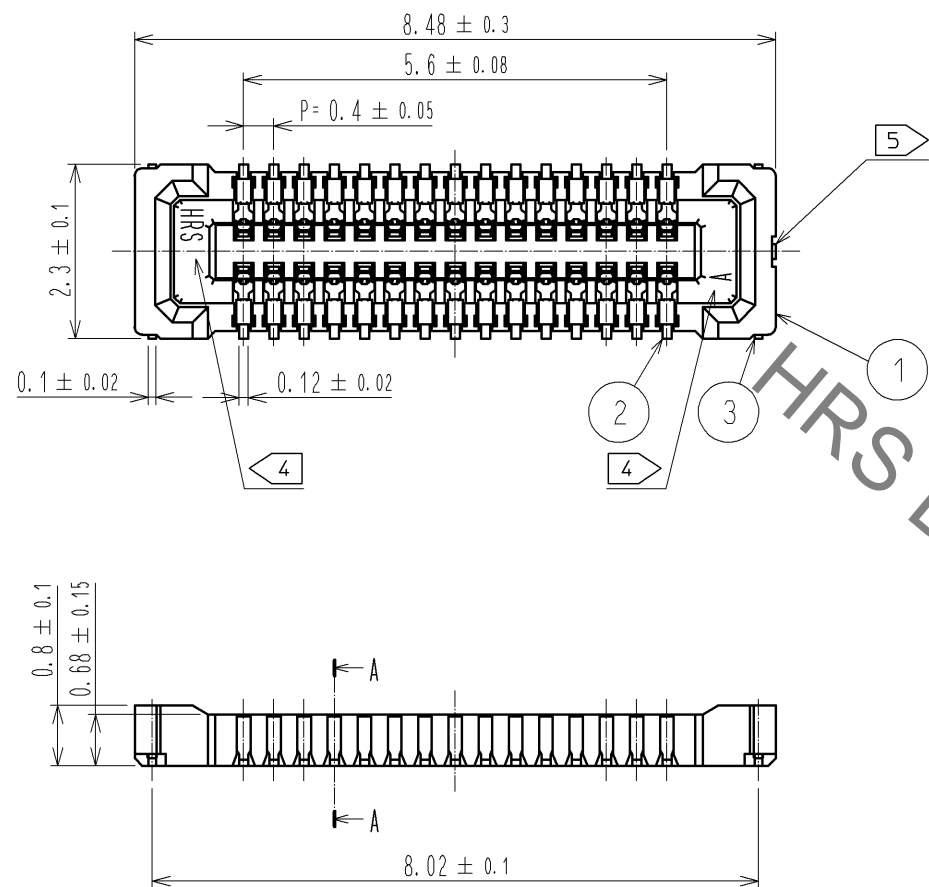
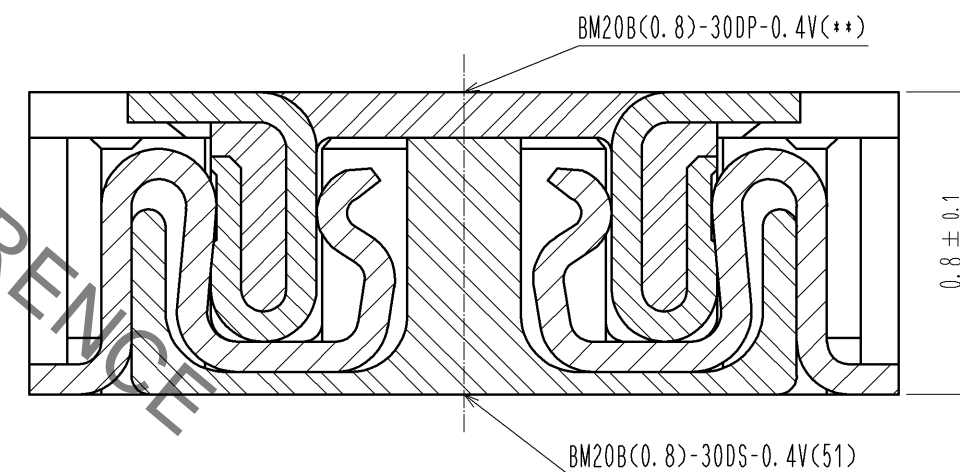

- NOTE 1 . ALL LEAD CO-PLANARITY SHALL BE 0.08mm MAX
- 2 CONTACT PLATING SPECIFICATIONS  
CONTACT AREA : GOLD 0.05 μm MIN  
SMT LEAD : GOLD 0.05 μm MIN  
UNDERPLATING : NICKEL 1 μm MIN  
( SURFACE : SEALING )
- 3 METAL FITTING PLATING SPECIFICATIONS  
SMT LEAD : GOLD 0.05 μm MIN  
UNDERPLATING : NICKEL 1 μm MIN  
( SURFACE : SEALING )
- 4 HRS MARK AND CAV NO. ARE INDICATED IN APPROX POSITION SHOWN.
- 5 GATE POSITION IS INDICATED IN APPROX POSITION SHOWN.

4	PS	CLEAR (EMBOSSED CARRIER TAPE)						
3	BRASS	3	7	PS	CLEAR (REINFORCEMENT COLLAR)			
2	PHOSPHOR BRONZE	2	6	PS	BLACK (PLASTIC REEL)			
1	LCP	UL94 V-0, BLACK	5	POLYESTER	CLEAR (COVER TAPE)			
NO.	MATERIAL	FINISH . REMARKS	NO.	MATERIAL	FINISH . REMARKS			
UNITS	mm	SCALE	10 : 1	COUNT	DESCRIPTION OF REVISIONS	DESIGNED	CHECKED	DATE
HRS		HIROSE ELECTRIC CO., LTD.	APPROVED : KH. IKEDA	12.03.15	DRAWING NO.	EDC3-332317-01		
			CHECKED : TS. MIYAZAKI	12.03.15	PART NO.	BM20B(0.8)-30DS-0.4V(51)		
			DESIGNED : YK. SATAKE	12.03.14	CODE NO.	CL684-9011-9-51		
			DRAWN : KR. AJITO	12.03.14		1/3		

May.1.2023 Copyright 2023 HIROSE ELECTRIC CO., LTD. All Rights Reserved.  
In case of consideration for using Automotive equipment / device which demand high reliability, kindly contact our sales window correspondents.

◆ RECOMMENDED PCB LAYOUT

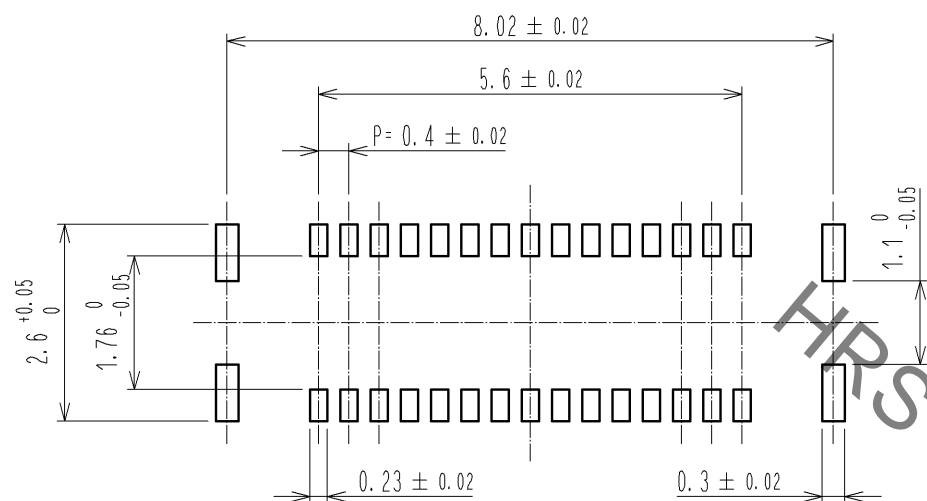

◆ RECOMMENDED METAL MASK DIMENSIONS

MATAL MASK THICKNESS : 100 μm

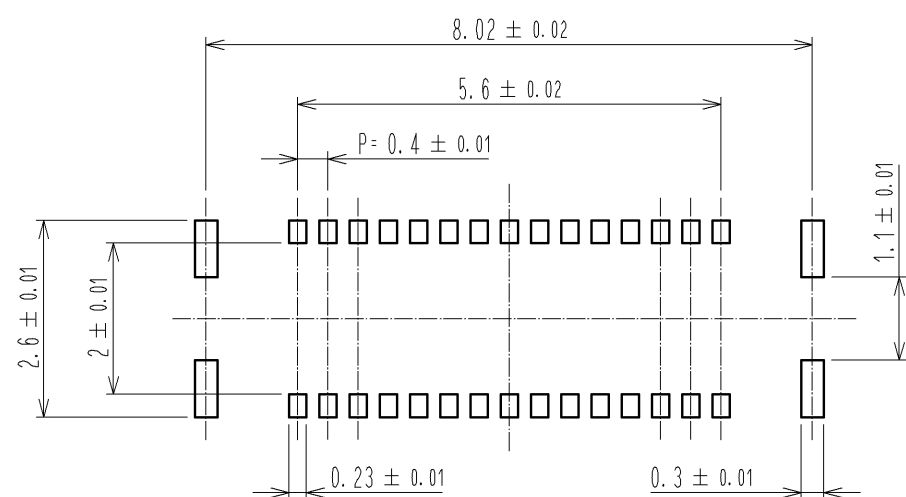

6 RECOMMENDED REFLOW TEMPERATURE PROFILE USING LEAD-FREE SOLDER PASTE.

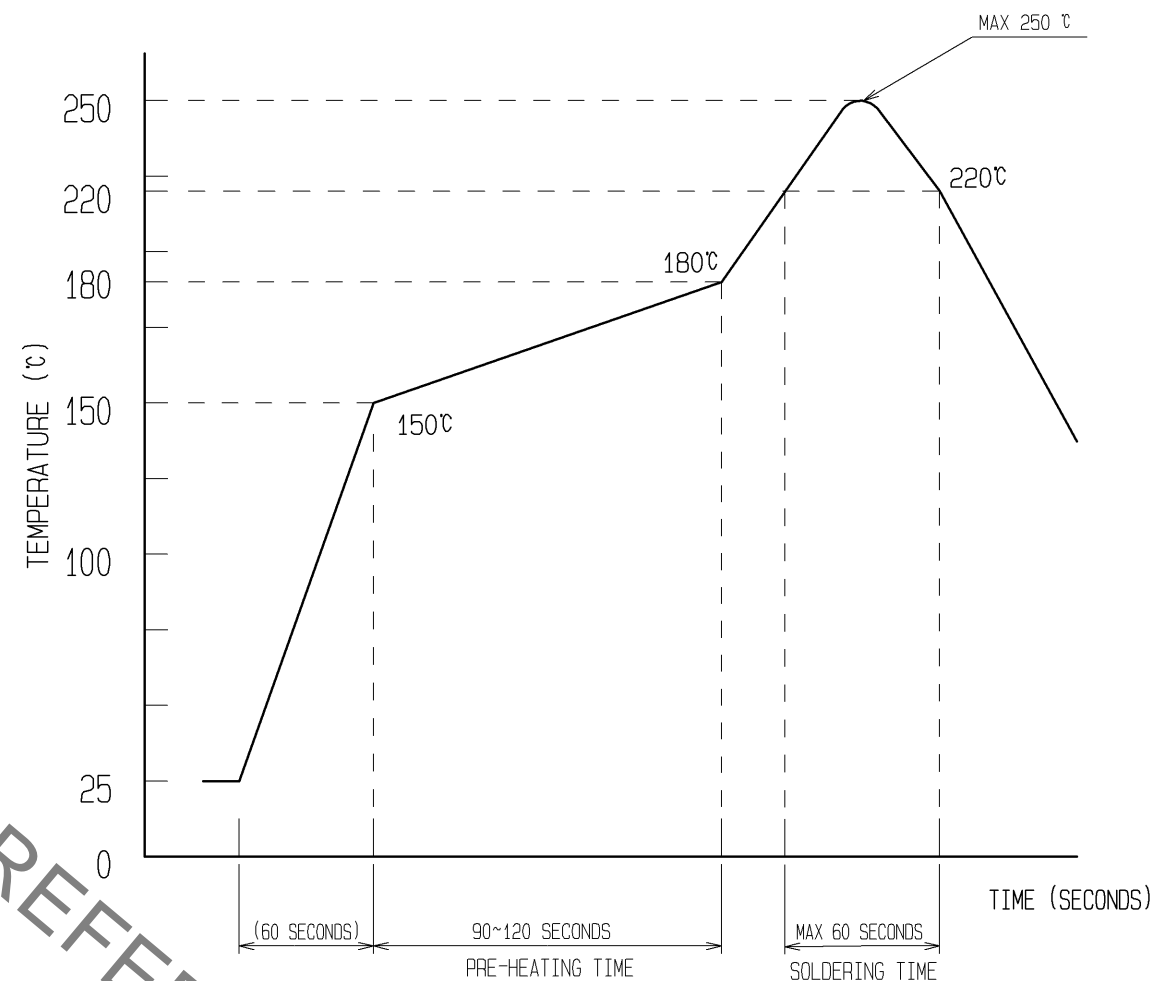

REFLOW METHOD : IR REFLOW  
 NUMBER OF REFLOW CYCLES : 2 CYCLES MAX.  
 1) REFLOW TIME  
 DURATION ABOVE 220°C, 60 SEC MAX.  
 (PEAK TEMPERATURE : 250°C MAX)  
 2) PRE-HEAT TIME  
 PRE-HEAT TEMPERATURE(MIN): 150°C  
 PRE-HEAT TEMPERATURE(MAX): 180°C  
 PRE-HEAT TIME: 90-120 SEC.

6 THE TEMPERATURE PROFILE IS PER THE CONDITIONS SHOWN ABOVE.  
 ADDITIONAL FACTORS, SUCH AS SOLDER PASTE TYPE, PCB SIZE AND  
 OTHER MOUNTED COMPONENTS COULD AFFECT THE PROFILE. THEREFORE,  
 A THOROUGH EVALUATION OF MOUNTING CONDITION IS REQUIRED  
 PRIOR TO PRODUCTION. TEMPERATURE IS MEASURED AT CONTACT LEAD.

<b>HRS</b>	DRAWING NO.	EDC3-332317-01
	PART NO.	BM20B(0.8)-30DS-0.4V(51)
	CODE NO.	CL684-9011-9-51

May.1.2023 Copyright 2023 HIROSE ELECTRIC CO., LTD. All Rights Reserved.  
In case of consideration for using Automotive equipment / device which demand high reliability, kindly contact our sales window correspondents.

### EMBOSSED CARRIER TAPE PACKAGING (5:1)

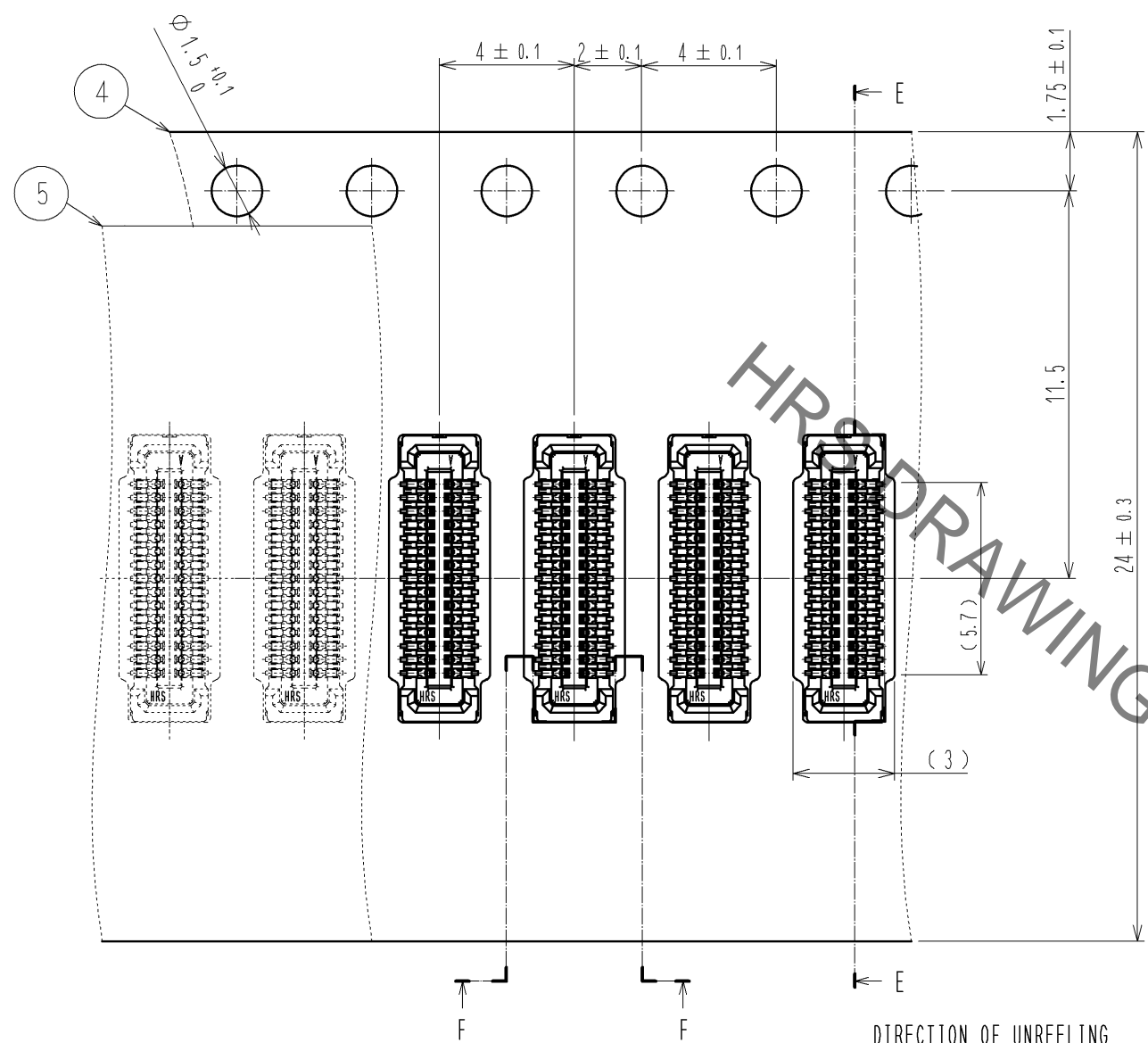

DIRECTION OF UNREELING  $\rightarrow$

#### F-F (5:1)

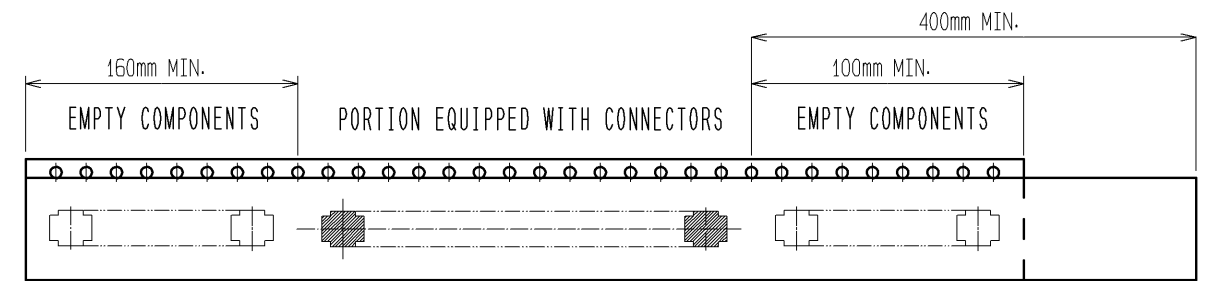
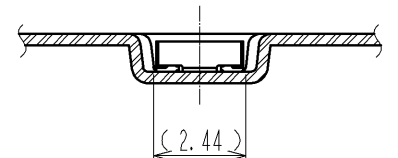

9 TAPING (FREE)

#### E-E (5:1)

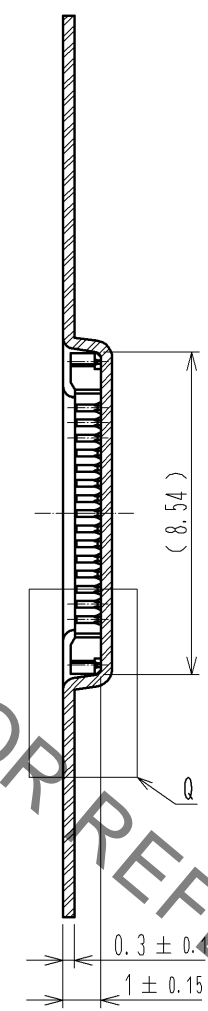

#### Q(10:1)

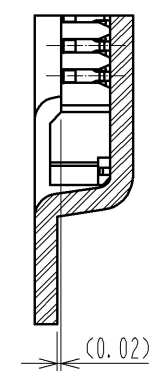

### STYLE AND DIMENTION OF REEL (FREE)

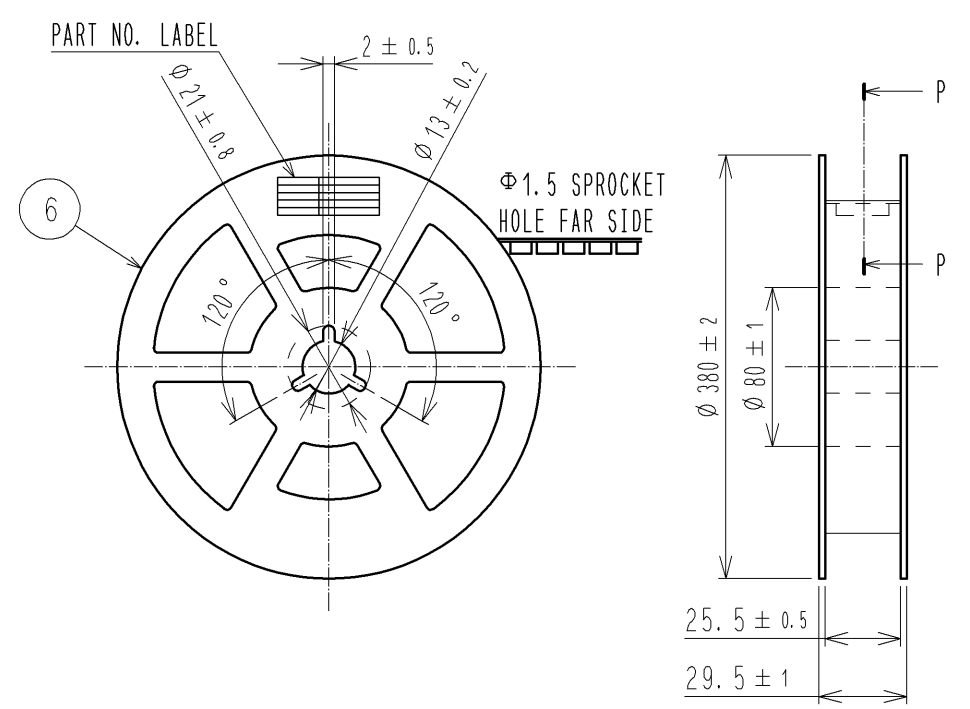

#### P-P (FREE)

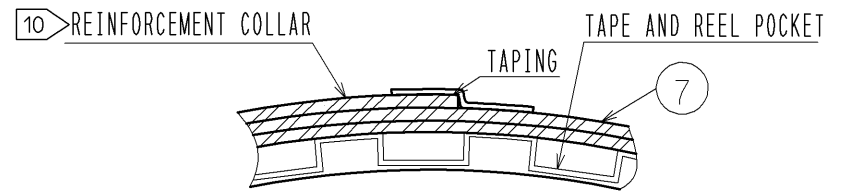

#### DETAIL OF PART NO. LABEL

製造年月日	** ** *
製品コード	CL0684-9011-9-(51)
製品名	BM20B(0.8)-30DS-0.4V(51)
数量	8,000
納入者	ヒロセ電機(株)

DATA OF MANUFACTURED  
CODE NO.  
PART NO.  
QUANTITY  
SUPPLIER

- 7. PER REEL 8000 CONNECTORS.
- 8. THE DIMENSIONS IN PARENTHESSES ARE FOR REFERENCE.
- 9 REFER TO JIS C 0806(PACKAGING OF COMPONENTS FOR AUTOMATIC HANDLING)
- 10 AFTER PACKAGING, ROLL 2 METERS OF THE REINFORCEMENT COLLAR TO OUTER CIRCUMFERENCE OF TAPE AND REEL POCKET. AND TAPE DOWN AT THE END THE COLLAR.

<b>HRS</b>	DRAWING NO.	EDC3-332317-01
	PART NO.	BM20B(0.8)-30DS-0.4V(51)
	CODE NO.	CL684-9011-9-51
		$\triangle$ 3/3