

May.1.2023 Copyright 2023 HIROSE ELECTRIC CO., LTD. All Rights Reserved.
In case of consideration for using Automotive equipment / device which demand high reliability, kindly contact our sales window correspondents.

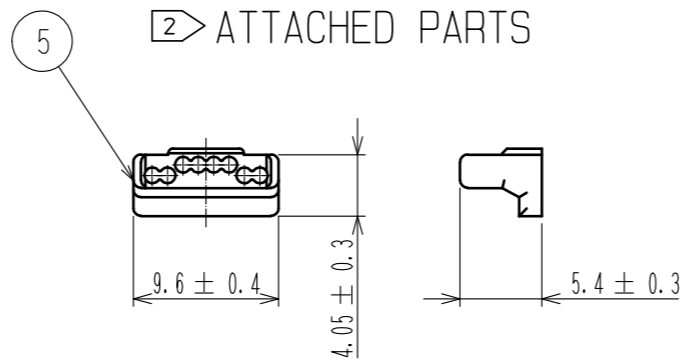

① TABLE-1

APPLICABLE CABLE WIRE		
	CONDUCTOR	AWG#24 STRANDED WIRE ~ AWG#27 STRANDED WIRE
	INSULATOR DIAMETER	($\phi 0.9 \sim \phi 1.0$)
JACKET DIAMETER		($\phi 5.8 \sim \phi 6.0$)

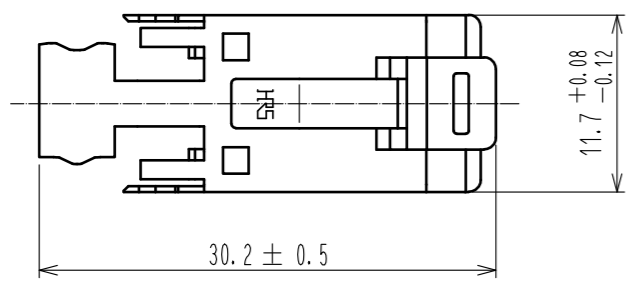
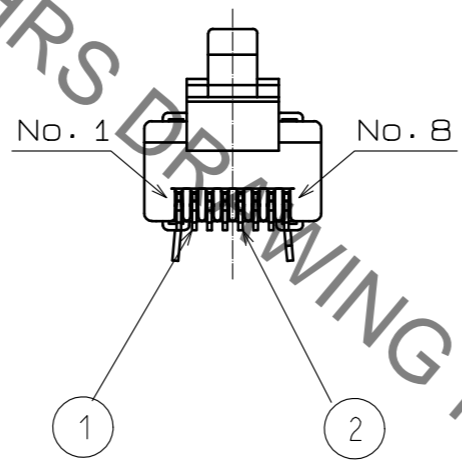
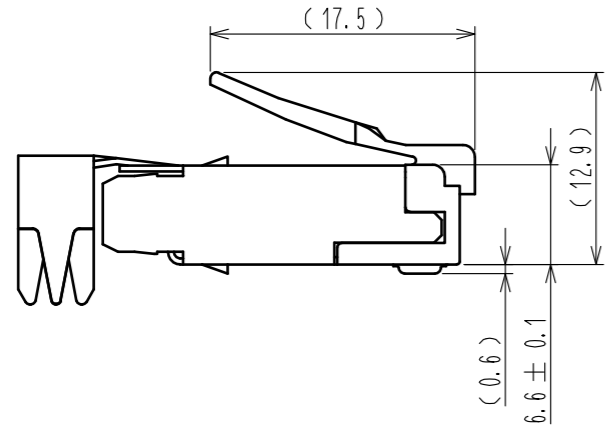

HRS DRAWING FOR REFERENCE

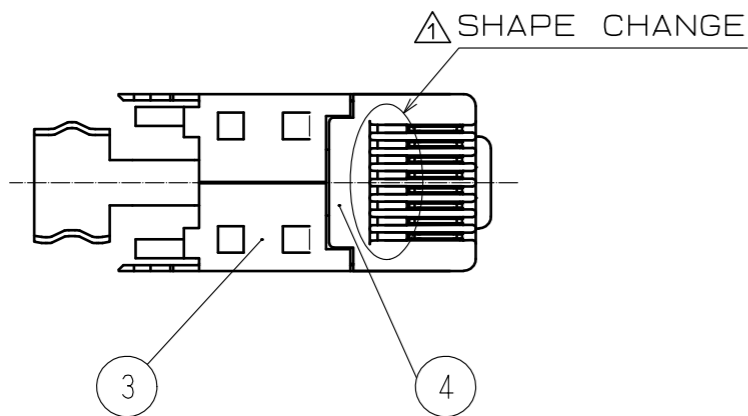

- NOTES
- ① APPLICABLE CABLE IS SHOWN IN TABLE-1
 - ② PLEASE USE ACCESSORY AS A GUIDE PLATE AND ASSEMBLE CONNECTOR WITH CABLE INSERTING ACCESSORY INTO CONNECTOR.
 - ③ () INDICATES THE REFERENCE DIMENSIONS.
 - ④ TO SATISFY CAT6a PERFORMANCE, PLEASE ASSEMBLE ACCORDING TO HRS INSTRUCTION. (ETAD-E2847)
 - ⑤ COLORS ARE DIFFERENT DEPENDING ON THE SPECIFICATION NUMBER.

⑤ CL222-2862-9-**
TM21P-88P(**)

COVER(SOLD SEPARATEIL)MATED

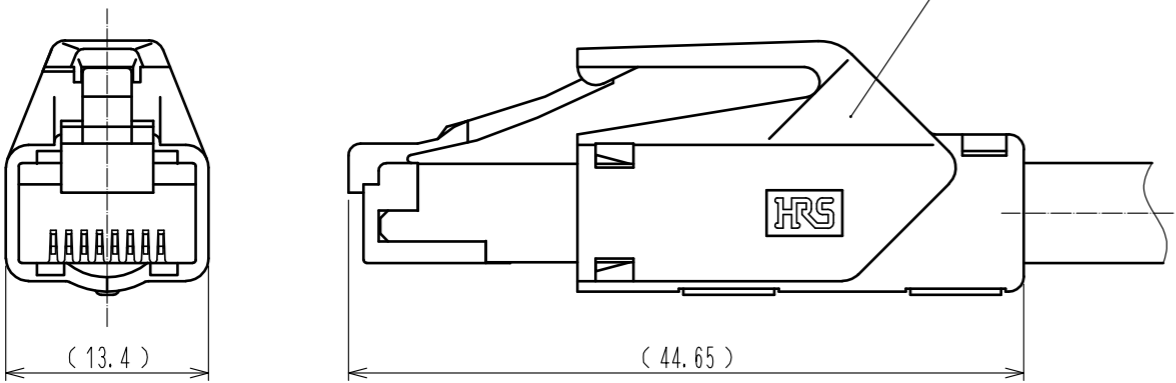

2	PHOSPHOR BRONZE	CONTACT: GOLD PLATING 1.27 μ m MIN LEAD: GOLD PLATING 0.03 μ m MIN UNDER: NICKEL PLATING 2 μ m MIN			
1	PHOSPHOR BRONZE	CONTACT: GOLD PLATING 1.27 μ m MIN LEAD: GOLD PLATING 0.03 μ m MIN UNDER: NICKEL PLATING 2 μ m MIN	5	POLYCARBONATE	(YELLOW)UL94V-2
			4	POLYCARBONATE	(YELLOW)UL94V-2
			3	STAINLESS STEEL	OVER:NICKEL PLATING 0.5 μ m MIN
NO.	MATERIAL	FINISH . REMARKS	NO.	MATERIAL	FINISH . REMARKS
UNITS mm		SCALE 2 : 1	COUNT 1	DESCRIPTION OF REVISIONS DIS-E-00003330	
DESIGNED KIM JAEHYEON		CHECKED TU. TANIGUCHI		DATE 20210309	
APPROVED : YH. ENAMI		20090126		DRAWING NO. EDC-126868-00-00	
CHECKED : YH. ENAMI		20090126		PART NO. TM31P-TM-88P	
DESIGNED : MT. ITANO		20090126		CODE NO. CL0222-4626-7-00	
DRAWN : MT. ITANO		20090126		①/1	