



Tsi350A™ PCI-to-PCI Bridge User Manual

80D5000_MA001_08

September 5, 2009

6024 Silver Creek Valley Road, San Jose, California 95138
Telephone: (800) 345-7015 • (408) 284-8200 • FAX: (408) 284-2775
Printed in U.S.A.
©2009 Integrated Device Technology, Inc.

GENERAL DISCLAIMER

Integrated Device Technology, Inc. reserves the right to make changes to its products or specifications at any time, without notice, in order to improve design or performance and to supply the best possible product. IDT does not assume any responsibility for use of any circuitry described other than the circuitry embodied in an IDT product. The Company makes no representations that circuitry described herein is free from patent infringement or other rights of third parties which may result from its use. No license is granted by implication or otherwise under any patent, patent rights or other rights, of Integrated Device Technology, Inc.

CODE DISCLAIMER

Code examples provided by IDT are for illustrative purposes only and should not be relied upon for developing applications. Any use of the code examples below is completely at your own risk. IDT MAKES NO REPRESENTATIONS OR WARRANTIES OF ANY KIND CONCERNING THE NONINFRINGEMENT, QUALITY, SAFETY OR SUITABILITY OF THE CODE, EITHER EXPRESS OR IMPLIED, INCLUDING WITHOUT LIMITATION ANY IMPLIED WARRANTIES OF MERCHANTABILITY, FITNESS FOR A PARTICULAR PURPOSE, OR NON-INFRINGEMENT. FURTHER, IDT MAKES NO REPRESENTATIONS OR WARRANTIES AS TO THE TRUTH, ACCURACY OR COMPLETENESS OF ANY STATEMENTS, INFORMATION OR MATERIALS CONCERNING CODE EXAMPLES CONTAINED IN ANY IDT PUBLICATION OR PUBLIC DISCLOSURE OR THAT IS CONTAINED ON ANY IDT INTERNET SITE. IN NO EVENT WILL IDT BE LIABLE FOR ANY DIRECT, CONSEQUENTIAL, INCIDENTAL, INDIRECT, PUNITIVE OR SPECIAL DAMAGES, HOWEVER THEY MAY ARISE, AND EVEN IF IDT HAS BEEN PREVIOUSLY ADVISED ABOUT THE POSSIBILITY OF SUCH DAMAGES. The code examples also may be subject to United States export control laws and may be subject to the export or import laws of other countries and it is your responsibility to comply with any applicable laws or regulations.

LIFE SUPPORT POLICY

Integrated Device Technology's products are not authorized for use as critical components in life support devices or systems unless a specific written agreement pertaining to such intended use is executed between the manufacturer and an officer of IDT.

1. Life support devices or systems are devices or systems which (a) are intended for surgical implant into the body or (b) support or sustain life and whose failure to perform, when properly used in accordance with instructions for use provided in the labeling, can be reasonably expected to result in a significant injury to the user.
2. A critical component is any components of a life support device or system whose failure to perform can be reasonably expected to cause the failure of the life support device or system, or to affect its safety or effectiveness.

IDT, the IDT logo, and Integrated Device Technology are trademarks or registered trademarks of Integrated Device Technology, Inc.

About this Document

This section discusses the following topics:

- “Scope” on page 3
- “Document Conventions” on page 3
- “Revision History” on page 4

Scope

The *Tsi350A PCI-to-PCI Bridge User Manual* discusses the features, capabilities, and configuration requirements for the Tsi350A. It is intended for hardware and software engineers who are designing system interconnect applications with the device.

Document Conventions

This document uses the following conventions.

Non-differential Signal Notation

Non-differential signals are either active-low or active-high. An active-low signal has an active state of logic 0 (or the lower voltage level), and is denoted by a lowercase “b”. An active-high signal has an active state of logic 1 (or the higher voltage level), and is not denoted by a special character. The following table illustrates the non-differential signal naming convention.

State	Single-line signal	Multi-line signal
Active low	NAME_b	NAME _n [3]
Active high	NAME	NAME[3]

Object Size Notation

- A *byte* is an 8-bit object.
- A *word* is a 16-bit object.
- A *doubleword* (Dword) is a 32-bit object.

Numeric Notation

- Hexadecimal numbers are denoted by the prefix *0x* (for example, 0x04).

- Binary numbers are denoted by the prefix *0b* (for example, 0b010).
- Registers that have multiple iterations are denoted by {x..y} in their names; where *x* is first register and address, and *y* is the last register and address. For example, REG{0..1} indicates there are two versions of the register at different addresses: REG0 and REG1.

Symbols



This symbol indicates a basic design concept or information considered helpful.



This symbol indicates important configuration information or suggestions.



This symbol indicates procedures or operating levels that may result in misuse or damage to the device.

Document Status Information

- Advance – Contains information that is subject to change, and is available once prototypes are released to customers.
- Preliminary – Contains information about a product that is near production-ready, and is revised as required.
- Formal – Contains information about a final, customer-ready product, and is available once the product is released to production.

Revision History

80D5000_MA001_08, Formal, September 2009

This document was rebranded as IDT. It does not include any technical changes.

80D5000_MA001_07, Formal, April 2008

This document supports the production version of the Tsi350A. The asynchronous mode functionality was removed from this document. Information has been removed from “**Secondary Clock Outputs**” on page 84 and pin 52 in “**208-pin PQFP Pin List**” on page 104 was changed from ASYNC_MODE to VSS.

80D5000_MA001_06, Formal, January 2008

This document supported the production version of the Tsi350A. The Tsi350A is a performance enhancement of the Tsi350 and there are no functional changes between the devices. All technical information in this document applies to both the Tsi350 and the Tsi350A.

80D5000_MA001_05, Formal, August 2007

The changes to this document were minor and include register address clarifications in the register chapter and a compliance list added to the overview chapter.

80D5000_MA001_04, Formal, March 2007

The following chapters were extensively edited:

- “Signals and Pinout” on page 93
- “Electrical Characteristics” on page 119
- “Package Information” on page 169

Contents

About this Document	3
Scope	3
Document Conventions	3
Revision History	4
1. Functional Overview	17
1.1 Overview of the Tsi350A	17
1.1.1 Features	19
1.1.2 Compliance	20
1.2 Functional Description	20
1.2.1 PCI Interface	20
1.2.2 JTAG Controller	21
1.2.3 Hot Swap Interface	21
1.3 Architecture	22
1.4 Data Path	22
1.4.1 Posted Write Queue	23
1.4.2 Delayed Transaction Queue	23
1.4.3 Read Data Queue	24
2. PCI Interface	25
2.1 Transaction Types	25
2.2 Transaction Phases	27
2.2.1 Address Phase	27
2.2.2 Data Phase	28
2.3 Write Transactions	28
2.3.1 Posted Write Transactions	28
2.3.2 Memory Write and Invalidate Transactions	29
2.3.3 Delayed Write Transactions	30
2.3.4 Write Transaction Address Boundaries	31
2.3.5 Buffering Multiple Write Transactions	31
2.4 Read Transactions	32
2.4.1 Calculating the Prefetch Count	33
2.4.2 Prefetchable Read Transactions	34
2.4.3 Non-Prefetchable Read Transactions	34
2.4.4 Read Prefetch Address Boundaries	34
2.4.5 Delayed Read Requests	35
2.5 Configuration Transactions	37
2.5.1 Type 0 Access to Tsi350A	38
2.5.2 Type 1 to Type 0 Translation	38
2.5.3 Type 1 to Type 1 Forwarding	41

2.6	Transaction Termination	42
2.6.1	Master Termination Initiated by Tsi350A	43
2.6.2	Master Abort Received by Tsi350A	43
2.6.3	Target Termination Received by Tsi350A	44
2.6.4	Target Termination Initiated by Tsi350A	46
3.	Address Decoding	49
3.1	Overview of Address Decoding	49
3.2	Address Ranges	49
3.3	Address Decoding	49
3.3.1	Base and Limit Address Registers	50
3.3.2	ISA Mode	51
3.4	Memory Address Decoding	51
3.4.1	Memory-Mapped I/O Base and Limit Address Registers	52
3.4.2	Prefetchable Memory Base and Limit Address Registers	53
3.4.3	Prefetchable Memory 64-Bit Addressing Registers	54
3.5	VGA Support	55
3.5.1	VGA Mode	55
3.5.2	VGA Snoop Mode	56
4.	Transaction Ordering	57
4.2	Transaction Governed by Ordering Rules	57
4.3	General Ordering Guidelines	58
4.3.1	Ordering Rules	59
5.	Error Handling	61
5.2	Address Parity Errors	61
5.3	Data Parity Errors	62
5.3.1	Configuration Write Transactions to Tsi350A Configuration Space	62
5.3.2	Read Transactions	62
5.3.3	Delayed Write Transactions	63
5.3.4	Posted Write Transactions	65
5.4	System Error (SERR_b) Reporting	66
6.	Exclusive Access	69
6.1	Concurrent Locks	69
6.2	Acquiring Exclusive Access Across the Tsi350A	69
6.3	Ending Exclusive Access	70
7.	PCI Bus Arbitration	73
7.1	Overview	73
7.2	Primary PCI Bus Arbitration	73
7.3	Secondary PCI Bus Arbitration	74
7.3.1	Secondary Bus Arbitration Using the Internal Arbiter	74
7.3.2	Secondary Bus Arbitration Using an External Arbiter	75
7.4	Bus Parking	75

8. General Purpose I/O	77
8.1 Overview	77
8.2 GPIO Control Registers	77
8.3 Secondary Clock Control	78
8.4 Live Insertion	80
8.5 CompactPCI Hot-swap Support	80
9. Clocks	83
9.1 Overview	83
9.2 Primary and Secondary Clock Inputs	83
9.2.1 Synchronous Secondary Clock Input	83
9.2.2 Asynchronous Secondary Clock Input	83
9.3 Secondary Clock Outputs	84
9.3.1 Running the Secondary Clock Faster than the Primary Clock	84
10. PCI Power Management	85
11. Reset	87
11.1 Primary Interface Reset	87
11.2 Secondary Interface Reset	87
11.3 Chip Reset	88
12. JTAG Module	89
12.2 JTAG Signal Pins	89
12.3 Test Access Port (TAP) Controller	90
12.3.1 Instruction Register	90
12.3.2 Bypass Register	90
12.3.3 Boundary-Scan Register	91
12.4 Initialization	91
13. Signals and Pinout	93
13.2 Signals	95
13.2.1 Primary PCI Bus Interface Signals	95
13.2.2 Secondary PCI Bus Interface Signals	97
13.2.3 Secondary Bus Arbitration Signals	99
13.2.4 Clock Signals	100
13.2.5 Reset Signals	101
13.2.6 Miscellaneous Signals	101
13.2.7 JTAG Signals	103
13.2.8 Power and Ground Pins	103
13.3 Pinout	104
13.3.1 208-pin PQFP Pin List	104
13.3.2 256-pin PBGA Pin List	112

14. Electrical Characteristics	119
14.1 Absolute Maximum Ratings	119
14.2 Recommended Operating Conditions	119
14.3 Power Characteristics	120
14.4 Power Supply Sequencing	120
14.5 DC Specifications	120
14.6 AC Timing Specifications	122
15. Registers	125
15.1.1 Reserved Register Addresses and Fields	127
15.2 PCI-to-PCI Bridge Standard Configuration Registers	128
15.2.1 Vendor ID Register—Offset 0x00	128
15.2.2 Device ID Register—Offset 0x00	128
15.2.3 Primary Command Register—Offset 0x04	129
15.2.4 Primary Status Register—Offset 0x04	131
15.2.5 Revision ID Register—Offset 0x08	133
15.2.6 Programming Interface Register—Offset 0x08	133
15.2.7 Subclass Code Register—Offset 0x08	133
15.2.8 Base Class Code Register—Offset 0x08	134
15.2.9 Cache Line Size Register—Offset 0x0C	135
15.2.10 Primary Latency Timer Register—Offset 0x0C	135
15.2.11 Header Type Register—Offset 0x0C	135
15.2.12 Primary Bus Number Register—Offset 0x18	136
15.2.13 Secondary Bus Number Register—Offset 0x18	136
15.2.14 Subordinate Bus Number Register—Offset 0x18	137
15.2.15 Secondary Latency Timer Register—Offset 0x18	137
15.2.16 I/O Base Address Register—Offset 0x1C	138
15.2.17 I/O Limit Address Register—Offset 0x1C	138
15.2.18 Secondary Status Register—Offset 0x1C	139
15.2.19 Memory Base Address Register—Offset 0x20	141
15.2.20 Memory Limit Address Register—Offset 0x20	141
15.2.21 Prefetchable Memory Base Address Register—Offset 0x24	142
15.2.22 Prefetchable Memory Limit Address Register—Offset 0x24	142
15.2.23 Prefetchable Memory Base Address Upper 32 Bits Register—Offset 0x28	143
15.2.24 Prefetchable Memory Limit Address Upper 32 Bits Register—Offset 0x2C	144
15.2.25 I/O Base Address Upper 16 Bits Register—Offset 0x30	145
15.2.26 I/O Limit Address Upper 16 Bits Register—Offset 0x30	145
15.2.27 ECP Pointer Register—Offset 0x34	146
15.2.28 Interrupt Pin Register—Offset 0x3C	146
15.2.29 Bridge Control Register—Offset 0x3C	147
15.3 Device-Specific Configuration Registers	151
15.3.1 Chip Control Register—Offset 0x40	152
15.3.2 Diagnostic Control Register—Offset 0x40	153
15.3.3 Arbiter Control Register—Offset 0x40	154
15.3.4 Read Transaction Control Register—Offset 0x44	155

15.3.5	P_SERR_b Event Disable Register—Offset 0x64	156
15.3.6	GPIO Output Data Register—Offset 0x64	157
15.3.7	GPIO Output Enable Control Register—Offset 0x64	158
15.3.8	GPIO Input Data Register—Offset 0x64	158
15.3.9	Secondary Clock Control Register—Offset 0x68	159
15.3.10	P_SERR_b Status Register—Offset 0x68	160
15.3.11	Capability ID Register—Offset 0xDC	161
15.3.12	Next Item Pointer Register—Offset 0xDD	161
15.3.13	Power Management Capabilities Register—Offset 0xDE	162
15.3.14	Power Management Control and Status Register—Offset 0xE0	163
15.3.15	PPB Support Extensions Registers—Offset 0xE2	164
15.3.16	Data Register—Offset 0xE3	164
15.3.17	HS Capability ID Register— Offset 0xE4	165
15.3.18	HS Next Item Pointer Register— Offset 0xE5	165
15.3.19	HS Control Status Register— Offset 0xE6	166
A.	Package Information	169
A.1	Package Characteristics	169
A.1.1	208-pin PQFP Package	169
A.1.2	256-pin PBGA Package	172
A.2	Thermal Characteristics	174
A.2.1	Junction-to-Ambient Thermal Characteristics (Theta ja)	174
A.2.2	System-level Characteristics	175
A.2.3	Example on Thermal Data Usage	175
B.	Ordering Information	177
B.1	Ordering Information	177

Figures

Figure 1:	Block Diagram	18
Figure 2:	System Block Diagram	19
Figure 3:	Tsi350A Downstream Data Path	23
Figure 4:	Type 0 Configuration Transaction	37
Figure 5:	Type 1 Configuration Transaction	37
Figure 6:	Clock Mask Load and Shift Timing	79
Figure 7:	PCI Signal Timing Measurement Conditions	122
Figure 8:	208-pin PQFP Package Diagram - Top View	170
Figure 9:	208-pin PQFP Package Diagram - Side View	171
Figure 10:	208-pin PQFP Package Diagram - Side View	171
Figure 11:	256-pin PBGA Package Diagram - Top View	172
Figure 12:	256-pin PBGA Package Diagram - Bottom View	173
Figure 13:	256-pin PBGA Package Diagram - Side View	173

Tables

Table 1:	Tsi350A PCI Transactions	26
Table 2:	Write Transaction Address Boundaries	31
Table 3:	Read Transaction Prefetching	32
Table 4:	Read Prefetch Address Boundaries	35
Table 5:	Device Number to IDSEL S_AD Pin Mapping	39
Table 6:	Tsi350A Response to Delayed Write Transaction	44
Table 7:	Tsi350A Response to Posted Write Termination	45
Table 8:	Tsi350A Response to Delayed Read Target Termination	46
Table 9:	Summary of Transaction Ordering	59
Table 10:	Clock Mask Data Format	79
Table 11:	Tsi350A Hot-Swap Mode Selection	81
Table 12:	Tsi350A S_CLK_O clock outputs	84
Table 13:	Power Management Transitions	85
Table 14:	JTAG Signal Pins	89
Table 15:	JTAG Instructions	90
Table 16:	Tsi350A Signal Pins	93
Table 17:	Tsi350A Signal Types	94
Table 18:	Primary PCI Bus Interface Signals	95
Table 19:	Secondary PCI Bus Interface Signals	97
Table 20:	Secondary PCI Bus Arbitration Signals	99
Table 21:	Clock Signals	100
Table 22:	Tsi350A Reset Signals	101
Table 23:	Tsi350A Miscellaneous Signals	101
Table 24:	JTAG Signals	103
Table 25:	Power and Ground Pins	103
Table 26:	Tsi350A 208 Pin List	104
Table 27:	Tsi350A 256 Pin List	112
Table 28:	Tsi350A 256 Pin List - Power, Ground, and Reserved	117
Table 29:	Absolute Maximum Ratings	119
Table 30:	Recommended Operating Conditions	119
Table 31:	Power Characteristics	120
Table 32:	Tsi350A DC Specifications	120
Table 33:	33 MHz PCI Signal Timing	123
Table 34:	66 MHz PCI Signal Timing	123
Table 35:	Tsi350A Configuration Space	125
Table 36:	Register Access Types	127
Table 37:	PQFP Symbol Values	169
Table 38:	Thermal Characteristics of the Tsi350A	174
Table 39:	Simulated Junction to Ambient Characteristics	174
Table 40:	Ordering Information	177

1. Functional Overview

This chapter describes the main features and functions of the Tsi350A. The following topics are discussed:

- “Overview of the Tsi350A” on page 17
 - “Functional Description” on page 20
 - “Architecture” on page 22
 - “Data Path” on page 22
-

1.1 Overview of the Tsi350A

The IDT Tsi350A is a PCI-to-PCI bridge that is fully compliant with *PCI Local Bus Specification, Revision 2.3*. The Tsi350A has sufficient clock and arbitration pins to support nine PCI bus master devices directly on its secondary interface.

The Tsi350A allows the two PCI buses to operate concurrently. This means that a master and a target on the same PCI bus can communicate while the other PCI bus is busy. This traffic isolation may increase system performance in applications such as multimedia.

The Tsi350A makes it possible to extend a system’s load capability limit beyond that of a single PCI bus by allowing motherboard designers to add more PCI devices or more PCI option card slots than a single PCI bus can support.

The Tsi350A has two identical PCI Interfaces that each handle PCI transactions for its respective bus, and, depending on the type of transaction, can act as either a bus master or a bus slave. These interfaces transfer data and control information flowing to and from the blocks shown in [Figure 1](#).

Figure 1: Block Diagram

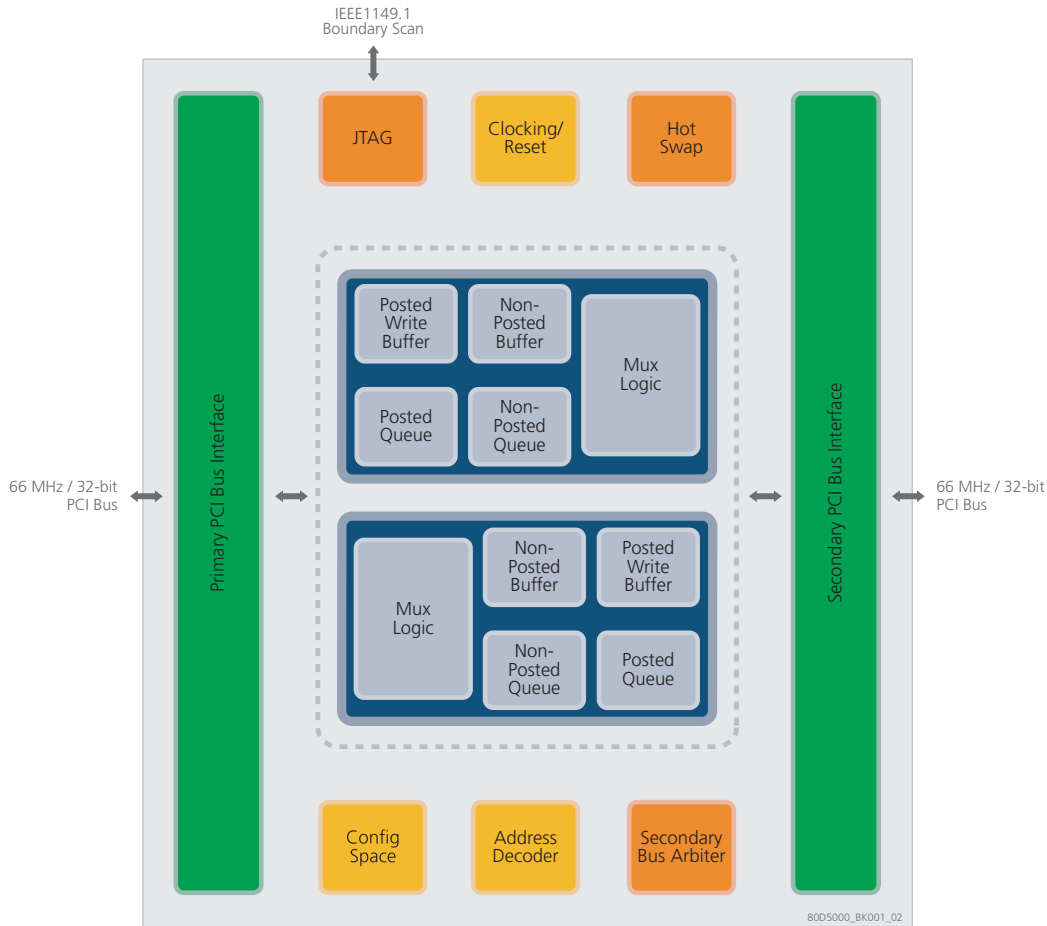

Option card designers can use Tsi350A to implement multiple-device PCI option cards. Without a PCI-to-PCI bridge, PCI loading rules would limit option cards to one device. The PCI Local Bus Specification loading rules limit PCI option cards to a single connection per PCI signal in the option card connector. The Tsi350A overcomes this restriction by providing, on the option card, an independent PCI bus to which up to nine devices can be attached.

Figure 2 shows how the Tsi350A enables the design of a multi-component option card or expand existing PCI buses.

Figure 2: System Block Diagram

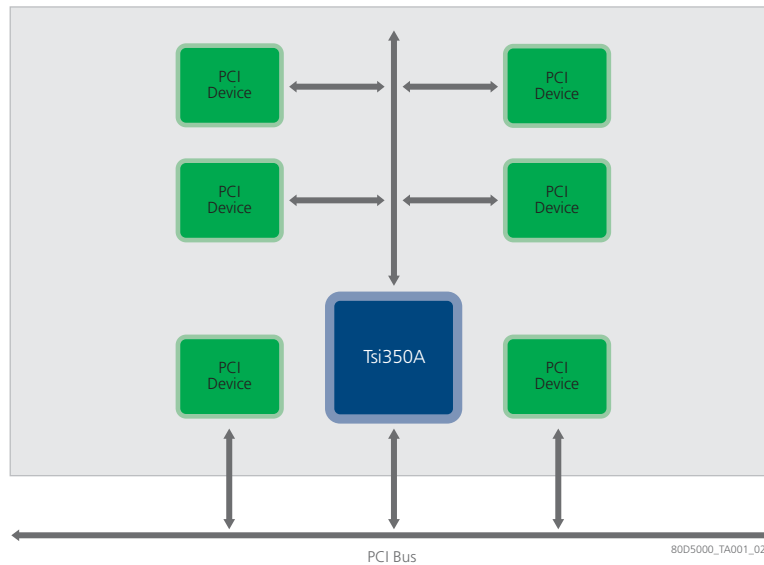

1.1.1 Features

- Industry-standard 32-bit, 66-MHz PCI bridge
- Fully *PCI Local Bus Specification, Revision 2.3* compliant
- Supports up to nine PCI bus masters on the secondary interface
- Ten independent secondary clock outputs to the secondary slots
- Primary and secondary interfaces can be operated using asynchronous clocks
- Secondary clock can either be derived from the input primary clock or supplied by an external clock source
- Secondary clocks can be masked through the GPIO interface during power up
- Supports four independent delayed transactions in each direction
- Supports up to nine secondary requests and grants
- External arbiter support on the secondary bus
- Supports CompactPCI Hot Swap functionality
- C I Power management with D3Hot support with option to disable clocks during D3Hot state
- Supports Bus Locking mechanism
- VGA/Palette memory and I/O decoding options
- Optional non-posted entry flush upon posted writes traveling the same direction
- Compatible with existing solutions from Intel, TI, PLX, and Pericom

1.1.2 Compliance

- *PCI-to-PCI Bridge Architecture Specification (Revision 1.1)*
- *PCI Local Bus Specification (Revision 2.3)*
- *PCI bus Power Management Interface Specification (Revision 1.1)*
- *Advanced Configuration Power Interface (ACPI)*
- *PICMG CompactPCI Hot-Swap Specification (Revision 2.0)*

1.2 Functional Description

This chapter outlines functionality of various interfaces and major blocks.

1.2.1 PCI Interface

Tsi350A has two PCI interfaces, one on the primary side and another on the secondary side. These interfaces transfer data/control information to and from BLU (Buffer Logic Unit).

1.2.1.1 Posted Write Buffer

This buffer is used as temporary storage for posted memory write data flowing from one interface to the other. Each posted buffer has a capacity of 128 bytes. The amount of buffer locations allotted for a transaction is dynamic. A single transaction can utilize from one memory location (4 bytes) to 32 memory locations (128 bytes) as needed.

1.2.1.2 Posted Write Queue

Posted Write Queue is used to store control information related to the posted write transaction flowing from one interface to the other. Each Posted Write Queue is a 4-entry FIFO, providing four active posted write transactions in each direction. Data related to each entry is stored in the Posted Write Buffer. Posted Write Queue will accept entry from external master only when at least one entry is free and at least one Q-word space is available in Posted Write Buffer.

1.2.1.3 Non-Posted Buffer

Non-Posted Buffer is used to hold data for read transactions. Each Non-Posted Buffer contains 128 bytes of buffer space. The amount of buffer locations allotted for a transaction is dynamic. A single transaction can utilize from one memory location (4 bytes) to 32 memory locations (128 bytes) as needed. Tsi350A will start giving data on originating bus once the first four locations of the buffer are filled or the transaction is completed on the target bus.

1.2.1.4 Non-Posted Queue

Non-Posted Queue is used to store the control information related to the all non-posted transactions. Each Non-Posted Queue is a 4-entry FIFO, providing 4-active non-posted transactions in each direction. Data related to each entry is stored in the Non-Posted Buffer. The Non-Posted Queue will accept a transaction from external master only when at least one entry is free.

1.2.1.5 Mux Logic

This module arbitrates the transactions from the Posted Queue and Non-Posted Queue.

1.2.1.6 Configuration Space

The configuration registers help the system software to configure behavior of the bridge. The bridge has Type 01 configuration header support as per the specification. All of these registers function exactly as specified in the *PCI to PCI Bridge Architecture Specification, Revision 1.2*. The configuration space can be accessed only from primary bus interface. Tsi350A implements device specific configuration registers to enable software to program the bridge features.

1.2.1.7 Address Decoding Logic

Tsi350A operates in transparent mode. In transparent mode I/O, memory, pre-fetchable memory base and limit, and optional Base Address Registers 0 and 1 define address ranges for the devices residing on secondary bus. All other addresses are assumed to reside on the primary bus. Inverse address decoding determines when to forward a transaction up-stream.

1.2.1.8 Secondary Bus Arbiter

Tsi350A is designed with an internal arbiter that can be enabled through input strap S_CFN_b. The arbiter provides bus arbitration for nine additional masters. The arbiter can be programmed to enable/disable and prioritize each request independently through software.

Tsi350A implements 2-level arbitration scheme. The requesters are divided into 2 groups, a high priority group and a low priority group. Each master can be assigned to either high or low priority group through the configuration register.

1.2.2 JTAG Controller

Tsi350A provides a JTAG test port that is compliant with IEEE Standard 1149.1, *IEEE Standard Test Access Port and Boundary-Scan Architecture*, to facilitate card and board testing using boundary scan techniques. This function consists of five-signal test port interface with signals TCK, TDI, TDO, TMS, and TRST.

1.2.3 Hot Swap Interface

Tsi350A is designed with an interface for Hot Swap support. This allows the user to insert or extract the bridge card without powering down the system. During insertion and extraction process, the bridge indicates to system software about the Hot Swap event by driving HS_ENUM_b. It also provides a visual indication to the user through the HS_LED signal.



Hot-Swap support is implemented in the 208-pin PQFP package only. The 256-pin PBGA package does not support Hot Swap.

1.3 Architecture

Tsi350A internal architecture consists of the following major functions:

- PCI interface control logic for the primary and secondary PCI interfaces
- Data path and data path control logic
- Configuration register and configuration control logic
- Secondary bus arbiter

1.4 Data Path

The data path consists of a primary-to-secondary data path for transactions and data flowing in the downstream direction and a secondary-to-primary data path for transactions and data flowing in the upstream direction.

Both data paths have the following queues:

- Posted write queue
- Delayed transaction queue
- Read data queue

To prevent deadlocks and to maintain data coherency, a set of ordering rules is imposed on the forwarding of posted and delayed transactions across Tsi350A. The queue structure, along with the order in which the transactions in the queues are initiated and completed, supports these ordering requirements.

Figure 3 shows the Tsi350A data path for the downstream direction, and the following sections describe the data path queues.

Figure 3: Tsi350A Downstream Data Path

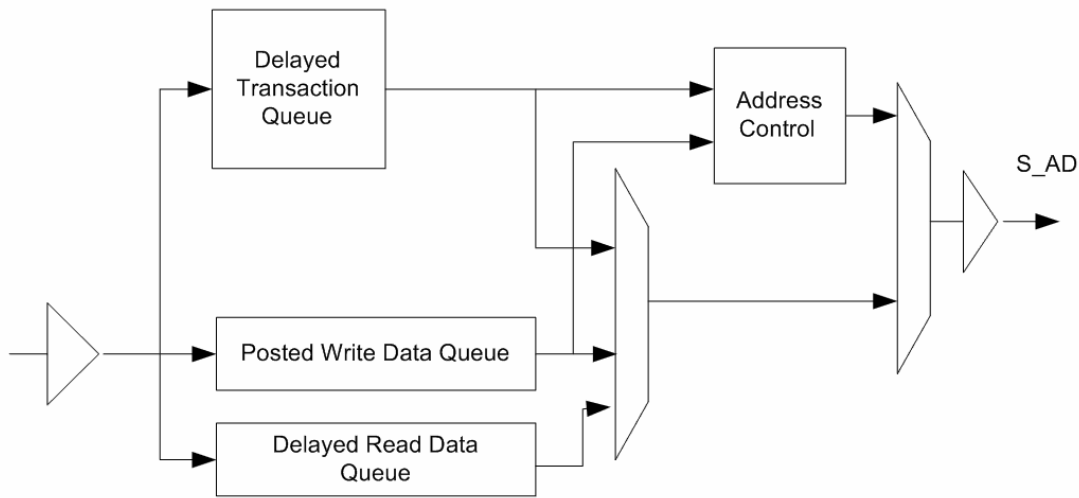

1.4.1 Posted Write Queue

The posted write queue contains the address and data of memory write transactions targeted for the opposite interface. The posted write transaction can consist of an arbitrary number of data phases, subject to the amount of space in the queue and disconnect boundaries. The posted write queue can contain multiple posted write transactions. The number of posted write transactions that can be queued at one time is dependent upon their burst size. The posted write queue consists of 128 bytes in each direction.

1.4.2 Delayed Transaction Queue

For a delayed write request transaction, the delayed transaction queue contains the address, bus command, 1 Dword of write data, byte enable bits, and parity. When the delayed write transaction is completed on the target bus, the write completion status is added to the corresponding entry. For a delayed read request transaction, the delayed transaction queue contains the address and bus command - and for non-prefetchable read transactions - the byte enable bits. When the delayed read transaction is completed on the target bus, the read completion status corresponding to that transaction is added to the delayed request entry. Read data is placed in the read data queue. The delayed transaction queue can hold up to four transactions (any combination of read and write transactions).

1.4.3 Read Data Queue

The read data queue contains read data transferred from the target during a delayed read completion. Read data travels in the opposite direction of the transaction. The primary-to-secondary read data queue contains read data corresponding to a delayed read transaction residing in the secondary-to-primary delayed transaction queue. The secondary-to-primary read data queue contains read data corresponding to a delayed read transaction in the primary-to-secondary delayed transaction queue. The amount of read data per transaction depends on the amount of space in the queue and disconnect boundaries. Read data for up to four transactions, subject to the burst size of the read transactions and available queue space, can be stored. The read data queue for Tsi350A consists of 128 bytes in each direction.

2. PCI Interface

This chapter discusses the following topics:

- “Transaction Types” on page 25
- “Transaction Phases” on page 27
- “Write Transactions” on page 28
- “Read Transactions” on page 32
- “Configuration Transactions” on page 37
- “Transaction Termination” on page 42

2.1 Transaction Types

This section summarizes the PCI transactions performed by Tsi350A.

Table 1 lists the command code and name of each PCI transaction. The Master and Target columns indicate Tsi350A support for each transaction when Tsi350A initiates transactions as a master, on the primary bus and on the secondary bus, and when Tsi350A responds to transactions as a target, on the primary bus and on the secondary bus.

As indicated in **Table 1**, the following PCI commands are not supported by Tsi350A:

- Tsi350A never initiates a PCI transaction with a reserved command code and, as a target Tsi350A ignores reserved command codes.
- Tsi350A never initiates an interrupt acknowledge transaction and, as a target, Tsi350A ignores interrupt acknowledge transactions. Interrupt acknowledge transactions are expected to reside entirely on the primary PCI bus closest to the host bridge.
- Tsi350A does not respond to special cycle transactions. Tsi350A cannot guarantee delivery of a special cycle transaction to downstream buses because of the broadcast nature of the special cycle command and the inability to control the transaction as a target. To generate special cycle transactions on other PCI buses, either upstream or downstream, a Type 1 configuration command must be used.

- Tsi350A does not generate Type 0 configuration transactions on the primary interface, nor does it respond to Type 0 configuration transactions on the secondary PCI interface. The *PCI-to-PCI Bridge Architecture Specification* does not support configuration from the secondary bus.

Table 1: Tsi350A PCI Transactions

Command	Type of Transaction	Initiates as a Master		Responds as a Target	
		Primary	Secondary	Primary	Secondary
0000	Interrupt Acknowledge	No	No	No	No
0001	Special Cycle	Yes	Yes	No	No
0010	I/O Read	Yes	Yes	Yes	Yes
0011	I/O Write	Yes	Yes	Yes	Yes
0100	Reserved	No	No	No	No
0101	Reserved	No	No	No	No
0110	Memory Read	Yes	Yes	Yes	Yes
0111	Memory Write	Yes	Yes	Yes	Yes
1000	Reserved	No	No	No	No
1001	Reserved	No	No	No	No
1010	Configuration read	No	Yes	Yes	No
1011	Configuration Write	Type 1	Yes	Yes	Type 1
1100	Memory Read Multiple	Yes	Yes	Yes	Yes
1101	Dual Address Cycle	Yes	Yes	Yes	Yes
1110	Memory Read Line	Yes	Yes	Yes	Yes
1111	Memory Write and Invalidate	Yes	Yes	Yes	Yes

2.2 Transaction Phases

2.2.1 Address Phase

The standard PCI transaction consists of one or two address phases, followed by one or more data phases. An address phase always lasts one PCI clock cycle. The first address phase is designated by an asserting (falling) edge on the FRAME_b signal. The number of address phases depends on whether the address is 32 bits or 64 bits.

2.2.1.1 Single Address Phase

A 32-bit address uses a single address phase. This address is driven on AD[31:0], and the bus command is driven on C/BE_b[3:0]. Tsi350A supports the linear increment address mode only, which is indicated when the lower two address bits are equal to 0. If either of the lower two address bits is nonzero, Tsi350A automatically disconnects the transaction after the first data transfer.

2.2.1.2 Dual Address Phase

Dual address transactions are PCI transactions that contain the following two address phases specifying a 64-bit address:

- The first address phase is denoted by the asserting edge of FRAME_b.
- The second address phase always follows on the next clock cycle.

The first address phase contains the dual address command code on the C/BE_b[3:0] lines, and the low 32 address bits on the AD[31:0] lines. The second address phase consists of the specific memory transaction command code on the C/BE_b[3:0] lines and the high 32 address bits on the AD[31:0] lines. In this way, 64-bit addressing can be supported on 32-bit PCI buses.

The *PCI-to-PCI Bridge Architecture Specification* supports the use of dual address transactions in the prefetchable memory range only. Tsi350A supports dual address transactions in both the upstream and the downstream direction. Tsi350A supports a programmable 64-bit address range in prefetchable memory for downstream forwarding of dual address transactions. Dual address transactions falling outside the prefetchable address range are forwarded upstream, but not downstream. Prefetching and posting are performed in a manner consistent with the guidelines given in this specification for each type of memory transaction in prefetchable memory space.

Any memory transactions addressing the first 4 GB space should use a single address phase; that is, the high 32 bits of a dual address transaction should never be 0.

Tsi350A responds only to dual address transactions that use the following transaction command codes:

- Memory Write
- Memory Write and Invalidate
- Memory Read
- Memory Read Line

- Memory Read Multiple



Use of other transaction codes may result in a master abort.

2.2.1.3 Device Select (DEVSEL_b) Generation

Tsi350A always performs positive address decoding when accepting transactions on either the primary or secondary buses. Tsi350A never subtractively decodes. Medium DEVSEL_b timing is used on both interfaces.

2.2.2 Data Phase

The address phase or phases of a PCI transaction are followed by one or more data phases. A data phase is completed when IRDY_b and either TRDY_b or STOP_b are asserted. A transfer of data occurs only when both IRDY_b and TRDY_b are asserted during the same PCI clock cycle. The last data phase of a transaction is indicated when FRAME_b is de-asserted and both TRDY_b and IRDY_b are asserted, or when IRDY_b and STOP_b are asserted (see [“Transaction Termination” on page 42](#) for further discussion of transaction termination).

Depending on the command type, Tsi350A can support multiple data phase PCI transactions. For a detailed description of how Tsi350A imposes disconnect boundaries, see [“Write Transactions” on page 28](#) for a description of write address boundaries and [“Read Transactions” on page 32](#) for a description of read address boundaries.

2.3 Write Transactions

Write transactions are treated as either posted write or delayed write transactions.

2.3.1 Posted Write Transactions

Posted write forwarding is used for memory write and for memory write and invalidate transactions.

When Tsi350A determines that a memory write transaction is to be forwarded across the bridge, Tsi350A asserts DEVSEL_b with medium timing and TRDY_b in the next cycle, provided that enough buffer space is available in the posted data queue for the address and at least 8 Dwords of data. This enables Tsi350A to accept write data without obtaining access to the target bus. Tsi350A can accept one Dword of write data every PCI clock cycle; that is, no target wait states are inserted. This write data is stored in internal posted write buffers and is subsequently delivered to the target.

Tsi350A continues to accept write data until one of the following events occurs:

- The initiator terminates the transaction by de-asserting FRAME_b and IRDY_b.
- An internal write address boundary is reached, such as a cache line boundary or an aligned 4 kB boundary, depending on the transaction type.
- The posted write data buffer fills up.

When one of the last two events occurs, Tsi350A returns a target disconnect to the requesting initiator on this data phase to terminate the transaction. Once the posted write data moves to the head of the posted data queue, Tsi350A asserts its request on the target bus. This can occur while Tsi350A is still receiving data on the initiator bus. When the grant for the target bus is received and the target bus is detected in the idle condition, Tsi350A asserts `FRAME_b` and drives the stored write address out on the target bus. On the following cycle, Tsi350A drives the first Dword of write data and continues to transfer write data until all write data corresponding to that transaction is delivered, or until a target termination is received. As long as write data exists in the queue, Tsi350A can drive 1 Dword of write data each PCI clock cycle.

Tsi350A ends the transaction on the target bus when one of the following conditions is met:

- All posted write data has been delivered to the target.
- The target returns a target disconnect or target retry (Tsi350A starts another transaction to deliver the rest of the write data)
- The target returns a target abort (Tsi350A discards remaining write data).
- The master latency timer expires, and Tsi350A no longer has the target bus grant (Tsi350A starts another transaction to deliver remaining write data).

2.3.2 Memory Write and Invalidate Transactions

Posted write forwarding is used for memory write and invalidate transactions. Memory write and invalidate transactions guarantee transfer of entire cache lines. If the write buffer fills before an entire cache line is transferred, Tsi350A disconnects the transaction and converts it to a memory write transaction.

Tsi350A disconnects memory write and invalidate commands at aligned cache line boundaries. The cache line size value in Tsi350A cache line size register gives the number of Dwords in a cache line. For Tsi350A to generate memory write and invalidate transactions, this cache line size value must be written to a value that is a nonzero power of two and less than or equal to 16 (that is, 1, 2, 4, 8, or 16 Dwords).

If the cache line size does not meet the memory write and invalidate conditions, that is, the value is 0 or is not a power of two or is greater than 16 Dwords, Tsi350A treats the memory write and invalidate command as a memory write command. In this case, when Tsi350A forwards the memory write and invalidate transaction to the target bus, it converts the command code to a memory write code and does not observe cache line boundaries.

If the value in the cache line size register does meet the memory write and invalidate conditions, that is, the value is a nonzero power of 2 less than or equal to 16 Dwords, Tsi350A returns a target disconnect to the initiator either on a cache line boundary or when the posted write buffer fills. For a cache line size of 16 Dwords, Tsi350A disconnects a memory write and invalidate transaction on every cache line boundary. When the cache line size is 1, 2, 4, or 8 Dwords, Tsi350A accepts another cache line if at least 8 Dwords of empty space remains in the posted write buffer. If less than 8 Dwords of empty space remains, Tsi350A disconnects on that cache line boundary. When the memory write and invalidate transaction is disconnected before a cache line boundary is reached, typically because the posted write buffer fills, the transaction is converted to a memory write transaction.

2.3.3 Delayed Write Transactions

Delayed write forwarding is used for I/O write transactions and for Type 1 configuration write transactions.

A delayed write transaction guarantees that the actual target response is returned back to the initiator without holding the initiating bus in wait states. A delayed write transaction is limited to a single Dword data transfer.

When a write transaction is first detected on the initiator bus, and Tsi350A forwards it as a delayed transaction, Tsi350A claims the access by asserting DEVSEL_b and returns a target retry to the initiator. During the address phase, Tsi350A samples the bus command, address, and address parity one cycle later. After IRDY_b is asserted, Tsi350A also samples the first data Dword, byte enable bits, and data parity. This information is placed into the delayed transaction queue. The transaction is queued only if no other existing delayed transactions have the same address and command, and if the delayed transaction queue is not full. When the delayed write transaction moves to the head of the delayed transaction queue and all ordering constraints with posted data are satisfied, Tsi350A initiates the transaction on the target bus. Tsi350A transfers the write data to the target. If Tsi350A receives a target retry in response to the write transaction on the target bus, it continues to repeat the write transaction until the data transfer is completed, or until an error condition is encountered.

If Tsi350A is unable to deliver write data after 2^{24} attempts, Tsi350A ceases further write attempts and returns a target abort to the initiator. The delayed transaction is removed from the delayed transaction queue. Tsi350A also asserts P_SERR_b if the primary SERR_b enable bit is set in the command register.

When the initiator repeats the same write transaction (same command, address, byte enable bits, and data), and the completed delayed transaction is at the head of the queue, Tsi350A claims the access by asserting DEVSEL_b and returns TRDY_b to the initiator to indicate that the write data was transferred. If the initiator requests multiple Dwords, Tsi350A also asserts STOP_b in conjunction with TRDY_b to signal a target disconnect. Note that only those bytes of write data with valid byte enable bits are compared. If any of the byte enable bits are turned off (driven high), the corresponding byte of write data is not compared.

If the initiator repeats the write transaction before the data has been transferred to the target, Tsi350A returns a target retry to the initiator. Tsi350A continues to return a target retry to the initiator until write data is delivered to the target, or until an error condition is encountered. When the write transaction is repeated, Tsi350A does not make a new entry into the delayed transaction queue. For detailed information on how the Tsi350A responds to target termination during delayed write transactions, see [“Delayed Write Target Termination Response” on page 44](#).

Tsi350A implements a discard timer that starts counting when the delayed write completion is at the head of the delayed transaction queue. The initial value of this timer can be set to one of two values, selectable through both the primary and secondary master time-out bits in the bridge control register. If the initiator does not repeat the delayed write transaction before the discard timer expires, Tsi350A discards the delayed write transaction from the delayed transaction queue and asserts P_SERR_b (if enabled).

2.3.4 Write Transaction Address Boundaries

Tsi350A imposes internal address boundaries when accepting write data. The aligned address boundaries are used to prevent Tsi350A from continuing a transaction over a device address boundary and to provide an upper limit on maximum latency. Tsi350A returns a target disconnect to the initiator when it reaches the aligned address boundaries under the conditions shown in [Table 2](#).

Table 2: Write Transaction Address Boundaries

Type of Transaction	Condition	Aligned Address Boundary
Memory Write	Disconnect control bit = 0 (“Chip Control Register—Offset 0x40” on page 152)	4 kB aligned address boundary
Memory Write	Disconnect control bit = 1 (“Chip Control Register—Offset 0x40” on page 152)	Disconnects at n th cache line boundary
Memory Write and Invalidate	Cache line size = 1, 2, 4, 8, 16 (“Cache Line Size Register—Offset 0x0C” on page 135)	4 kB aligned address boundary
Memory Write and Invalidate	Cache line size = 1, 2, 4, 8 (“Cache Line Size Register—Offset 0x0C” on page 135)	n th cache line boundary, where a cache line boundary is reached and less than 8 free D-words of posted write buffer space remains
Memory Write and Invalidate	Cache line size = 16 (“Cache Line Size Register—Offset 0x0C” on page 135)	16-Dword aligned address boundary

2.3.5 Buffering Multiple Write Transactions

Tsi350A continues to accept posted memory write transactions as long as space for at least 1 Dword of data in the posted write data buffer remains. If the posted write data buffer fills before the initiator terminates the write transaction, Tsi350A returns a target disconnect to the initiator.

Delayed write transactions are handled as long as at least one open entry in Tsi350A delayed transaction queue exists. Therefore, several posted and delayed write transactions can exist in data buffers at the same time.

2.3.5.1 Fast Back-to-Back Write Transactions

Tsi350A can recognize fast back-to-back write transactions as a target on the PCI bus. When the bridge experiences shortage of buffer space, the fast back-to-back transaction will be retired.

Tsi350A does not perform write combining or merging.

2.4 Read Transactions

Delayed read forwarding is used for all read transactions crossing Tsi350A. Delayed read transactions are treated as either prefetchable or non-prefetchable.

Prefetching is a useful technique for hiding the latency of a burst read transaction but its use is restricted. Memory that is prefetchable has the attribute that it returns the same data when read multiple times and does not alter any other device state when it is read. It is the responsibility of the target device to disconnect a burst transaction when either a Base Address register boundary is reached, or a boundary is reached within a Base Address register where the attributes of the access change (i.e., prefetchable vs. non-prefetchable). When prefetching, the bridge may read data that is not consumed by the master. The bridge is required to discard any prefetched read data not consumed when the master concludes the read transaction

A bridge may safely prefetch data when the transaction uses the Memory Read Line or Memory Read Multiple command. Since most processor architectures do not have the notion of prefetchable memory, typical host bus bridges do not generate Memory Read Line or Memory Read Multiple transactions. A bridge may provide an optional address range that allows the bridge to prefetch memory read data from a target attached to the secondary interface of the bridge.

A bridge is permitted to prefetch data from a secondary bus if the transaction originates on the primary bus and is either a Memory Read Line or Memory Read Multiple command. A bridge is permitted to prefetch data from the primary bus if the transaction originates on the secondary bus and is either a Memory Read Line or Memory Read Multiple command. Masters attached to the secondary interface of a bridge are encouraged to use the Memory Read Line or Memory Read Multiple commands if they desire high performance read transactions. The bridge is also permitted to assume that all transactions that originate on the secondary bus and go up through the bridge have a final destination at main memory and therefore are prefetchable. When prefetching memory read data, the bridge is permitted to assert all byte enables for all data phases on the destination bus independent of the byte enables used by the originating bus master.

Table 3 shows the read behavior, prefetchable or non-prefetchable, for each type of read operation.

Table 3: Read Transaction Prefetching

Type of Transaction	Read Behavior
I/O read	Prefetching never done
Configuration read	Prefetching never done
Memory read	Downstream: Prefetching used if address in prefetchable Upstream: Prefetching used if prefetch disable is off (default).
Memory read line	Prefetching always used
Memory read multiple	Prefetching always used

2.4.1 Calculating the Prefetch Count

Tsi350A implements following registers to calculate prefetch count:

- “Cache Line Size Register—Offset 0x0C” on page 135
- “Read Transaction Control Register— Offset 0x44” on page 155

The bits in the listed registers are used to calculate the prefetch count using the following equation:

- When the Downstream Cacheline Prefetch Enable bit and the Upstream Cacheline Prefetch Enable bit in the “Read Transaction Control Register— Offset 0x44” on page 155 are 0:

— $PRE_DW_CNT = (MPC - CLS) + CLB_CNT$

— Where:

- PRE_DW_CNT is the prefetch dword count
- MPC is the Maximum Prefetch Count field in the Read Transaction Control Register
- CLS is the Cache Line Size field in the Cacheline Size Register
- CLB_CNT is the Cache Line Boundary Count

- When the Downstream Cacheline Prefetch Enable bit and the Upstream Cacheline Prefetch Enable bit in the “Read Transaction Control Register— Offset 0x44” on page 155 are set to 1:

— $PRE_DW_CNT = (MPC - CLS) + CLB_CNT$

— Where:

- PRE_DW_CNT is the prefetch dword count
- MPC is the Maximum Prefetch Count field in the Read Transaction Control Register
- CLS is the Cache Line Size field in the Cacheline Size Register
- CLB_CNT is the Cache Line Boundary Count

If the prefetch count has not reached the calculated prefetch count and flow through has been achieved, the Tsi350A keeps prefetching until one of the following occurs:

- The requesting master terminates the transaction
- Read data FIFO becomes full
- The read transaction reaches the 4 K address boundary
- A target disconnects the ongoing transaction

The following rules are true when determining the prefetch count behaviour of the Tsi350A:

- If the maximum prefetch count is programmed less than Cache Line Size, the Tsi350A prefetches data up to first cache line boundary.
- Based on the formula, prefetch count is no less than 16 Dword count for any combination of cache line size and maximum prefetch count.
- If buffer is empty, Tsi350A can prefetch more than calculated prefetch count.
- By default, the Tsi350 prefetches data up to cache line boundary. User must program bits 2 and 1 at offset 0x44 to zero to enable maximum prefetch count registers (7:6 and 5:4).

- For single D-word read transactions prefetching is ignored.
- In the case where there is a single request pending in the buffers and flow-through is established, the maximum prefetch count value programmed at offset 0x44 is ignored

2.4.2 Prefetchable Read Transactions

A prefetchable read transaction is a read transaction where the Tsi350A performs speculative Dword reads, transferring data from the target before it is requested from the initiator. This behavior allows a prefetchable read transaction to consist of multiple data transfers. However, byte enable bits cannot be forwarded for all data phases as is done for the single data phase of the non-prefetchable read transaction.

Prefetchable behavior is used for memory read line and memory read multiple transactions, as well as for memory read transactions that fall into prefetchable memory space.

The amount of data that is prefetched depends on the type of transaction. The amount of prefetching may also be affected by the amount of free buffer space available in the Tsi350A, and by any read address boundaries encountered.

2.4.3 Non-Prefetchable Read Transactions

A non-prefetchable read transaction is a read transaction where the Tsi350A requests 1—and only 1—Dword from the target and disconnects the initiator after delivery of the first Dword of read data. Unlike prefetchable read transactions, the Tsi350A forwards the read byte enable information for the data phase.

Non-prefetchable behavior is used for I/O and configuration read transactions, as well as for memory read transactions that fall into non-prefetchable memory space. If extra read transactions could have side effects, for example, when accessing a FIFO, use non-prefetchable read transactions to those locations. Accordingly, if it is important to retain the value of the byte enable bits during the data phase, use non-prefetchable read transactions. If these locations are mapped in memory space, use the memory read command and map the target into non-prefetchable (memory-mapped I/O) memory space to utilize non-prefetching behavior.

2.4.4 Read Prefetch Address Boundaries

Tsi350A has internal read address boundaries on read prefetching. When a read transaction reaches one of these aligned address boundaries, Tsi350A stops prefetching data, unless the target signals a target disconnect before the read prefetch boundary is reached. When Tsi350A finishes transferring this read data to the initiator, it returns a target disconnect with the last data transfer, unless the initiator completes the transaction before all prefetched read data is delivered. Any leftover prefetched data is discarded.

Prefetchable read transactions in flow-through mode prefetch to the nearest aligned 4 kB address boundary, or until the initiator de-asserts FRAME_b. **“Delayed Read Completion on Initiator Bus ”** on [page 36](#) describes flow-through mode during read operations.

Table 4 shows the read prefetch address boundaries for read transactions during non-flow-through mode.

Table 4: Read Prefetch Address Boundaries

Type of Transaction	Address Space	Cache Line Size	Prefetch Aligned Address Boundary
Configuration read	--	--	One Dword (no prefetch)
I/O read	--	--	One Dword (no prefetch)
Memory read	Non-prefetchable	--	One Dword (no prefetch)
Memory read	Prefetchable	CLS ≠ 1, 2, 4, 8	16-Dword aligned address boundary
Memory read	Prefetchable	CLS = 1, 2, 4, 8	Cache line address boundary
Memory read line	--	CLS ≠ 1, 2, 4, 8	16-Dword aligned address boundary
Memory read line	--	CLS = 1, 2, 4, 8	Cache line address boundary
Memory read multiple	--	CLS ≠ 1, 2, 4, 8	Queue full
Memory read multiple	--	CLS = 1, 2, 4, 8	Second cache line boundary

2.4.5 Delayed Read Requests

Tsi350A treats all read transactions as delayed read transactions, which means that the read request from the initiator is posted into a delayed transaction queue. Read data from the target is placed in the read data queue and is transferred to the initiator when the initiator repeats the read transaction.

When Tsi350A accepts a delayed read request, it first samples the read address, read bus command, and address parity. When IRDY_b is asserted, Tsi350A then samples the byte enable bits for the first data phase. This information is entered into the delayed transaction queue. Tsi350A terminates the transaction by signaling a target retry to the initiator. Upon reception of the target retry, the initiator is required to continue to repeat the same read transaction until at least one data transfer is completed, or until a target response other than target retry (target abort, or master abort) is received.

2.4.5.1 Delayed Read Completion with Target

When the delayed read request reaches the head of the delayed transaction queue, and all previously queued posted write transactions have been delivered, Tsi350A arbitrates for the target bus and initiates the read transaction, using the exact read address and read command captured from the initiator during the initial delayed read request. If the read transaction is a non-prefetchable read, Tsi350A drives the captured byte enable bits during the next cycle. If the transaction is a prefetchable read transaction, it drives the captured byte enables for first data phase and drives all byte enable bits to 0 for all remaining data phases. If Tsi350A receives a target retry in response to the read transaction on the target bus, it continues to repeat the read transaction until at least one data transfer is completed, or until an error condition is encountered. If the transaction is terminated via normal master termination or target disconnect after at least one data transfer has been completed, Tsi350A does not initiate any further attempts to read more data.

If Tsi350A is unable to obtain read data from the target after 2^{24} attempts, Tsi350A ceases further read attempts and returns a target abort to the initiator. The delayed transaction is removed from the delayed transaction queue. Tsi350A also asserts P_SERR_b if the primary SERR_b enable bit is set in the command register.

Once Tsi350A receives DEVSEL_b and TRDY_b from the target, it transfers the data read to the opposite direction read data queue, pointing toward the opposite interface, before terminating the transaction. For example, read data in response to a downstream read transaction initiated on the primary bus is placed in the upstream read data queue. Tsi350A can accept 1 Dword of read data each PCI clock cycle; that is, no master wait states are inserted. The number of Dwords transferred during a delayed read transaction depends on the conditions given in [Table 4 on page 35](#) (assuming no disconnect is received from the target).

2.4.5.2 Delayed Read Completion on Initiator Bus

When the transaction has been completed on the target bus, and the delayed read data is at the head of the read data queue, and all ordering constraints with posted write transactions have been satisfied, Tsi350A transfers the data to the initiator when the initiator repeats the transaction. For memory read transactions, Tsi350A aliases the memory read, memory read line, and memory read multiple bus commands when matching the bus command of the transaction to the bus command in the delayed transaction queue. Tsi350A returns a target disconnect along with the transfer of the last Dword of read data to the initiator. If the initiator terminates the transaction before all read data has been transferred, the remaining read data left in data buffers is discarded.

When the master repeats the transaction and starts transferring prefetchable read data from Tsi350A data buffers while the read transaction on the target bus is still in progress and before a read boundary is reached on the target bus, the read transaction starts operating in flow-through mode. Because data is flowing through the data buffers from the target to the initiator, long read bursts can then be sustained. In this case, the read transaction is allowed to continue until the initiator terminates the transaction, or until an aligned 4 kB address boundary is reached, or until the buffer fills, whichever comes first. When the buffer empties, Tsi350A reflects the stalled condition to the initiator by de-asserting TRDY_b until more read data is available; otherwise, Tsi350A does not insert any target wait states. When the initiator terminates the transaction, the de-assertion of FRAME_b on the initiator bus is forwarded to the target bus. Any remaining read data is discarded.

Tsi350A implements a discard timer that starts counting when the delayed read completion is at the head of the delayed transaction queue, and the read data is at the head of the read data queue. The initial value of this timer can be set to one of two values, selectable through both the primary and secondary master time-out value bits in the bridge control register. If the initiator does not repeat the read transaction before the discard timer expires Tsi350A discards the read transaction and the read data from its queues. Tsi350A also conditionally asserts P_SERR_b.

Tsi350A has the capability to post multiple delayed read requests, up to a maximum of three in each direction. If an initiator starts a read transaction that matches the address and read command of a read transaction that is already queued, the current read command is not posted as it is already contained in the delayed transaction queue.

2.5 Configuration Transactions

Configuration transactions are used to initialize a PCI system. Every PCI device has a configuration space that is accessed by configuration commands. All Tsi350A registers are accessible in configuration space only.

In addition to accepting configuration transactions for initialization of its own configuration space, Tsi350A also forwards configuration transactions for device initialization in hierarchical PCI systems, as well as for special cycle generation.

To support hierarchical PCI bus systems, two types of configuration transactions are specified: Type 0 and Type 1.

Type 0 configuration transactions are issued when the intended target resides on the same PCI bus as the initiator. A Type 0 configuration transaction is identified by the configuration command and the lowest 2 bits of the address set to 00b.

Type 1 configuration transactions are issued when the intended target resides on another PCI bus, or when a special cycle is to be generated on another PCI bus. A Type 1 configuration command is identified by the configuration command and the lowest 2 address bits set to 01b.

Figure 4 and Figure 5 show the address formats for Type 0 and Type 1 configuration transactions.

Figure 4: Type 0 Configuration Transaction

31	11	10	8	7	2	1	0
Reserved				Function number	Register number	0	0

Figure 5: Type 1 Configuration Transaction

31	24	23	16	15	11	10	8	7	2	1	0
Reserved		Bus number			Device number		Function number	Register number	0	1	

The Register Number field appears in both Type 0 and Type 1 formats and addresses the configuration register to be accessed. The Function Number appears in both Type 0 and Type 1 formats and indicates the function within a multifunction device being accessed. For single function devices, this value is not decoded. Type 1 configuration transaction addresses also include a 5-bit field designating the device number that identifies the device on the target PCI bus that is to be accessed. In addition, the bus number in Type 1 transactions specifies the PCI bus to which the transaction is targeted.

2.5.1 Type 0 Access to Tsi350A

Tsi350A configuration space is accessed by a Type 0 configuration transaction on the primary interface. Tsi350A configuration space cannot be accessed from the secondary bus. Tsi350A responds to a Type 0 configuration transaction by asserting P_DEVSEL_b when the following conditions are met during the address phase:

- The bus command is a configuration read or configuration write transaction.
- Low 2 address bits P_AD[1:0] must be 00b.
- Signal P_IDSEL must be asserted.

The function code is ignored because Tsi350A is a single-function device.

Tsi350A limits all configuration accesses to a single Dword data transfer and returns a target disconnect with the first data transfer if additional data phases are requested. Because read transactions to Tsi350A configuration space do not have side effects, all bytes in the requested Dword are returned, regardless of the value of the byte enable bits.



Type 0 configuration write and read transactions do not use Tsi350A data buffers; that is, these transactions are completed immediately, regardless of the state of the data buffers.

Tsi350A ignores all Type 0 transactions initiated on the secondary interface.

2.5.2 Type 1 to Type 0 Translation

Type 1 configuration transactions are used specifically for device configuration in a hierarchical PCI bus system. A PCI-to-PCI bridge is the only type of device that should respond to a Type 1 configuration command. Type 1 configuration commands are used when the configuration access is intended for a PCI device that resides on a PCI bus other than the one where the Type 1 transaction is generated.

Tsi350A performs a Type 1 to Type 0 translation when the Type 1 transaction is generated on the primary bus and is intended for a device attached directly to the secondary bus. Tsi350A must convert the configuration command to a Type 0 format so that the secondary bus device can respond to it. Type 1 to Type 0 translations are performed only in the downstream direction; that is, Tsi350A generates a Type 0 transaction only on the secondary bus, and never on the primary bus.

Tsi350A responds to a Type 1 configuration transaction and translates it into a Type 0 transaction on the secondary bus when the following conditions are met during the address phase:

- The lower two address bits on P_AD[1:0] are 01b.
- The bus number in address field P_AD[23:16] is equal to the value in the secondary bus number register in Tsi350A configuration space.

The bus command on P_CBE_b[3:0] is a configuration read or configuration write transaction. When Tsi350A translates the Type 1 transaction to a Type 0 transaction on the secondary interface, it performs the following translations to the address:

- Sets the low two address bits on S_AD[1:0] to 00b.

- Decodes the device number and drives the bit pattern specified in Table 5 on S_AD[31:16] for the purpose of asserting the device’s IDSEL signal.
- Sets S_AD[15:11] to 0.
- Leaves unchanged the function number and register number fields.
- Tsi350A asserts a unique address line based on the device number. These address lines may be used as secondary bus IDSEL signals. The mapping of the address lines depends on the device number in the Type 1 address bits P_AD[15:11], as shown in Table 5.

Table 5 shows the mapping used by the Tsi350A.

Table 5: Device Number to IDSEL S_AD Pin Mapping

Device Number	P_AD[15:11]	Secondary IDSEL S_AD[31:16]	S_AD Bit
0h	00000	0000 0000 0000 0001	16
1h	00001	0000 0000 0000 0010	17
2h	00010	0000 0000 0000 0100	18
3h	00011	0000 0000 0000 1000	19
4h	00100	0000 0000 0001 0000	20
5h	00101	0000 0000 0010 0000	21
6h	00110	0000 0000 0100 0000	22
7h	00111	0000 0000 1000 0000	23
8h	01000	0000 0001 0000 0000	24
9h	01001	0000 0010 0000 0000	25
Ah	01010	0000 0100 0000 0000	26
Bh	01011	0000 1000 0000 0000	27
Ch	01100	0001 0000 0000 0000	28
Dh	01101	0010 0000 0000 0000	29
Eh	01110	0100 0000 0000 0000	30
Fh	01111	1000 0000 0000 0000	31
10h-1Eh	10000-11110	0000 0000 0000 0000	--
1Fh	11111	Generate special cycle (P_AD[7:2] = 00h) 0000 0000 0000 0000 (P_AD[7:2] ≠ 00h)	--

Tsi350A can assert up to 16 unique address lines to be used as IDSEL signals for up to 16 devices on the secondary bus, for device numbers ranging from 0 through 15. Because of electrical loading constraints of the PCI bus, more than 16 IDSEL signals should not be necessary. However, if device numbers greater than 15 are desired, some external method of generating IDSEL lines must be used, and no upper address bits are then asserted. The configuration transaction is still translated and passed from the primary bus to the secondary bus. If no IDSEL pin is asserted to a secondary device, the transaction ends in a master abort.



Tsi350A forwards Type 1 to Type 0 configuration read or write transactions as delayed transactions. Type 1 to Type 0 configuration read or write transactions are limited to a single 32-bit data transfer.

2.5.3 Type 1 to Type 1 Forwarding

Type 1 to Type 1 transaction forwarding provides a hierarchical configuration mechanism when two or more levels of PCI-to-PCI bridges are used.

When Tsi350A detects a Type 1 configuration transaction intended for a PCI bus downstream from the secondary bus, Tsi350A forwards the transaction unchanged to the secondary bus. Ultimately, this transaction is translated to a Type 0 configuration command or to a special cycle transaction by a downstream PCI-to-PCI bridge. Downstream Type 1 to Type 1 forwarding occurs when the following conditions are met during the address phase:

- The low 2 address bits are equal to 01b.
- The bus number falls in the range defined by the lower limit (exclusive) in the secondary bus number register and the upper limit (inclusive) in the subordinate bus number register.
- The bus command is a configuration read or write transaction.

Tsi350A also supports Type 1 to Type 1 forwarding of configuration write transactions upstream to support upstream special cycle generation. A Type 1 configuration command is forwarded upstream when the following conditions are met:

- The lower 2 address bits are equal to 01b.
- The bus number falls outside the range defined by the lower limit (inclusive) in the secondary bus number register and the upper limit (inclusive) in the subordinate bus number register.
- The device number in address bits AD[15:11] is equal to 11111b.
- The function number in address bits AD[10:8] is equal to 111b.
- The bus command is a configuration write transaction.



Tsi350A forwards Type 1 to Type 1 configuration write transactions as delayed transactions. Type 1 to Type 1 configuration write transactions are limited to a single data transfer.

2.5.3.1 Special Cycles

The Type 1 configuration mechanism is used to generate special cycle transactions in hierarchical PCI systems. Special cycle transactions are ignored by a PCI-to-PCI bridge acting as a target and are not forwarded across the bridge. Special cycle transactions can be generated from Type 1 configuration write transactions in either the upstream or the downstream direction. Tsi350A initiates a special cycle on the target bus when a Type 1 configuration write transaction is detected on the initiating bus and the following conditions are met during the address phase:

- The low 2 address bits on AD[1:0] are equal to 01b.
- The device number in address bits AD[15:11] is equal to 11111b.
- The function number in address bits AD[10:8] is equal to 111b.
- The register number in address bits AD[7:2] is equal to 000000b.

- The bus number is equal to the value in the secondary bus number register in configuration space for downstream forwarding or equal to the value in the primary bus number register in configuration space for upstream forwarding.
- The bus command on C/BE_b is a configuration write command.

When Tsi350A initiates the transaction on the target interface, the bus command is changed from configuration write to special cycle. The address and data are forwarded unchanged. Devices that use special cycles ignore the address and decode only the bus command. The data phase contains the special cycle message. The transaction is forwarded as a delayed transaction, but in this case the target response is not forwarded back (because special cycles result in a master abort). Once the transaction is completed on the target bus, through detection of the master abort condition, Tsi350A responds with TRDY_b to the next attempt of the configuration transaction from the initiator. If more than one data transfer is requested, Tsi350A responds with a target disconnect operation during the first data phase.

2.6 Transaction Termination

This section describes how Tsi350A returns transaction termination conditions back to the initiator.

The initiator can terminate transactions with one of the following types of termination:

- **Normal Termination:** Normal termination occurs when the initiator de-asserts FRAME_b at the beginning of the last data phase, and de-asserts IRDY_b at the end of the last data phase in conjunction with either TRDY_b or STOP_b assertion from the target.
- **Master Abort:** A master abort occurs when no target response is detected. When the initiator does not detect a DEVSEL_b from the target within five clock cycles after asserting FRAME_b, the initiator terminates the transaction with a master abort. If FRAME_b is still asserted, the initiator de-asserts FRAME_b on the next cycle, and then de-asserts IRDY_b on the following cycle. IRDY_b must be asserted in the same cycle in which FRAME_b de-asserts. If FRAME_b is already de-asserted, IRDY_b can be de-asserted on the next clock cycle following detection of the master abort condition.

The target can terminate transactions with one of the following types of termination:

- **Normal termination:** TRDY_b and DEVSEL_b asserted in conjunction with FRAME_b de-asserted and IRDY_b asserted.
- **Target retry:** STOP_b and DEVSEL_b asserted without TRDY_b during the first data phase. No data transfers occur during the transaction. This transaction must be repeated.
- **Target disconnect with data transfer:** STOP_b and DEVSEL_b asserted with TRDY_b. Signals that this is the last data transfer of the transaction.
- **Target disconnect without data transfer:** STOP_b and DEVSEL_b asserted without TRDY_b after previous data transfers have been made. Indicates that no more data transfers will be made during this transaction.
- **Target abort:** STOP_b asserted without DEVSEL_b and without TRDY_b. Indicates that the target will never be able to complete this transaction. DEVSEL_b must be asserted for at least one cycle during the transaction before the target abort is signaled.

2.6.1 Master Termination Initiated by Tsi350A

Tsi350A, as an initiator, uses normal termination if DEVSEL_b is returned by the target within five clock cycles of Tsi350A's assertion of FRAME_b on the target bus. As an initiator, Tsi350A terminates a transaction when the following conditions are met:

- During a delayed write transaction, a single Dword is delivered.
- During a non-prefetchable read transaction, a single Dword is transferred from the target.
- During a prefetchable read transaction, a prefetch boundary is reached.
- For a posted write transaction, all write data for the transaction is transferred from Tsi350A data buffers to the target.
- For a burst transfer, with the exception of memory write and invalidate transactions, the master latency timer expires and Tsi350A's bus grant is de-asserted.
- The target terminates the transaction with a retry, disconnect, or target abort.

If Tsi350A is delivering posted write data when it terminates the transaction because the master latency timer expires, it initiates another transaction to deliver the remaining write data. The address of the transaction is updated to reflect the address of the current Dword to be delivered. If Tsi350A is prefetching read data when it terminates the transaction because the master latency timer expires, it does not repeat the transaction to obtain more data.

2.6.2 Master Abort Received by Tsi350A

If Tsi350A initiates a transaction on the target bus and does not detect DEVSEL_b returned by the target within five clock cycles of Tsi350A's assertion of FRAME_b, Tsi350A terminates the transaction with a master abort. Tsi350A sets the received master abort bit in the status register corresponding to the target bus.

For delayed read and write transactions, when the master abort mode bit in the bridge control register is 0, Tsi350A returns TRDY_b on the initiator bus and, for read transactions, returns FFFF_FFFFh as data.

When the master abort mode bit is 1, Tsi350A returns target abort on the initiator bus. Tsi350A also sets the signaled target abort bit in the register corresponding to the initiator bus.

When a master abort is received in response to a posted write transaction, Tsi350A discards the posted write data and makes no more attempts to deliver the data. Tsi350A sets the received master abort bit in the status register when the master abort is received on the primary bus, or it sets the received master abort bit in the secondary status register when the master abort is received on the secondary interface. When a master abort is detected in response to a posted write transaction, and the master abort mode bit is set, Tsi350A also asserts P_SERR_b. If enabled by the SERR_b enable bit in the command register and if not disabled by the device-specific P_SERR_b disable bit for master abort during posted write transactions (that is, master abort mode = 1, SERR_b enable bit = 1, and P_SERR_b disable bit for master aborts = 0).

2.6.3 Target Termination Received by Tsi350A

When Tsi350A initiates a transaction on the target bus and the target responds with DEVSEL_b, the target can end the transaction with one of the following types of termination:

- Normal termination (upon de-assertion of FRAME_b)
- Target retry
- Target disconnect
- Target abort

Tsi350A handles these terminations in different ways, depending on the type of transaction being performed.

2.6.3.1 Delayed Write Target Termination Response

When Tsi350A initiates a delayed write transaction, the type of target termination received from the target can be passed back to the initiator. Table 6 shows Tsi350A response to each type of target termination that occurs during a delayed write transaction.

Table 6: Tsi350A Response to Delayed Write Transaction

Target Termination	Response
Normal	Return disconnect to initiator with first data transfer only if multiple data phases requested.
Target retry	Return target retry to initiator. Continue write attempts to target.
Target disconnect	Return disconnect to initiator with first data transfer only if multiple data phases requested.
Target abort	Return target abort to initiator. Set received target abort bit in target interface status register. Set signaled target abort bit in initiator interface status register.

Tsi350A repeats a delayed write transaction until one of the following conditions is met:

- Tsi350A completes at least one data transfer
- Tsi350A receives a master abort.
- Tsi350A receives a target abort.
- Tsi350A makes 2^{24} write attempts resulting in a response of target retry.

After Tsi350A makes 2^{24} attempts of the same delayed write transaction on the target bus, Tsi350A asserts P_SERR_b if the primary SERR_b enable bit is set in the command register and the implementation-specific P_SERR_b disable bit for this condition is not set in the P_SERR_b event disable register. Tsi350A stops initiating transactions in response to that delayed write transaction. The delayed write request is discarded. Upon a subsequent write transaction attempt by the initiator, Tsi350A returns a target abort. For a description of system error conditions see “[System Error \(SERR_b\) Reporting](#)” on page 66.

2.6.3.2 Posted Write Target Termination Response

When Tsi350A initiates a posted write transaction, the target termination cannot be passed back to the initiator. **Table 7** shows Tsi350A response to each type of target termination that occurs during a posted write transaction.

Table 7: Tsi350A Response to Posted Write Termination

Target Termination	Response
Normal	No additional action.
Target retry	Repeat write transaction to target.
Target disconnect	Initiate write transaction to deliver remaining posted write data.
Target abort	Set received target abort bit in the target interface status register. Assert P_SERR_b if enabled, and set the signaled system error bit in the primary status register.



When a target retry or target disconnect is returned and posted write data associated with that transaction remains in the write buffers, Tsi350A initiates another write transaction to attempt to deliver the rest of the write data. In the case of a target retry, the exact same address will be driven as for the initial write transaction attempt. If a target disconnect is received, the address that is driven on a subsequent write transaction attempt is updated to reflect the address of the current Dword.

If the initial write transaction is a memory write and invalidate transaction, and a partial delivery of write data to the target is performed before a target disconnect is received, Tsi350A uses the memory write command to deliver the rest of the write data because less than a cache line will be transferred in the subsequent write transaction attempt.

After Tsi350A makes 2^{24} write transaction attempts and fails to deliver all the posted write data associated with that transaction, Tsi350A asserts P_SERR_b if the primary SERR_b enable bit is set in the command register and the device-specific P_SERR_b disable bit for this condition is not set in the P_SERR_b event disable register. The write data is discarded. For a discussion of system error conditions, see **“System Error (SERR_b) Reporting”** on page 66.

2.6.3.3 Delayed Read Target Termination Response

When Tsi350A initiates a delayed read transaction, the abnormal target responses can be passed back to the initiator. Other target responses depend on how much data the initiator requests. [Table 8](#) shows Tsi350A response to each type of target termination that occurs during a delayed read transaction.

Table 8: Tsi350A Response to Delayed Read Target Termination

Target Termination	Response
Normal	If prefetchable, target disconnect only if initiator requests more data than read from target. If non-prefetchable, target disconnect on first data phase.
Target retry	Re-initiate read transaction to target.
Target disconnect	If initiator requests more data than read from target, return target disconnect to initiator.
Target abort	Return target abort to initiator. Set received target abort bit in the target interface status register. Set signaled target abort bit in the initiator interface status register.

Tsi350A repeats a delayed read transaction until one of the following conditions is met:

- Tsi350A completes at least one data transfer.
- Tsi350A receives a master abort.
- Tsi350A receives a target abort.
- Tsi350A makes 2^{24} read attempts resulting in a response of target retry.

After Tsi350A makes 2^{24} attempts of the same delayed read transaction on the target bus, Tsi350A asserts P_SERR_b if the primary SERR_b enable bit is set in the command register and the implementation-specific P_SERR_b disable bit for this condition is not set in the P_SERR_b event disable register. Tsi350A stops initiating transactions in response to that delayed read transaction. The delayed read request is discarded. Upon a subsequent read transaction attempt by the initiator, Tsi350A returns a target abort. For a discussion of system error conditions, see [“System Error \(SERR_b\) Reporting”](#) on page 66.

2.6.4 Target Termination Initiated by Tsi350A

Tsi350A can return a target retry, target disconnect, or target abort to an initiator for reasons other than detection of that condition at the target interface.

2.6.4.1 Target Retry

Tsi350A returns a target retry to the initiator when it cannot accept write data or return read data as a result of internal conditions. Tsi350A returns a target retry to an initiator when any of the following conditions is met:

Target retry for delayed write transactions:

- The transaction has already been entered into the delayed transaction queue, but target response has not yet been received.
- Target response has been received but has not progressed to the head of the return queue.
- The delayed transaction queue is full, and the transaction cannot be queued.
- A transaction with the same address and command has been queued.
- A locked sequence is being propagated across Tsi350A, and the write transaction is not a locked transaction.

Target retry for delayed read transactions:

- The transaction is being entered into the delayed transaction queue.
- The read request has already been queued, but read data is not yet available.
- Data has been read from the target, but it is not yet at the head of the read data queue, or a posted write transaction precedes it.
- The delayed transaction queue is full, and the transaction cannot be queued.
- A delayed read request with the same address and bus command has already been queued.
- A locked sequence is being propagated across Tsi350A, and the read transaction is not a locked transaction.
- Tsi350A is currently discarding previously prefetched read data.

Target retry for posted write transactions:

- The posted write data buffer does not have enough space for address and at least 8 Dwords of write data.
- A locked sequence is being propagated across Tsi350A, and the write transaction is not a locked transaction.

When a target retry is returned to the initiator of a delayed transaction, the initiator must repeat the transaction with the same address and bus command as well as the data if this is a write transaction, within the time frame specified by the master time-out value; otherwise, the transaction is discarded from Tsi350A buffers.

2.6.4.2 Target Disconnect

Tsi350A returns a target disconnect to an initiator when one of the following conditions is met:

- Tsi350A hits an internal address boundary.
- Tsi350A cannot accept any more write data.
- Tsi350A has no more read data to deliver.

2.6.4.3 Target Abort

Tsi350A returns a target abort to an initiator when one of the following conditions is met:

- Tsi350A is returning a target abort from the intended target.

- Tsi350A is unable to obtain delayed read data from the target or to deliver delayed write data to the target after 2^{24} attempts.

When Tsi350A returns a target abort to the initiator, it sets the signaled target abort bit in the status register corresponding to the initiator interface.

3. Address Decoding

This chapter discusses the following:

- “Overview of Address Decoding” on page 49
- “Address Ranges” on page 49
- “Address Decoding” on page 49
- “Memory Address Decoding” on page 51
- “VGA Support” on page 55

3.1 Overview of Address Decoding

Tsi350A uses three address ranges that control I/O and memory transaction forwarding. These address ranges are defined by base and limit address registers in Tsi350A configuration space. This chapter describes these address ranges, as well as ISA-mode and VGA-addressing support.

3.2 Address Ranges

Tsi350A uses the following address ranges that determine which I/O and memory transactions are forwarded from the primary PCI bus to the secondary PCI bus, and from the secondary PCI bus to the primary PCI bus:

- One 32-bit I/O address range
- One 32-bit memory-mapped I/O (non-prefetchable memory)
- One 64-bit prefetchable memory address range

Transactions falling within these ranges are forwarded downstream from the primary PCI bus to the secondary PCI bus. Transactions falling outside these ranges are forwarded upstream from the secondary PCI bus to the primary PCI bus.

Tsi350A uses a flat address space; that is, it does not perform any address translations. The address space has no “gaps”—addresses that are not marked for downstream forwarding are always forwarded upstream.

3.3 Address Decoding

Tsi350A uses the following mechanisms that are defined in Tsi350A configuration space to specify the I/O address space for downstream and upstream forwarding:

- I/O base and limit address registers
- The ISA enable bit
- The VGA mode bit

- The VGA snoop bit

This section provides information on the I/O address registers and ISA mode. “VGA Mode” on page 55 provides information on the VGA modes.

To enable downstream forwarding of I/O transactions, the I/O enable bit must be set in the command register in Tsi350A configuration space. If the I/O enable bit is not set, all I/O transactions initiated on the primary bus are ignored. To enable upstream forwarding of I/O transactions, the master enable bit must be set in the command register. If the master enable bit is not set, Tsi350A ignores all I/O and memory transactions initiated on the secondary bus. Setting the master enable bit also allows upstream forwarding of memory transactions.



If any Tsi350A configuration state affecting I/O transaction forwarding is changed by a configuration write operation on the primary bus at the same time that I/O transactions are ongoing on the secondary bus, Tsi350A response to the secondary bus I/O transactions is not predictable. Configure the I/O base and limit address registers, ISA enable bit, VGA mode bit, and VGA snoop bit before setting the I/O enable and master enable bits, and change them subsequently only when the primary and secondary PCI buses are idle.

3.3.1 Base and Limit Address Registers

Tsi350A implements one set of I/O base and limit address registers in configuration space that define an I/O address range for downstream forwarding. Tsi350A supports 32-bit I/O addressing, which allows I/O addresses downstream of Tsi350A to be mapped anywhere in a 4 GB I/O address space.

I/O transactions with addresses that fall inside the range defined by the I/O base and limit registers are forwarded downstream from the primary PCI bus to the secondary PCI bus. I/O transactions with addresses that fall outside this range are forwarded upstream from the secondary PCI bus to the primary PCI bus.

The I/O range can be turned off by setting the I/O base address to a value greater than that of the I/O limit address. When the I/O range is turned off, all I/O transactions are forwarded upstream, and no I/O transactions are forwarded downstream.

Tsi350A I/O range has a minimum granularity of 4 kB and is aligned on a 4 kB boundary. The maximum I/O range is 4 GB in size.

The I/O base register consists of an 8-bit field at configuration address 1Ch, and a 16-bit field at address 30h. The top 4 bits of the 8-bit field define bits [15:12] of the I/O base address. The bottom 4 bits read only as 1h to indicate that Tsi350A supports 32-bit I/O addressing. Bits [11:0] of the base address are assumed to be 0, which naturally aligns the base address to a 4 kB boundary.

The 16 bits contained in the I/O base upper 16 bits register at configuration offset 30h define AD[31:16] of the I/O base address. All 16 bits are read/write. After primary bus reset or chip reset, the value of the I/O base address is initialized to 0000 0000h.

The I/O limit register consists of an 8-bit field at configuration offset 1Dh and a 16-bit field at offset 32h. The top 4 bits of the 8-bit field define bits [15:12> of the I/O limit address. The bottom 4 bits read only as 1h to indicate that 32-bit I/O addressing is supported. Bits [11:0> of the limit address are assumed to be FFFh, which naturally aligns the limit address to the top of a 4kB I/O address block. The 16 bits contained in the I/O limit upper 16 bits register at configuration offset 32h define AD[31:16> of the I/O limit address. All 16 bits are read/write. After primary bus reset or chip reset, the value of the I/O limit address is reset to 0000 0FFFh.



The initial states of the I/O base and I/O limit address registers define an I/O range of 0000 0000h to 0000 0FFFh, which is the bottom 4 kB of I/O space. Write these registers with their appropriate values before either setting the I/O enable bit or the master enable bit in the command register in configuration space.

3.3.2 ISA Mode

Tsi350A supports ISA mode by providing an ISA enable bit in the bridge control register in configuration space. ISA mode modifies the response of Tsi350A inside the I/O address range in order to support mapping of I/O space in the presence of an ISA bus in the system. This bit only affects the response of Tsi350A when the transaction falls inside the address range defined by the I/O base and limit address registers, and only when this address also falls inside the first 64 kB of I/O space (address bits [31:16> are 0000h).

When the ISA enable bit is set, Tsi350A does not forward downstream any I/O transactions addressing the top 768 bytes of each aligned 1 kB block. Only those transactions addressing the bottom 256 bytes of an aligned 1 kB block inside the base and limit I/O address range are forwarded downstream. Transactions above the 64 kB I/O address boundary are forwarded as defined by the address range defined by the I/O base and limit registers.

Accordingly, if the ISA enable bit is set, Tsi350A forwards upstream those I/O transactions addressing the top 768 bytes of each aligned 1 kB block within the first 64 kB of I/O space. The master enable bit in the command configuration register must also be set to enable upstream forwarding. All other I/O transactions initiated on the secondary bus are forwarded upstream only if they fall outside the I/O address range.

When the ISA enable bit is set, devices downstream of Tsi350A can have I/O space mapped into the first 256 bytes of each 1 kB chunk below the 64 kB boundary, or anywhere in I/O space above the 64 kB boundary.

3.4 Memory Address Decoding

Tsi350A has three mechanisms for defining memory address ranges for forwarding of memory transactions:

- Memory-mapped I/O base and limit address registers
- Prefetchable memory base and limit address registers
- VGA mode

To enable downstream forwarding of memory transactions, the memory enable bit must be set in the command register in Tsi350A configuration space. To enable upstream forwarding of memory transactions, the master enable bit must be set in the command register. Setting the master enable bit also allows upstream forwarding of I/O transactions.



If any Tsi350A configuration state affecting memory transaction forwarding is changed by configuration write operation on the primary bus at the same time that memory transactions are ongoing on the secondary bus, Tsi350A response to the secondary bus memory transactions is not predictable. Configure the memory-mapped I/O base and limit address registers, prefetchable memory base and limit address registers, and VGA mode bit before setting the memory enable and master enable bits, and change them subsequently only when the primary and secondary PCI buses are idle.

3.4.1 Memory-Mapped I/O Base and Limit Address Registers

Memory-mapped I/O is also referred to as non-prefetchable memory. Memory addresses that cannot automatically be prefetched but that can conditionally prefetch based on command type should be mapped into this space. Read transactions to non-prefetchable space may exhibit side effects; this space may have non-memory-like behavior. Tsi350A prefetches in this space only if the memory read line or memory read multiple commands are used; transactions using the memory read command are limited to a single data transfer.

The memory-mapped I/O base address and memory-mapped I/O limit address registers define an address range that Tsi350A uses to determine when to forward memory commands. Tsi350A forwards a memory transaction from the primary to the secondary interface if the transaction address falls within the memory-mapped I/O address range. Tsi350A ignores memory transactions initiated on the secondary interface that fall into this address range. Any transactions that fall outside this address range are ignored on the primary interface and are forwarded upstream from the secondary interface (provided that they do not fall into the prefetchable memory range or are not forwarded downstream by the VGA mechanism).

The memory-mapped I/O range supports 32-bit addressing only. The *PCI-to-PCI Bridge Architecture Specification* does not provide for 64-bit addressing in the memory-mapped I/O space. The memory-mapped I/O address range has a granularity and alignment of 1 MB. The maximum memory-mapped I/O address range is 4 GB.

The memory-mapped I/O address range is defined by a 16-bit memory-mapped I/O base address register at configuration offset 20h and by a 16-bit memory-mapped I/O limit address register at offset 22h. The top 12 bits of each of these registers correspond to bits [31:20] of the memory address. The low 4 bits are hardwired to 0. The low 20 bits of the memory-mapped I/O base address are assumed to be 0 0000h, which results in a natural alignment to a 1 MB boundary. The low 20 bits of the memory-mapped I/O limit address are assumed to be F FFFFh, which results in an alignment to the top of a 1 MB block.

To turn off the memory-mapped I/O address range, write the memory-mapped I/O base address register with a value greater than that of the memory-mapped I/O limit address register.



The initial state of the memory-mapped I/O base address register is 0000 0000h. The initial state of the memory-mapped I/O limit address register is 000F FFFFh. Note that the initial states of these registers define a memory-mapped I/O range at the bottom 1 MB block of memory. Write these registers with their appropriate values before setting either the memory enable bit or the master enable bit in the command register in configuration space.

3.4.2 Prefetchable Memory Base and Limit Address Registers

Locations accessed in the prefetchable memory address range must have true memory-like behavior and must not exhibit side effects when read. This means that extra reads to a prefetchable memory location must have no side effects. Tsi350A prefetches for all types of memory read commands in this address space.

The prefetchable memory base address and prefetchable memory limit address registers define an address range that Tsi350A uses to determine when to forward memory commands. Tsi350A forwards a memory transaction from the primary to the secondary interface if the transaction address falls within the prefetchable memory address range. Tsi350A ignores memory transactions initiated on the secondary interface that fall into this address range. Tsi350A does not respond to any transactions that fall outside this address range on the primary interface and forwards those transactions upstream from the secondary interface (provided that they do not fall into the memory-mapped I/O range or are not forwarded by the VGA mechanism).

The prefetchable memory range supports 64-bit addressing and provides additional registers to define the upper 32 bits of the memory address range, the prefetchable memory base address upper 32 bits register, and the prefetchable memory limit address upper 32 bits register. For address comparison, a single address cycle (32-bit address) prefetchable memory transaction is treated like a 64-bit address transaction where the upper 32 bits of the address are equal to 0. This upper 32-bit value of 0 is compared to the prefetchable memory base address upper 32 bits register and the prefetchable memory limit address upper 32 bits register. The prefetchable memory base address upper 32 bits register must be 0 in order to pass any single address cycle transactions downstream. **“Prefetchable Memory 64-Bit Addressing Registers” on page 54** describes 64-bit addressing support.

The prefetchable memory address range has a granularity and alignment of 1 MB. The maximum memory address range is 4 GB when 32-bit addressing is used, and above 4 GB when 64-bit addressing is used. The prefetchable memory address range is defined by a 16-bit prefetchable memory base address register at configuration offset 24h and by a 16-bit prefetchable memory limit address register at offset 28h. The top 12 bits of each of these registers correspond to bits [31:20] of the memory address. The low 4 bits are hardwired to 1h, indicating 64-bit address support. The low 20 bits of the prefetchable memory base address are assumed to be 0 0000h, which results in a natural alignment to a 1 MB boundary. The low 20 bits of the prefetchable memory limit address are assumed to be F FFFFh, which results in an alignment to the top of a 1 MB block.



The initial state of the prefetchable memory base address register is 0000 0000h. The initial state of the prefetchable memory limit address register is 000F FFFFh. Note that the initial states of these registers define a prefetchable memory range at the bottom 1 MB block of memory. Write these registers with their appropriate values before setting either the memory enable bit or the master enable bit in the command register in configuration space.

To turn off the prefetchable memory address range, write the prefetchable memory base address register with a value greater than that of the prefetchable memory limit address register. The entire base value must be greater than the entire limit value, meaning that the upper 32 bits must be considered. Therefore, to disable the address range, the upper 32 bits registers can both be set to the same value, while the lower base register is set greater than the lower limit register; otherwise, the upper 32-bit base must be greater than the upper 32-bit limit.

3.4.3 Prefetchable Memory 64-Bit Addressing Registers

Tsi350A supports 64-bit memory address decoding for forwarding of dual address memory transactions. The dual address cycle is used to support 64-bit addressing. The first address phase of a dual address transaction contains the low 32 address bits, and the second address phase contains the high 32 address bits. During a dual address cycle transaction, the upper 32 bits must never be 0 - use the single address cycle commands for transactions addressing the first 4 GB of memory space.

Tsi350A implements the prefetchable memory base address upper 32 bits register and the prefetchable memory limit address upper 32 bits register to define a prefetchable memory address range greater than 4 GB. The prefetchable address space can then be defined in three different ways:

- Residing entirely in the first 4 GB of memory
- Residing entirely above the first 4 GB of memory
- Crossing the first 4 GB memory boundary

If the prefetchable memory space on the secondary interface resides entirely in the first 4 GB of memory, both upper 32 bits registers must be set to 0. Tsi350A ignores all dual address cycle transactions initiated on the primary interface and forwards all dual address transactions initiated on the secondary interface upstream.

If the secondary interface prefetchable memory space resides entirely above the first 4 GB of memory, both the prefetchable memory base address upper 32 bits register and the prefetchable memory limit address upper 32 bits register must be initialized to nonzero values. Tsi350A ignores all single address memory transactions initiated on the primary interface and forwards all single address memory transactions initiated on the secondary interface upstream (unless they fall within the memory-mapped I/O or VGA memory range). A dual address memory transaction is forwarded downstream from the primary interface if it falls within the address range defined by the prefetchable memory base address, prefetchable memory base address upper 32 bits, prefetchable memory limit address, and prefetchable memory limit address upper 32 bits registers. If the dual address transaction initiated on the secondary interface falls outside this address range, it is forwarded upstream to the primary interface. Tsi350A does not respond to a dual address transaction initiated on the primary interface that falls outside this address range, or to a dual address transaction initiated on the secondary interface that falls within the address range.

If the secondary interface prefetchable memory space straddles the first 4 GB address boundary, the prefetchable memory base address upper 32 bits register is set to 0, while the prefetchable memory limit address upper 32 bits register is initialized to a nonzero value. Single address cycle memory transactions are compared to the prefetchable memory base address register only. A transaction initiated on the primary interface is forwarded downstream if the address is greater than or equal to the base address. A transaction initiated on the secondary interface is forwarded upstream if the address is less than the base address. Dual address transactions are compared to the prefetchable memory limit address and the prefetchable memory limit address upper 32 bits registers. If the address of the dual address transaction is less than or equal to the limit, the transaction is forwarded downstream from the primary interface and is ignored on the secondary interface. If the address of the dual address transaction is greater than this limit, the transaction is ignored on the primary interface and is forwarded upstream from the secondary interface.

The prefetchable memory base address upper 32 bits register is located at configuration Dword offset 28h, and the prefetchable memory limit address upper 32 bits register is located at configuration Dword offset 2Ch. Both registers are reset to 0.

3.5 VGA Support

Tsi350A provides two modes for VGA support:

- VGA mode, supporting VGA-compatible addressing
- VGA snoop mode, supporting VGA palette forwarding

3.5.1 VGA Mode

When a VGA-compatible device exists downstream from Tsi350A, set the VGA mode bit in the bridge control register in configuration space to enable VGA mode. When Tsi350A is operating in VGA mode, it forwards downstream those transactions addressing the VGA frame buffer memory and VGA I/O registers, regardless of the values of Tsi350A base and limit address registers. Tsi350A ignores transactions initiated on the secondary interface addressing these locations.

The VGA frame buffer consists of the following memory address range: 000A 0000h—000B FFFFh

Read transactions to frame buffer memory are treated as non-prefetchable. Tsi350A requests only a single data transfer from the target, and read byte enable bits are forwarded to the target bus.

The VGA I/O addresses consist of the following I/O addresses:

- 3B0h–3BBh
- 3C0h–3DFh

These I/O addresses are aliased every 1 kB throughout the first 64 kB of I/O space. This means that address bits [15:10] are not decoded and can be any value, while address bits [31:16] must be all zero.

VGA BIOS addresses starting at C0000h are not decoded in VGA mode.

3.5.2 VGA Snoop Mode

Tsi350A provides VGA snoop mode, allowing for VGA palette write transactions to be forwarded downstream. This mode is used when a graphics device downstream from Tsi350A needs to snoop or respond to VGA palette write transactions. To enable the mode, set the VGA snoop bit in the command register in configuration space.



Tsi350A claims VGA palette write transactions by asserting DEVSEL_b in VGA snoop mode.

When the VGA snoop bit is set, Tsi350A forwards downstream transactions with the following I/O addresses:

- 3C6h
- 3C8h
- 3C9h.I



These addresses are also forwarded as part of the VGA compatibility mode previously described. Again, address bits <15:10> are not decoded, while address bits <31:16> must be equal to 0, which means that these addresses are aliased every 1 kB throughout the first 64 kB of I/O space.

If both the VGA mode bit and the VGA snoop bit are set, Tsi350A behaves in the same way as if only the VGA mode bit were set

4. Transaction Ordering

This chapter discusses the following:

- “Overview of Transaction Ordering” on page 57
- “Transaction Governed by Ordering Rules” on page 57
- “General Ordering Guidelines” on page 58

4.1 Overview of Transaction Ordering

To maintain data coherency and consistency, Tsi350A complies with the ordering rules set forth in the *PCI Local Bus Specification, Revision 2.3*, for transactions crossing the bridge.

This chapter describes the ordering rules that control transaction forwarding across Tsi350A. For a more detailed discussion of transaction ordering, see Appendix E of the *PCI Local Bus Specification, Revision 2.3*.

4.2 Transaction Governed by Ordering Rules

Ordering relationships are established for the following classes of transactions crossing Tsi350A:

- **Posted write transactions** - comprised of memory write and memory write and invalidate transactions. Posted write transactions complete at the source before they complete at the destination; that is, data is written into intermediate data buffers before it reaches the target.
- **Delayed write request transactions** - comprised of I/O write and configuration write transactions. Delayed write requests are terminated by target retry on the initiator bus and are queued in the delayed transaction queue. A delayed write transaction must complete on the target bus before it completes on the initiator bus.
- **Delayed write completion transactions** - also comprised of I/O write and configuration write transactions. Delayed write completion transactions have been completed on the target bus, and the target response is queued in Tsi350A buffers. A delayed write completion transaction proceeds in the direction opposite that of the original delayed write request; that is, a delayed write completion transaction proceeds from the target bus to the initiator bus.
- **Delayed read request transactions** - comprised of all memory read, I/O read, and configuration read transactions. Delayed read requests are terminated by target retry on the initiator bus and are queued in the delayed transaction queue.

- **Delayed read completion transactions** - comprised of all memory read, I/O read, and configuration read transactions. Delayed read completion transactions have been completed on the target bus, and the read data has been queued in Tsi350A read data buffers. A delayed read completion transaction proceeds in the direction opposite that of the original delayed read request; that is, a delayed read completion transaction proceeds from the target bus to the initiator bus.

Tsi350A does not combine or merge write transactions:

- Tsi350A does not combine separate write transactions into a single write transaction—this optimization is best implemented in the originating master.
- Tsi350A does not merge bytes on separate masked write transactions to the same Dword address—this optimization is also best implemented in the originating master.
- Tsi350A does not collapse sequential write transactions to the same address into a single write transaction—the [PCI Local Bus Specification](#) does not permit this combining of transactions.

4.3 General Ordering Guidelines

Independent transactions on the primary and secondary buses have a relationship only when those transactions cross Tsi350A.

The following general ordering guidelines govern transactions crossing Tsi350A:

- The ordering relationship of a transaction with respect to other transactions is determined when the transaction completes, that is, when a transaction ends with a termination other than target retry.
- Requests terminated with target retry can be accepted and completed in any order with respect to other transactions that have been terminated with target retry. If the order of completion of delayed requests is important, the initiator should not start a second delayed transaction until the first one has been completed. If more than one delayed transaction is initiated, the initiator should repeat all the delayed transaction requests, using some fairness algorithm. Repeating a delayed transaction cannot be contingent on completion of another delayed transaction; otherwise, a deadlock can occur.
- Write transactions flowing in one direction have no ordering requirements with respect to write transactions flowing in the other direction. Tsi350A can accept posted write transactions on both interfaces at the same time, as well as initiate posted write transactions on both interfaces at the same time.
- The acceptance of a posted memory write transaction as a target can never be contingent on the completion of a non-locked, non-posted transaction as a master. This is true of Tsi350A and must be true of other bus agents; otherwise, a deadlock can occur.
- Tsi350A accepts posted write transactions, regardless of the state of completion of any delayed transactions being forwarded across Tsi350A.

4.3.1 Ordering Rules

Table 9 shows the ordering relationships of all the transactions and refers by number to the ordering rules that follow.



The superscript accompanying some of the table entries refers to any applicable ordering rule listed in this section. Many entries are not governed by these ordering rules; therefore, the implementation can choose whether the transactions pass each other.

The entries without superscripts reflect Tsi350A's implementation choices.

Table 9: Summary of Transaction Ordering

Bus Operation	Can Row Pass Column?				
	Posted Write	Delayed Read Request	Delayed Write Request	Delayed Read Completion	Delayed Write Completion
Posted Write	No ¹	Yes ⁵	Yes ⁵	Yes ⁵	Yes ⁵
Delayed Read Request	No ²	No	No	Yes	Yes
Delayed Write Request	No ⁴	No	No	Yes	Yes
Delayed Read Completion	No ³	Yes	Yes	No	No
Delayed Write Completion	Yes	Yes	Yes	No	No

The following ordering rules describe the transaction relationships. Each ordering rule is followed by an explanation. These ordering rules apply to posted write transactions, delayed write and read requests, and delayed write and read completion transactions crossing Tsi350A in the same direction. Note that delayed completion transactions cross Tsi350A in the direction opposite that of the corresponding delayed requests.

1. Posted write transactions must complete on the target bus in the order in which they were received on the initiator bus. The subsequent posted write transaction can be setting a flag that covers the data in the first posted write transaction; if the second transaction were to complete before the first transaction, a device checking the flag could subsequently consume stale data.
2. A delayed read request traveling in the same direction, as a previously queued posted write transaction must push the posted write data ahead of it. The posted write transaction must complete on the target bus before the delayed read request can be attempted on the target bus. The read transaction can be to the same location as the write data, so if the read transaction were to pass the write transaction, it would return stale data.

3. A delayed read completion must “pull” ahead of previously queued posted write data traveling in the same direction. In this case, the read data is traveling in the same direction as the write data and the initiator of the read transaction is on the same side of Tsi350A as the target of the write transaction. The posted write transaction must complete to the target before the read data is returned to the initiator. The read transaction can be to a status register of the initiator of the posted write data and therefore should not complete until the write transaction is complete.
4. Delayed write requests cannot pass previously queued posted write data. As in the case of posted memory write transactions, the delayed write transaction can be setting a flag that covers the data in the posted write transaction; if the delayed write request were to complete before the earlier posted write transaction, a device checking the flag could subsequently consume stale data.
5. Posted write transactions must be given opportunities to pass delayed read and write requests and completions. Otherwise, deadlocks may occur when bridges that support delayed transactions are used in the same system with bridges that do not support-delayed transactions. A fairness algorithm is used to arbitrate between the posted write queue and the delayed transaction queue.

5. Error Handling

This chapter discusses the following:

- “Overview of Error Handling” on page 61
 - “Address Parity Errors” on page 61
 - “Data Parity Errors” on page 62
 - “System Error (SERR_b) Reporting” on page 66
-

5.1 Overview of Error Handling

Tsi350A checks, forwards, and generates parity on both the primary and secondary interfaces. To maintain transparency, Tsi350A always tries to forward the existing parity condition on one bus to the other bus, along with address and data. Tsi350A always attempts to be transparent when reporting errors, but this is not always possible, given the presence of posted data and delayed transactions.

To support error reporting on the PCI bus, Tsi350A implements the following:

- PERR_b and SERR_b signals on both the primary and secondary interfaces.
- Primary status and secondary status registers.
- The device-specific P_SERR_b event disable register.
- The device-specific P_SERR_b status register.

This chapter provides detailed information about how Tsi350A handles errors. It also describes error status reporting and error operation disabling.

5.2 Address Parity Errors

Tsi350A checks address parity for all transactions on both buses, for all address and all bus commands.

When Tsi350A detects an address parity error on the primary interface, the following events occur:

- If the parity error response bit is set in the command register, Tsi350A does not claim the transaction with P_DEVSEL_b; this may allow the transaction to terminate in a master abort. If the parity error response bit is not set, Tsi350A proceeds normally and accepts the transaction if it is directed to or across Tsi350A.
- Tsi350A sets the detected parity error bit in the status register.
- Tsi350A asserts P_SERR_b and sets the signaled system error bit in the status register, if both of the following conditions are met:
 - The SERR_b enable bit is set in the command register.
 - The parity error response bit is set in the command register

When Tsi350A detects an address parity error on the secondary interface, the following events occur:

- If the parity error response bit is set in the bridge control register, Tsi350A does not claim the transaction with S_DEVSEL_b; this may allow the transaction to terminate in a master abort. If the parity error response bit is not set, Tsi350A proceeds normally and accepts the transaction if it is directed to or across Tsi350A.
- Tsi350A sets the detected parity error bit in the secondary status register.
- Tsi350A asserts P_SERR_b and sets the signaled system error bit in the status register, if both of the following conditions are met:
 - The SERR_b enable bit is set in the command register.
 - The parity error response bit is set in the bridge control register.

5.3 Data Parity Errors

When forwarding transactions, Tsi350A attempts to pass the data parity condition from one interface to the other unchanged, whenever possible, to allow the master and target devices to handle the error condition.

The following sections describe, for each type of transaction, the sequence of events that occurs when a parity error is detected and the way in which the parity condition is forwarded across Tsi350A.

5.3.1 Configuration Write Transactions to Tsi350A Configuration Space

When Tsi350A detects a data parity error during a Type 0 configuration write transaction to Tsi350A configuration space, the following events occur:

- If the parity error response bit is set in the command register, Tsi350A asserts P_TRDY_b and writes the data to the configuration register. Tsi350A also asserts P_PERR_b.
- If the parity error response bit is not set, Tsi350A does not assert P_PERR_b.

Tsi350A sets the detected parity error bit in the status register, regardless of the state of the parity error response bit.

5.3.2 Read Transactions

When Tsi350A detects a parity error during a read transaction, the target drives data and data parity, and the initiator checks parity and conditionally asserts PERR_b.

For downstream transactions, when Tsi350A detects a read data parity error on the secondary bus, the following events occur:

- Tsi350A asserts S_PERR_b two cycles following the data transfer, if the secondary interface parity error response bit is set in the bridge control register.
- Tsi350A sets the detected parity error bit in the secondary status register.
- Tsi350A sets the data parity detected bit in the secondary status register, if the secondary interface parity error response bit is set in the bridge control register.

- Tsi350A forwards the bad parity with the data back to the initiator on the primary bus. If the data with the bad parity is prefetched and is not read by the initiator on the primary bus, the data is discarded and the data with bad parity is not returned to the initiator.
- Tsi350A completes the transaction normally.

For upstream transactions, when Tsi350A detects a read data parity error on the primary bus, the following events occur:

- Tsi350A asserts P_PERR_b two cycles following the data transfer, if the primary interface parity error response bit is set in the command register
- Tsi350A sets the detected parity error bit in the primary status register.
- Tsi350A sets the data parity detected bit in the primary status register, if the primary interface parity error response bit is set in the command register.
- Tsi350A forwards the bad parity with the data back to the initiator on the secondary bus. If the data with the bad parity is prefetched and is not read by the initiator on the secondary bus, the data is discarded and the data with bad parity is not returned to the initiator.
- Tsi350A completes the transaction normally.

Tsi350A returns to the initiator the data and parity that was received from the target. When the initiator detects a parity error on this read data and is enabled to report it, the initiator asserts PERR_b two cycles after the data transfer occurs. It is assumed that the initiator takes responsibility for handling a parity error condition; therefore, when Tsi350A detects PERR_b asserted while returning read data to the initiator, Tsi350A does not take any further action and completes the transaction normally.

5.3.3 Delayed Write Transactions

When Tsi350A detects a data parity error during a delayed write transaction, the initiator drives data and data parity, and the target checks parity and conditionally asserts PERR_b.

For delayed write transactions, a parity error can occur at the following times:

- During the original delayed write request transaction
- When the initiator repeats the delayed write request transaction
- When Tsi350A completes the delayed write transaction to the target

When a delayed write transaction is normally queued, the address, command, address parity, data, byte enable bits, and data parity are all captured and a target retry is returned to the initiator. When Tsi350A detects a parity error on the write data for the initial delayed write request transaction, the following events occur:

- If the parity error response bit corresponding to the initiator bus is set, Tsi350A asserts TRDY_b to the initiator and the transaction is not queued. If multiple data phases are requested, STOP_b is also asserted to cause a target disconnect. Two cycles after the data transfer, Tsi350A also asserts PERR_b. If the parity error response bit is not set, Tsi350A returns a target retry and queues the transaction as usual. Signal PERR_b is not asserted. In this case, the initiator repeats the transaction.

- Tsi350A sets the detected parity error bit in the status register corresponding to the initiator bus, regardless of the state of the parity error response bit.



If parity checking is turned off and data parity errors have occurred for queued or subsequent delayed write transactions on the initiator bus, it is possible that the initiator's reattempts of the write transaction may not match the original queued delayed write information contained in the delayed transaction queue. In this case, a master time-out condition may occur, possibly resulting in a system error (P_SERR_b asserted).

For downstream transactions, when Tsi350A is delivering data to the target on the secondary bus and S_PERR_b is asserted by the target, the following events occur:

- Tsi350A sets the secondary interface data parity detected bit in the secondary status register, if the secondary parity error response bit is set in the bridge control register.
- Tsi350A captures the parity error condition to forward it back to the initiator on the primary bus.

Similarly, for upstream transactions, when Tsi350A is delivering data to the target on the primary bus and P_PERR_b is asserted by the target, the following events occur:

- Tsi350A sets the primary interface data parity detected bit in the status register, if the primary parity error response bit is set in the command register.
- Tsi350A captures the parity error condition to forward it back to the initiator on the secondary bus.

A delayed write transaction is completed on the initiator bus when the initiator repeats the write transaction with the same address, command, data, and byte enable bits as the delayed write command that is at the head of the posted data queue. Note that the parity bit is not compared when determining whether the transaction matches those in the delayed transaction queues.

Two cases must be considered:

- When parity error is detected on the initiator bus on a subsequent reattempt of the transaction and was not detected on the target bus.
- When parity error is forwarded back from the target bus.

For downstream delayed write transactions, when the parity error is detected on the initiator bus and Tsi350A has write status to return, the following events occur:

- Tsi350A first asserts P_TRDY_b and then asserts P_PERR_b two cycles later, if the primary interface parity error response bit is set in the command register.
- Tsi350A sets the primary interface parity error detected bit in the status register.
- Because there was not an exact data and parity match, the write status is not returned and the transaction remains in the queue.

Similarly, for upstream delayed write transactions, when the parity error is detected on the initiator bus and Tsi350A has write status to return, the following events occur:

- Tsi350A first asserts S_TRDY_b and then asserts S_PERR_b two cycles later, if the secondary interface parity error response bit is set in the bridge control register.
- Tsi350A sets the secondary interface parity error detected bit in the secondary status register.
- Because there was not an exact data and parity match, the write status is not returned and the transaction remains in the queue.

For downstream transactions, in the case where the parity error is being passed back from the target bus and the parity error condition was not originally detected on the initiator bus, the following events occur:

- Tsi350A asserts P_PERR_b two cycles after the data transfer, if both of the following are true:
 - The primary interface parity error response bit is set in the command register.
 - The secondary interface parity error response bit is set in the bridge control register.
- Tsi350A completes the transaction normally.

For upstream transactions, in the case where the parity error is being passed back from the target bus and the initiator bus, the following events occur:

- Tsi350A asserts S_PERR_b two cycles after the data transfer, if both of the following are true:
 - The primary interface parity error response bit is set in the command register.
 - The secondary interface parity error response bit is set in the bridge control register.
- Tsi350A completes the transaction normally.

5.3.4 Posted Write Transactions

During downstream-posted write transactions, when Tsi350A, responding as a target, detects a data parity error on the initiator (primary) bus, the following events occur:

- Tsi350A asserts P_PERR_b two cycles after the data transfer, if the primary interface parity error response bit is set in the command register.
- Tsi350A sets the primary interface parity error detected bit in the status register.
- Tsi350A captures and forwards the bad parity condition to the secondary bus.
- Tsi350A completes the transaction normally.

Similarly, during upstream posted write transactions, when Tsi350A, responding as a target, detects a data parity error on the initiator (secondary) bus, the following events occur:

- Tsi350A asserts S_PERR_b two cycles after the data transfer, if the secondary interface parity error response bit is set in the bridge control register.
- Tsi350A sets the secondary interface parity error detected bit in the secondary status register.
- Tsi350A captures and forwards the bad parity condition to the primary bus.
- Tsi350A completes the transaction normally.

During downstream write transactions, when a data parity error is reported on the target (secondary) bus by the target's assertion of S_PERR_b, the following events occur:

- Tsi350A sets the data parity detected bit in the secondary status register, if the secondary interface parity error response bit is set in the bridge control register.
- Tsi350A asserts P_SERR_b and sets the signaled system error bit in the status register, if all of the following conditions are met:
 - The SERR_b enable bit is set in the command register.
 - The device-specific P_SERR_b disable bit for posted write parity errors is not set.

- The secondary interface parity error response bit is set in the bridge control register.
- The primary interface parity error response bit is set in the command register.
- Tsi350A did not detect the parity error on the primary (initiator) bus; that is, the parity error was not forwarded from the primary bus.

During upstream write transactions, when a data parity error is reported on the target (primary) bus by the target's assertion of P_PERR_b, the following events occur:

- Tsi350A sets the data parity detected bit in the status register, if the primary interface parity error response bit is set in the command register.
- Tsi350A asserts P_SERR_b and sets the signaled system error bit in the status register, if all of the following conditions are met:
 - The SERR_b enable bit is set in the command register.
 - The secondary interface parity error response bit is set in the bridge control register.
 - The primary interface parity error response bit is set in the command register.
 - Tsi350A did not detect the parity error on the secondary (initiator) bus; that is, the parity error was not forwarded from the secondary bus.

The assertion of P_SERR_b is used to signal the parity error condition in the case where the initiator does not know that the error occurred. Because the data has already been delivered with no errors, there is no other way to signal this information back to the initiator.

If the parity error was forwarded from the initiating bus to the target bus, P_SERR_b is not asserted.

5.4 System Error (SERR_b) Reporting

Tsi350A uses the P_SERR_b signal to report conditionally a number of system error conditions in addition to the special case parity error conditions (see “[Delayed Write Transactions](#)” on page 63).

Whenever the assertion of P_SERR_b is discussed in this document, it is assumed that the following conditions apply:

- For Tsi350A to assert P_SERR_b for any reason, the SERR_b enable bit must be set in the command register.
- Whenever Tsi350A asserts P_SERR_b, Tsi350A must also set the signaled system error bit in the status register.

In compliance with the *PCI-to-PCI Bridge Architecture Specification*, Tsi350A asserts P_SERR_b when it detects the secondary SERR_b input, S_SERR_b, asserted and the SERR_b forward enable bit is set in the bridge control register. In addition, Tsi350A also sets the received system error bit in the secondary status register.

Tsi350A also conditionally asserts P_SERR_b for any of the following reasons:

- Target abort detected during posted write transaction.
- Master abort detected during posted write transaction.
- Posted write data discarded after 2^{24} attempts to deliver (2^{24} target retries received).

- Parity error reported on target bus during posted write transaction (see “Posted Write Transactions” on page 65).
- Delayed write data discarded after 2^{24} attempts to deliver (2^{24} target retries received).
- Delayed read data cannot be transferred from target after 2^{24} attempts (2^{24} target retries received).
- Master time-out on delayed transaction.

The device-specific P_SERR_b status register reports the reason for Tsi350A’s assertion of P_SERR_b.

Most of these events have additional device-specific disable bits in the P_SERR_b event disable register that make it possible to mask out P_SERR_b assertion for specific events. The master time-out condition has a SERR_b enable bit for that event in the bridge control register and therefore does not have a device-specific disable bit.

6. Exclusive Access

This chapter describes the use of the LOCK_b signal to implement exclusive access to a target for transactions that cross Tsi350A. This chapter discusses the following:

- “Concurrent Locks” on page 69
- “Acquiring Exclusive Access Across the Tsi350A” on page 69
- “Ending Exclusive Access” on page 70

6.1 Concurrent Locks

The primary and secondary bus lock mechanisms operate concurrently except when a locked transaction crosses Tsi350A. A primary master can lock a primary target without affecting the status of the lock on the secondary bus, and vice versa. This means that a primary master can lock a primary target at the same time that a secondary master locks a secondary target.

6.2 Acquiring Exclusive Access Across the Tsi350A

For any PCI bus, before acquiring access to the LOCK_b signal and starting a series of locked transactions, the initiator must first check that both of the following conditions are met:

- The PCI bus must be idle.
- The LOCK_b signal must be de-asserted.

The initiator leaves the LOCK_b signal de-asserted during the address phase (only the first address phase of a dual address transaction) and asserts LOCK_b one clock cycle later. Once a data transfer is completed from the target, the target lock has been achieved.

Locked transactions can cross Tsi350A only in the downstream direction, from the primary bus to the secondary bus. When the target resides on another PCI bus, the master must acquire not only the lock on its own PCI bus but also the lock on every bus between its bus and the target’s bus. When Tsi350A detects, on the primary bus, an initial locked transaction intended for a target on the secondary bus, Tsi350A samples the address, transaction type, byte enable bits, and parity. It also samples the lock signal.

Because a target retry is signaled to the initiator, the initiator must relinquish the lock on the primary bus, and therefore the lock is not yet established.

The first locked transaction must be a read transaction. Subsequent locked transactions can be read or write transactions. Posted memory write transactions that are a part of the locked transaction sequence are still posted. Memory read transactions that are a part of the locked transaction sequence are not prefetched.

When the locked delayed read request is queued, Tsi350A does not queue any more transactions until the locked sequence is finished. Tsi350A signals a target retry to all transactions initiated subsequent to the locked read transaction that are intended for targets on the other side of Tsi350A. Tsi350A allows any transactions queued before the locked transaction to complete before initiating the locked transaction.

When the locked delayed read request transaction moves to the head of the delayed transaction queue, Tsi350A initiates the transaction as a locked read transaction by de-asserting S_LOCK_b on the secondary bus during the first address phase, and by asserting S_LOCK_b one cycle later. If S_LOCK_b is already asserted (used by another initiator), Tsi350A waits to request access to the secondary bus until S_LOCK_b is sampled de-asserted when the secondary bus is idle. Note that the existing lock on the secondary bus could not have crossed Tsi350A; otherwise, the pending queued locked transaction would not have been queued. When Tsi350A is able to complete a data transfer with the locked read transaction, the lock is established on the secondary bus.

When the initiator repeats the locked read transaction on the primary bus with the same address, transaction type, and byte enable bits, Tsi350A transfers the read data back to the initiator, and the lock is then also established on the primary bus.

For Tsi350A to recognize and respond to the initiator, the initiator's subsequent attempts of the read transaction must use the locked transaction sequence (de-assert P_LOCK_b during address phase, and assert P_LOCK_b one cycle later). If the LOCK_b sequence is not used in subsequent attempts, a master time-out condition may result. When a master time-out condition occurs, P_SERR_b is conditionally asserted (see [“Error Handling” on page 61](#)), the read data and queued read transaction are discarded, and the S_LOCK_b signal is de-asserted on the secondary bus.

Once the intended target has been locked, any subsequent locked transactions initiated on the primary bus that are forwarded by Tsi350A are driven as locked transactions on the secondary bus.

When Tsi350A receives a target abort or a master abort in response to the delayed locked read transaction, a target abort is returned to the initiator, and no locks are established on either the target or the initiator bus. Tsi350A resumes forwarding unlocked transactions in both directions.

When Tsi350A detects, on the secondary bus, a locked delayed transaction request intended for a target on the primary bus, Tsi350A queues and forwards the transaction as an unlocked transaction. Tsi350A ignores S_LOCK_b for upstream transactions and initiates all upstream transactions as unlocked transactions.

6.3 Ending Exclusive Access

After the lock has been acquired on both the primary and secondary buses, Tsi350A must maintain the lock on the secondary (target) bus for any subsequent locked transactions until the initiator relinquishes the lock.

The only time a target retry causes the lock to be relinquished is on the first transaction of a locked sequence. On subsequent transactions in the sequence, the target retry has no effect on the status of the lock signal.

An established target lock is maintained until the initiator relinquishes the lock. Tsi350A does not know whether the current transaction is the last one in a sequence of locked transactions until the initiator de-asserts the P_LOCK_b signal at the end of the transaction.

When the last locked transaction is a delayed transaction, Tsi350A has already completed the transaction on the secondary bus. In this case, as soon as Tsi350A detects that the initiator has relinquished the P_LOCK_b signal by sampling it in the de-asserted state while P_FRAME_b is de-asserted, Tsi350A de-asserts the S_LOCK_b signal on the secondary bus as soon as possible.

Because of this behavior, S_LOCK_b may not be de-asserted until several cycles after the last locked transaction has been completed on the secondary bus. As soon as Tsi350A has de-asserted S_LOCK_b to indicate the end of a sequence of locked transactions, it resumes forwarding unlocked transactions.

When the last locked transaction is a posted write transaction, Tsi350A de-asserts S_LOCK_b on the secondary bus at the end of the transaction because the lock was relinquished at the end of the write transaction on the primary bus.

When Tsi350A receives a target abort or a master abort in response to a locked delayed transaction, Tsi350A returns a target abort when the initiator repeats the locked transaction. The initiator must then de-assert P_LOCK_b at the end of the transaction. Tsi350A sets the appropriate status bits, flagging the abnormal target termination condition. Normal forwarding of unlocked posted and delayed transactions is resumed.

When Tsi350A receives a target abort or a master abort in response to a locked posted write transaction, Tsi350A cannot pass back that status to the initiator. Tsi350A asserts P_SERR_b when a target abort or a master abort is received during a locked posted write transaction, if the SERR_b enable bit is set in the command register. Signal P_SERR_b is asserted for the master abort condition if the master abort mode bit is set in the bridge control register.

7. PCI Bus Arbitration

This chapter discusses the following:

- “Overview” on page 73
- “Primary PCI Bus Arbitration” on page 73
- “Secondary PCI Bus Arbitration” on page 74
- “Bus Parking” on page 75

7.1 Overview

Tsi350A must arbitrate for use of the primary bus when forwarding upstream transactions, and for use of the secondary bus when forwarding downstream transactions. The arbiter for the primary bus resides external to Tsi350A, typically on the motherboard. For the secondary PCI bus, Tsi350A implements an internal arbiter. This arbiter can be disabled, and an external arbiter can be used instead.

This chapter describes primary and secondary bus arbitration.

7.2 Primary PCI Bus Arbitration

Tsi350A implements a request output pin, P_REQ_b, and a grant input pin, P_GNT_b, for primary PCI bus arbitration. Tsi350A asserts P_REQ_b when forwarding transactions upstream; that is, it acts as initiator on the primary PCI bus. As long as at least one pending transaction resides in the queues in the upstream direction, either posted write data or delayed transaction requests, Tsi350A keeps P_REQ_b asserted. However, if a target retry, target disconnect, or a target abort is received in response to a transaction initiated by Tsi350A on the primary PCI bus, Tsi350A de-asserts P_REQ_b for two PCI clock cycles.

For posted write transactions (“Posted Write Transactions” on page 28), P_REQ_b is asserted a few cycles after S_DEVSEL_b is asserted. For delayed read and write requests, P_REQ_b is not asserted until the transaction request has been completely queued in the delayed transaction queue (target retry has been returned to the initiator) and is at the head of the delayed transaction queue.

When P_GNT_b is asserted low by the primary bus arbiter after Tsi350A has asserted P_REQ_b, Tsi350A initiates a transaction on the primary bus during the next PCI clock cycle. If P_GNT_b is asserted to the Tsi350A and the Tsi350A's P_REQ_b is not asserted, the Tsi350A parks P_AD, P_CBE_b, and P_PAR by driving them to valid logic levels. When the primary bus is parked at Tsi350A and the Tsi350A has a transaction to initiate on the primary bus, Tsi350A starts the transaction (asserts FRAME_b) if P_GNT_b was asserted during the previous cycle.

7.3 Secondary PCI Bus Arbitration

Tsi350A implements an internal secondary PCI bus arbiter. This arbiter supports nine external masters in addition to Tsi350A. The internal arbiter can be disabled, and an external arbiter can be used instead for secondary bus arbitration.

7.3.1 Secondary Bus Arbitration Using the Internal Arbiter

To use the internal arbiter, the secondary bus arbiter enable pin, S_CFN_b, must be tied low. Tsi350A has nine secondary bus request input pins, S_REQ_b[8:0], and nine secondary bus output grant pins, S_GNT_b[8:0], to support external secondary bus masters. The Tsi350A specific secondary bus request and grant signals are connected internally to the arbiter and are not brought out to external pins when S_CFN_b is low.

The secondary arbiter supports a programmable 2-level rotating algorithm. Two groups of masters are assigned, a high priority group and a low priority group. The low priority group as a whole represents one entry in the high priority group; that is, if the high priority group consists of n masters, then in at least every $n+1$ transactions the highest priority is assigned to the low priority group. Priority rotates evenly among the low priority group. Therefore, members of the high priority group can be serviced n transactions out of $n+1$, while one member of the low priority group is serviced once every $n+1$ transactions.

Each bus master, including Tsi350A, can be configured to be in either the low priority group or the high priority group by setting the corresponding priority bit in the arbiter control register in device-specific configuration space. Each master has a corresponding bit. If the bit is set to 1, the master is assigned to the high priority group. If the bit is set to 0, the master is assigned to the low priority group. If all the masters are assigned to one group, the algorithm defaults to a straight rotating priority among all the masters. After reset, all external masters are assigned to the low priority group, and Tsi350A is assigned to the high priority group. Tsi350A receives highest priority on the target bus every other transaction, and priority rotates evenly among the other masters.

Priorities are reevaluated every time S_FRAME_b is asserted, that is, at the start of each new transaction on the secondary PCI bus. From this point until the time that the next transaction starts, the arbiter asserts the grant signal corresponding to the highest priority request that is asserted. When priorities are reevaluated, the highest priority is assigned to the next highest priority master relative to the master that initiated the previous transaction. The master that initiated the last transaction now has the lowest priority in its group.

If Tsi350A detects that an initiator has failed to assert S_FRAME_b after 16 cycles of both grant assertion and a secondary idle bus condition, the arbiter de-asserts the grant.

To prevent bus contention, if the secondary PCI bus is idle, the arbiter never asserts one grant signal in the same PCI cycle in which it de-asserts another. It de-asserts one grant, and then asserts the next grant, no earlier than one PCI clock cycle later. If the secondary PCI bus is busy, that is, either S_FRAME_b or S_IRDY_b is asserted, the arbiter can de-assert one grant and assert another grant during the same PCI clock cycle.

7.3.2 Secondary Bus Arbitration Using an External Arbiter

The internal arbiter is disabled when the secondary bus central function control pin, S_CFN_b, is pulled high. An external arbiter must then be used.

When S_CFN_b is tied high, Tsi350A reconfigures two pins to be external request and grant pins. The S_GNT_b[0] pin is reconfigured to be Tsi350A's external request pin because it is an output. The S_REQ_b[0] pin is reconfigured to be the external grant pin because it is an input. When an external arbiter is used, Tsi350A uses the S_GNT_b[0] pin to request the secondary bus. When the reconfigured S_REQ_b[0] pin is asserted low after Tsi350A has asserted S_GNT_b[0], Tsi350A initiates a transaction on the secondary bus one cycle later. If S_REQ_b[0] is asserted and Tsi350A has not asserted S_GNT_b[0], Tsi350A parks the S_AD, S_CBE_b, and S_PAR pins by driving them to valid logic levels.

The unused secondary bus grant outputs, S_GNT_b[8:1], are driven high. Unused secondary bus request inputs, S_REQ_b[8:1], should be pulled high.

7.4 Bus Parking

Bus parking refers to driving the AD, C/BE_b, and PAR lines to a known value while the bus is idle. In general, the device implementing the bus arbiter is responsible for parking the bus or assigning another device to park the bus. A device parks the bus when the bus is idle, its bus grant is asserted, and the device's request is not asserted. The AD and C/BE_b signals should be driven first, with the PAR signal driven one cycle later.

Tsi350A parks the primary bus only when P_GNT_b is asserted, P_REQ_b is de-asserted, and the primary PCI bus is idle. When P_GNT_b is de-asserted, Tsi350A tristates the P_AD, P_CBE_b, and P_PAR signals on the next PCI clock cycle. If Tsi350A is parking the primary PCI bus and wants to initiate a transaction on that bus, then Tsi350A can start the transaction on the next PCI clock cycle by asserting P_FRAME_b if P_GNT_b is still asserted.

If the internal secondary bus arbiter is enabled, the secondary bus is always parked at the last master that used the PCI bus. That is, Tsi350A keeps the secondary bus grant asserted to a particular master until a new secondary bus request comes along. After reset, Tsi350A parks the secondary bus at itself until transactions start occurring on the secondary bus. If the internal arbiter is disabled, Tsi350A parks the secondary bus only when the reconfigured grant signal, S_REQ_b[0], is asserted and the secondary bus is idle.

8. General Purpose I/O

This chapter discusses the following:

- “Overview” on page 77
- “GPIO Control Registers” on page 77
- “Secondary Clock Control” on page 78
- “Live Insertion” on page 80
- “CompactPCI Hot-swap Support” on page 80

8.1 Overview

Tsi350A implements a 4-pin general-purpose I/O GPIO interface. During normal operation, the GPIO interface is controlled by device-specific configuration registers. In addition, the GPIO interface can be used for the following functions:

- During secondary interface reset, the GPIO interface can be used to shift in a 16-bit serial stream that serves as a secondary bus clock disable mask.
- A live insertion bit can be used, along with the GPIO[3] pin, to bring Tsi350A gracefully to a halt through hardware, permitting live insertion of option cards behind Tsi350A.

8.2 GPIO Control Registers

During normal operation, the GPIO interface is controlled by the following device-specific configuration registers:

- GPIO output data register
- GPIO output enable control register
- GPIO input data register

These registers consist of five 8-bit fields:

- Write-1-to-set output data field
- Write-1-to-clear output data field
- Write-1-to-set signal output enable control field
- Write-1-to-clear signal output enable control field
- Input data field

The bottom 4 bits of the output enable fields control whether each GPIO signal is input only or bi-directional. Each signal is controlled independently by a bit in each output enable control field. If a one is written to the write-1-to-set field, the corresponding pin is activated as an output. If a one is written to the write-1-to-clear field, the output driver is tristated, and the pin is then input only. Writing zeros to these registers has no effect. The reset state for these signals is input only.

The input data field is read only and reflects the current value of the GPIO pins. A Type 0 configuration read operation to this address is used to obtain the values of these pins. All pins can be read at any time, whether configured as input only or as bi-directional.

The output data fields also use the write-1-to-set and write-1-to-clear method. If a 1 is written to the write-1-to-set field and the pin is enabled as an output, the corresponding GPIO output is driven high. If a 1 is written to the write-1-to-clear field and the pin is enabled as an output, the corresponding GPIO output is driven low. Writing zeros to these registers has no effect. The value written to the output register will be driven only when the GPIO signal is configured as bi-directional. A Type 0 configuration write operation is used to program these fields. The reset value for the output is zero.

8.3 Secondary Clock Control

Tsi350A uses the GPIO pins and the MSK_IN signal to input a 16-bit serial data stream. This data stream is shifted into the secondary clock control register and is used for selectively disabling secondary clock outputs.

The serial data stream is shifted in as soon as P_RST_b is detected de-asserted and the secondary reset signal, S_RST_b is detected asserted. The de-assertion of S_RST_b is delayed until Tsi350A completes shifting in the clock mask data. After shifting the clock mask data, Tsi350A keeps the S_RST_b asserted for 100 μ s to satisfy the trst-clk timing. After that, the GPIO pins can be used as general-purpose IO pins.

An external shift register should be used to load and shift the data. The GPIO[0] and GPIO[2] pins are used for shift register control and serial data input.

The data is input through the dedicated input signal, MSK_IN.

The shift register circuitry is not necessary for correct operation of Tsi350A. The shift registers can be eliminated, and MSK_IN can be tied low to enable all secondary clock outputs or tied high to force all secondary clock outputs high.

Table 10 shows the format for the clock mask data.

Table 10: Clock Mask Data Format

Bit	Clock
[0:1]	S_CLKOUT[0]
[2:3]	S_CLKOUT[1]
[4:5]	S_CLKOUT[2]
[6:7]	S_CLKOUT[3]
8	S_CLKOUT[4]
9	S_CLKOUT[5]
10	S_CLKOUT[6]
11	S_CLKOUT[7]
12	S_CLKOUT[8]
13	S_CLKOUT[9]
[14:15]	Reserved

Figure 10-1 below shows a timing diagram for the load and for the beginning of the shift operation.

Figure 6: Clock Mask Load and Shift Timing

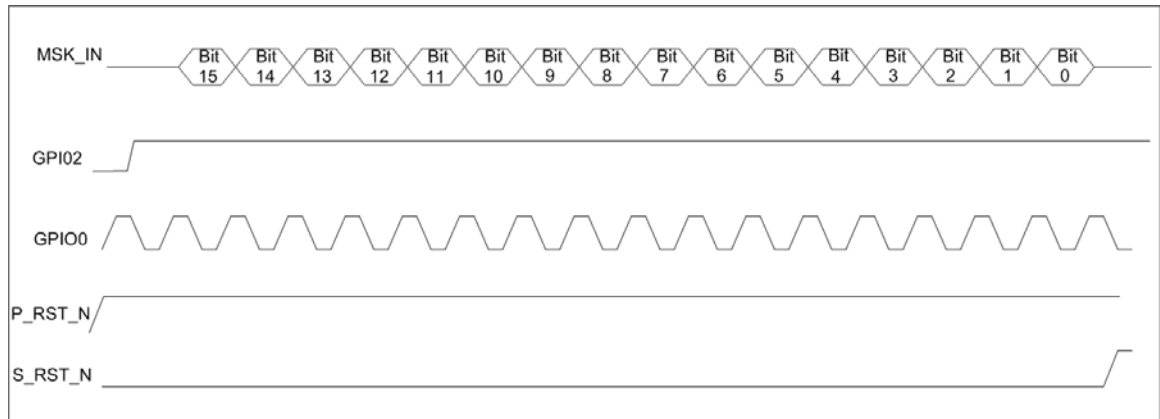

After the shift operation is complete, Tsi350A tristates the GPIO signals and can de-assert S_RST_b if the secondary reset bit is clear. Tsi350A then ignores MSK_IN. Control of the GPIO signal now reverts to Tsi350A GPIO control registers. The clock disable mask can be modified subsequently through a configuration write command to the secondary clock control register in device-specific configuration space.

8.4 Live Insertion

The GPIO[3] pin can be used, along with a live insertion mode bit, to disable transaction forwarding.



This feature is not available when Tsi350A is in CompactPCI hot-swap mode because GPIO[3] is used as the HS_SWITCH_b input in this mode.

To enable live insertion mode, the live insertion mode bit in the chip control register must be set to 1, and the output enable control for GPIO[3] must be set to input only in the GPIO output enable control register. When live insertion mode is enabled, whenever GPIO[3] is driven to a value of 1, the I/O enable, the memory enable, and the master enable bits are internally masked to 0. This means that, as a target, Tsi350A no longer accepts any I/O or memory transactions, on either interface. When read, the register bits still reflect the value originally written by a configuration write command; when GPIO[3] is de-asserted, the internal enable bits return to their original value (as they appear when read from the command register). When this mode is enabled, as a master, Tsi350A completes any posted write or delayed request transactions that have already been queued.

Delayed completion transactions are not returned to the master in this mode because Tsi350A is not responding to any I/O or memory transactions during this time.



The Tsi350A continues to accept configuration transactions in live insertion mode.

Once live insertion mode brings Tsi350A to a halt and queued transactions are completed, the secondary reset bit in the bridge control register can be used to assert S_RST_b, if desired, to reset and tristate secondary bus devices, and to enable any live insertion hardware.

8.5 CompactPCI Hot-swap Support

The Tsi350A is hot-swap friendly silicon that supports all of the hot-swap capable features, contains support for software control, and integrates circuitry required by the *PICMG CompactPCI Hot-Swap Specification*.



Hot-swap support is only available in the 208 Pin PQFP package. The 256-pin PBGA package does not support Hot-swap functionality.

- To be hot-swap capable, the Tsi350A supports the following:
- Compliance with *PCI Local Bus Specification*.
- Tolerance of V_{DD} from early power.
- Asynchronous reset.
- Tolerance of precharge voltage.
- I/O buffers that meet modified V/I requirements.
- Limited I/O terminal voltage at pre-charge voltage.
- Hot-swap control and status programming via extended PCI capabilities linked list.

- Hot-swap terminals: HS_ENUM_b, HS_SWITCH_b, and HS_LED, cPCI hot-swap defines a process for installing and removing PCI boards without adversely affecting a running system. The Tsi350A provides this functionality such that it can be implemented on a board that can be removed and inserted in a hot-swap system.

Table 11: Tsi350A Hot-Swap Mode Selection

MS0	MS1	Mode
0	0	Compact PCI hot-swap friendly PCI Bus Power Management Interface Specification (Revision 1.1) GPIO[3] functions as HS_SWITCH_b
1	X	Compact PCI hot-swap disabled PCI Bus Power Management Interface Specification (Revision 1.1) GPIO[3] functions as GPIO[3]
0	1	Compact PCI hot-swap disabled PCI Bus Power Management Interface Specification (Revision 1.1) GPIO[3] functions as GPIO[3]

Tsi350A provides three terminals to support hot-swap when configured to be in hot-swap mode:

- HS_ENUM_b** (output) - Indicates to the system that an insertion event occurred or that a removal event is about to occur.
- HS_SWITCH_b** (input) - Indicates the state of a board ejector handle.
- HS_LED** (output) - Drives a blue LED to signal insertion- and removal-ready status.

9. Clocks

This chapter discusses the following:

- “Overview” on page 83
 - “Primary and Secondary Clock Inputs” on page 83
 - “Secondary Clock Outputs” on page 84
-

9.1 Overview

Tsi350A implements a separate clock input for each PCI interface. The primary interface is synchronized to the primary clock input, P_CLK, and the secondary interface is synchronized to the secondary clock input, S_CLK.

9.2 Primary and Secondary Clock Inputs

Tsi350A operates between 0 MHz to 66 MHz on both interfaces. P_CLK and S_CLK can be synchronous or asynchronous in phase and frequency.

9.2.1 Synchronous Secondary Clock Input

In synchronous clocking mode, the secondary clock input S_CLK is connected to one of the secondary clock outputs (S_CLK_O). The S_CLK_O outputs are derived from P_CLK.

9.2.2 Asynchronous Secondary Clock Input

In asynchronous clocking mode, the secondary clock input S_CLK is driven by an external clock source.

9.3 Secondary Clock Outputs

Tsi350A has 10 secondary clock outputs, S_CLK_O[9:0], that can be used as clock inputs for up to nine external secondary bus devices and for Tsi350A secondary clock input.

The S_CLK_O outputs are derived from P_CLK (that is they are synchronous to the primary clock). When both Tsi350A PCI interfaces operate at 66MHz, the Tsi350A secondary clock outputs are identical in phase to the primary clock input (P_CLK). Tsi350A divides the primary bus clock P_CLK by two to generate the secondary bus clock outputs whenever the primary bus is operating at 66 MHz and the secondary bus is operating at 33 MHz. The bridge detects this condition when P_M66EN is high and S_M66EN is low for the above operation. The output clocks on secondary will be generated only after the de-assertion of P_RST_b. Hence to satisfy Trst-clk timing parameter the secondary reset is delayed for 100 μs after reading the mask inputs.

The following rules should be followed regarding the secondary output clocks:

- Each secondary clock output is limited to one load.
- Unused secondary clocks should be disabled through mask input or through configuration register.

Table 12 shows the options for generating the Tsi350A S_CLK_O outputs:

Table 12: Tsi350A S_CLK_O clock outputs

P_M66EN	S_M66EN	S_CLK_O
1	0	P_CLK/2
1	1	P_CLK
0	X	P_CLK

9.3.1 Running the Secondary Clock Faster than the Primary Clock

The Tsi350A supports running the Secondary PCI port faster than the Primary PCI port. The Tsi350A asynchronous design supports standard 66MHz to 33MHz operation as well as 33MHz to 66MHz operation. System designers must provide the faster clock source either through an oscillator or a clock generator.

10. PCI Power Management

This chapter discusses the following:

- “Overview of PCI Power Management” on page 85

10.1 Overview of PCI Power Management

Tsi350A incorporates functionality that meets the requirements of the PCI Power Management Specification, Revision 1.0. These features include:

- PCI Power Management registers using the Enhanced Capabilities Port (ECP) address mechanism
- Support for D0, D3hot and D3cold power management states
- Support for D0, D1, D2, D3hot, and D3cold power management states for devices behind the bridge
- Support of the B2 secondary bus power state when in the D3hot power management state. [Table 13](#) shows the states and related actions that Tsi350A performs during power management transitions. (No other transactions are permitted.)

Table 13: Power Management Transitions

Current State	Next State	Action
D0	D3cold	Power has been removed from Tsi350A. A power-up reset must be performed to bring Tsi350A to D0.
D0	D3hot	If enabled to do so by the BPCCE pin, Tsi350A will disable the secondary clocks and drive them low.
D0	D2	Un-implemented power state. Tsi350A will ignore the write to the power state bits (power state remains at D0).
D0	D1	Un-implemented power state. Tsi350A will ignore the write to the power state bits (power state remains at D0).
D3hot	D0	Tsi350A enables secondary clock outputs and performs an internal chip reset. Signal S_RST_b will not be asserted. All registers will be returned to the reset values and buffers will be cleared.
D3hot	D3cold	Power has been removed from Tsi350A. A power-up reset must be performed to bring Tsi350A to D0.
D3cold	D0	Power-up reset. Tsi350A performs the standard power-up reset functions as described in Chapter 13.

PME_b signals are routed from downstream devices *around* PCI-to-PCI bridges. PME_b signals do not pass through PCI-to-PCI bridges.

11. Reset

This chapter discusses the following:

- “Primary Interface Reset” on page 87
- “Secondary Interface Reset” on page 87
- “Chip Reset” on page 88

11.1 Primary Interface Reset

Tsi350A has one reset input, P_RST_b. When P_RST_b is asserted, the following events occur:

- Tsi350A immediately tristates all primary and secondary PCI interface signals.
- Tsi350A performs a chip reset.
- Registers that have default values are reset.

The P_RST_b asserting and de-asserting edges can be asynchronous to P_CLK and S_CLK.

11.2 Secondary Interface Reset

Tsi350A is responsible for driving the secondary bus reset signal, S_RST_b. Tsi350A asserts S_RST_b when any of the following conditions is met:

- P_RST_b assertion - S_RST_b is asserted when P_RST_b is asserted on the primary interface of Tsi350A. The P_RST_b de-assertion triggers the serial mask shift operation for the secondary output clocks. Following the completion of mask shift operation, Tsi350A de-asserts S_RST_b after a 100 us period.
- Programming bit 6, Secondary Bus Reset, in the Bridge Control register (3Eh) - Software can force S_RST_b by programming this bit to '1'. The software should clear this bit to '0' to de-assert S_RST_b. Following the clear operation, the Tsi350A de-asserts S_RST_b after a 100 us period.
- Programming bit 0, Chip Reset, in the Diagnostic Control register (41h) - Software can program this bit to '1' to assert S_RST_b on the secondary interface. The Tsi350A de-asserts S_RST_b automatically after 100 us and clears the bit to '0', provided the secondary reset bit is cleared in the “[Bridge Control Register—Offset 0x3C](#)” on page 147. Writing a 1 to the Chip Reset will set the Secondary Bus Reset bit in the Bridge Control Register. Signal S_RST_b remains asserted until a configuration write operation clears the secondary reset bit and the secondary clock serial mask has been shifted in.

When S_RST_b is asserted, all secondary PCI interface control signals, including the secondary grant outputs, are immediately tristated. Signals S_AD, S_CBE_b, and S_PAR are driven low for the duration of S_RST_b assertion. All posted write and delayed transaction data buffers are reset; therefore, any transactions residing in Tsi350A buffers at the time of secondary reset are discarded.

When S_RST_b is asserted by means of the secondary reset bit, Tsi350A remains accessible during secondary interface reset and continues to respond to accesses to its configuration space from the primary interface.

11.3 Chip Reset

The chip reset bit in the diagnostic control register can be used to reset Tsi350A and the secondary bus.

When the chip reset bit is set, all registers and chip state are reset and all signals are tristated. In addition, S_RST_b is asserted, and the secondary reset bit is automatically set. Signal S_RST_b remains asserted until a configuration write operation clears the secondary reset bit and the serial clock mask has been shifted in.

As soon as chip reset completes, within 20 PCI clock cycles after completion of the configuration write operation that sets the chip reset bit, the chip reset bit automatically clears and the chip is ready for configuration.

During chip reset, Tsi350A is inaccessible.

12. JTAG Module

This chapter discusses the following:

- “Overview of the JTAG Module” on page 89
- “JTAG Signal Pins” on page 89
- “Test Access Port (TAP) Controller” on page 90
- “Initialization” on page 91

12.1 Overview of the JTAG Module

This chapter describes Tsi350A’s implementation of a joint test action group (JTAG) test port according to IEEE Standard 1149.1, IEEE Standard Test Access Port and Boundary-Scan Architecture.

Tsi350A contains a serial-scan test port that conforms to IEEE standard 1149.1. The JTAG test port consists of the following:

- 5-wire test access port
- Test Access Port (TAP) controller
- Instruction register
- Bypass register
- Boundary-scan register
- ID Code Register

12.2 JTAG Signal Pins

The instruction register is loaded through the TDI pin. The instruction register has a shift-in stage from which the instruction is then updated in parallel.

Table 14: JTAG Signal Pins

Signal Name	Type	Description
TDI	I	JTAG Serial Data In - TDI is the serial input through which JTAG instructions and test data enter the JTAG interface. The new data on TDI is sampled on the rising edge of TCK. An un-terminated TDI produces the same result as if TDI were driven high.
TDO	O	JTAG Serial Data Out - TDO is the serial output through which test instructions and data from the test logic leave the Tsi350A. This is tri-state signal, enabled from the Test Access Port (TAP) Controller.
TMS	I	JTAG Test Mode Select - TMS causes state transitions in the TAP controller. An un-driven TMS has the same result as if it were driven high.

Table 14: JTAG Signal Pins

Signal Name	Type	Description
TCK	I	JTAG Boundary-Scan Clock - TCK is the clock controlling the JTAG logic.
TRST_b	I	JTAG TAP Reset - When asserted low, the TAP controller is asynchronously forced to enter a reset state, which in turn asynchronously initializes other test logic. An un-terminated TRST_b produces the same result as if it were driven high. TRST_b must be pulled to GND through a 100Ω resistor if the JTAG interface is unused.

12.3 Test Access Port (TAP) Controller

The Test Access Port (TAP) controller is a finite state machine that interprets IEEE 1149.1 protocols received through the TMS line.

The state transitions in the controller are caused by the TMS signal on the rising edge of TCK. In each state, the controller generates appropriate clock and control signals that control the operation of the test features. After entry into a state, test feature operations are initiated on the rising edge of TCK.

12.3.1 Instruction Register

The 4-bit instruction register selects the test modes and features. The instruction register bits are interpreted as instructions, as shown in [Table 15](#).

Table 15: JTAG Instructions

Number	Instruction	Opcode
1	BYPASS	1111
2	EXTEST	0000
3	SAMPLE/PRELOAD	0100
4	IDCODE	1101
5	SCAN MODE	0111
6	HIGHZ	0101

12.3.2 Bypass Register

The bypass register is a 1-bit shift register that provides a means for effectively bypassing the JTAG test logic through a single-bit serial connection through the chip from TDI to TDO. At board level testing, this helps reduce overall length of the scan ring.

12.3.3 Boundary-Scan Register

The boundary-scan register is a single-shift register-based path formed by boundary-scan cells placed at the chip's signal pins. The register is accessed through the JTAG port's TDI and TDO pins.

12.3.3.1 Boundary-Scan Register Cells

Each boundary-scan cell operates in conjunction with the current instruction and the current state in the TAP controller state machine. The function of the BSR cells is determined by the associated pins, as follows:

- **Input-only pins**—The boundary-scan cell is basically a 1-bit shift register. The cell supports sample and shift functions.
- **Output-only pins**—The boundary-scan cell comprises a 2-bit shift register and an output multiplexer. The cell supports the sample, shift, and drive output functions.
- **Bi-directional pins**—The boundary-scan cell is identical to the output-only pin cell, but it captures test data from the incoming data line. The cell supports sample, shift, drive output, and hold output functions. It is used at all I/O pins.

12.4 Initialization

The Test Access Port (TAP) controller and the instruction register output latches are initialized when the TRST_b input is asserted. The TAP controller enters the test-logic reset state. The instruction register is reset to hold the ID Code register instruction. During test-logic reset state, all JTAG test logic is disabled, and the chip performs normal functions. The TAP controller leaves this state only when an appropriate JTAG test operation sequence is sent on the TMS and TCK pins.

For Tsi350A to operate properly, the JTAG logic must be reset. JTAG can be reset in the following ways:

1. If the JTAG logic is not being used, TRST_b must be tied to GND with a 100ohm resistor.
2. If the JTAG logic is to be used, the part goes into normal mode if TMS is asserted high for at least 10 cycles of TCK, thus clearing JTAG logic.

13. Signals and Pinout

This chapter discusses the following:

- “Overview of Signals and Pinout” on page 93
- “Signals” on page 95
- “Pinout” on page 104

13.1 Overview of Signals and Pinout

This chapter provides detailed descriptions of Tsi350A signal pins, grouped by function. **Table 16** describes the signal pin functional groups, and the following sections describe the signals in each group.

Table 16: Tsi350A Signal Pins

Function	Description
Primary PCI Interface	All PCI pins required by the <i>PCI-to-PCI Bridge Architecture Specification, Revision 1.2</i> .
Secondary PCI Interface	All PCI pins required by the <i>PCI-to-PCI Bridge Architecture Specification, Revision 1.2</i> .
Secondary PCI Bus Arbiter	Nine request/grant pairs of pins for the secondary PCI bus, plus an arbiter enable pin.
General-Purpose I/O	Four general-purpose pins.
Clock Signal Pins	Two clock inputs - one for each PCI interface. Ten clock outputs – nine for external secondary PCI bus devices plus one for Tsi350A.
Reset Signal Pins	Primary interface reset input. Secondary interface reset output.
Miscellaneous	Secondary clock output disable. Two input voltage signaling level pins. Three pins controlling 66 MHz operation.
JTAG Signal Pins	All JTAG pins required by IEEE standard 1149.1.

Table 17 defines the signal type abbreviations used in the signal tables.

Table 17: Tsi350A Signal Types

Signal Type	Description
I	Standard input only.
O	Standard output only.
TS	Tristate bi-directional.
STS	Sustained tristate. Active low signal must be pulled high for one cycle when de-asserting.
OD	Standard open drain.



The *_b* signal name suffix indicates that the signal is asserted when it is at a low voltage level and corresponds to the *#* suffix in the *PCI Local Bus Specification*. If this suffix is not present, the signal is asserted when it is at a high voltage level.

13.2 Signals

13.2.1 Primary PCI Bus Interface Signals

Table 18: Primary PCI Bus Interface Signals

Signal Name	Type	Description
P_AD[31:0]	TS	Primary Bus: Address Data Bus This is a bi-directional multiplexed address and data bus. During address phase, this bus carries the address of the target device. In data phase, it carries the data to or from the target of the transaction.
P_CBE[3:0]_b	TS	Primary Bus: Command / Byte Enable These signals carry the command during the address phase and byte-enables during the data phase.
P_PAR	TS	Primary Bus: Parity This bi-directional signal indicates the even parity of address P_AD[31:0] and command bits P_CBE[3:0]_b for an address phase or even parity of data and byte enables for a data phase of a PCI cycle. The PAR signal will be driven by Tsi350A, when it drives address or data on the AD bus.
P_FRAME_b	STS	Primary Bus: FRAME This bi-directional active low signal indicates the start of a PCI transaction. Frame continues to be asserted during the transaction. When de-asserted, the transaction is in the final data phase.
P_IRDY_b	STS	Primary Bus: Initiator Ready This bi-directional active low signal indicates the initiating device's ability to complete the current data phase of the transaction. A data phase is completed when both P_IRDY_b and P_TRDY_b are sampled asserted.
P_TRDY_b	STS	Primary Bus: Target Ready This bi-directional active low signal indicates the target device's ability to complete the current data phase of the transaction. A data phase is completed when both P_IRDY_b and P_TRDY_b are sampled asserted.
P_DEVSEL_b	STS	Primary Bus: Device Select This bi-directional active low signal is asserted when the target device has decoded the current address on the bus and has found a match for that address. Tsi350A drives this signal on the primary when it is the target of a transaction.

Table 18: Primary PCI Bus Interface Signals

Signal Name	Type	Description
P_STOP_b	STS	<p>Primary Bus: Stop</p> <p>This bi-directional active low signal indicates to the requesting master to terminate the current transaction.</p> <p>When P_STOP_b is asserted in conjunction with P_TRDY_b and P_DEVSEL_b assertion, a disconnect with data transfer is being signaled.</p> <p>When P_STOP_b and P_DEVSEL_b are asserted, but P_TRDY_b is de-asserted, a target disconnect without data transfer is being signaled. When this occurs on the first data phase, that is, no data is transferred during the transaction, this is referred to as a target retry.</p> <p>When P_STOP_b is asserted and P_DEVSEL_b is de-asserted, the target is signaling a target abort.</p> <p>When the primary bus is idle, P_STOP_b is driven to a de-asserted state for one cycle and then is sustained by an external pull-up resistor.</p>
P_LOCK_b	I	<p>Primary Bus: Lock</p> <p>This input signal when high indicates that the current transaction is a locked transaction.</p>
P_IDSEL	I	<p>Primary Bus: IDSEL_b.</p> <p>Signal P_IDSEL is used as the chip select line for Type 0 configuration accesses to Tsi350A configuration space.</p> <p>When P_IDSEL is asserted during the address phase of a Type 0 configuration transaction, the Tsi350A responds to the transaction by asserting P_DEVSEL_b.</p>
P_PERR_b	STS	<p>Primary Bus: PERR_b.</p> <p>This bi-directional signal is for reporting data parity errors during the transaction. Signal P_PERR_b is asserted by the target during write transactions, and by the initiator during read transactions.</p> <p>When the primary bus is idle, P_PERR_b is driven to a de-asserted state for one cycle and then is sustained by an external pull-up resistor.</p>
P_SERR_b	OD	<p>Primary Bus: System Error</p> <p>This is an active low output signal used for reporting address parity error and other system errors. Tsi350A can assert P_SERR_b for the following reasons:</p> <ul style="list-style-type: none"> • Address parity error • Posted write data parity error on target bus • Secondary bus S_SERR_b assertion • Master abort during posted write transaction • Target abort during posted write transaction • Posted write transaction discarded • Delayed write request discarded • Delayed read request discarded • Delayed transaction master time-out <p>Signal P_SERR_b is pulled up through an external resistor.</p>

Table 18: Primary PCI Bus Interface Signals

Signal Name	Type	Description
P_REQ_b	TS	Primary Bus: Request This is an active low output signal asserted by Tsi350A requesting for the ownership of the bus.
P_GNT_b	I	Primary Bus: Grant This active low input signal indicates that Tsi350A can take the ownership of the bus after the completion of current transaction on the bus.

13.2.2 Secondary PCI Bus Interface Signals

Table 19: Secondary PCI Bus Interface Signals

Signal Name	Type	Description
S_AD[31:0]	TS	Secondary Bus: Address Data Bus This is a bi-directional multiplexed address and data bus. During address phase, this bus carries the address of the target device. In data phase, it carries the data to or from the target of the transaction.
S_CBE[3:0]_b	TS	Secondary Bus: Command/Byte-Enable These signals carry the command during the address phase and byte-enables during the data phase.
S_PAR	TS	Secondary Bus: Parity This bi-directional signal indicates the even parity of address S_AD[31:0] and command bits S_CBE[3:0]_b for an address phase or even parity of data and byte enables for a data phase of a PCI cycle. Parity is always valid for the transfer that occurred the previous clock cycle. The PAR signal will be driven by Tsi350A, when it drives address or data on the AD bus.
S_FRAME_b	STS	Secondary Bus: FRAME This bi-directional active low signal indicates the start of a PCI transaction. Frame continues to be asserted during the transaction. When de-asserted, the transaction is in the final data phase.
S_IRDY_b	STS	Secondary Bus: Initiator Ready This bi-directional active low signal indicates the initiating device's ability to complete the current data phase of the transaction. A data phase is completed when both S_IRDY_b and S_TRDY_b are sampled asserted.
S_TRDY_b	STS	Secondary Bus: Target Ready This bi-directional active low signal indicates the target device's ability to complete the current data phase of the transaction. A data phase is completed when both S_IRDY_b and S_TRDY_b are sampled asserted.
S_DEVSEL_b	STS	Secondary Bus: Device Select This bi-directional active low signal is asserted when the target has decoded the current address on the bus and has found a match for that address. Tsi350A drives this signal on the Secondary Bus when it is the target of a transaction.

Table 19: Secondary PCI Bus Interface Signals

Signal Name	Type	Description
S_STOP_b	STS	<p>Secondary Bus: Stop</p> <p>This bi-directional active low signal indicates to the requesting master to terminate the current transaction.</p> <p>When S_STOP_b is asserted in conjunction with S_TRDY_b and S_DEVSEL_b assertion, a disconnect with data transfer is being signaled.</p> <p>When S_STOP_b and S_DEVSEL_b are asserted, but S_TRDY_b is de-asserted, a target disconnect without data transfer is being signaled. When this occurs on the first data phase, that is, no data is transferred during the transaction, this is referred to as a target retry.</p> <p>When S_STOP_b is asserted and S_DEVSEL_b is de-asserted, the target is signaling a target abort. When the secondary bus is idle, S_STOP_b is driven to a de-asserted state for one cycle and then is sustained by an external pull-up resistor.</p>
S_LOCK_b	STS	<p>Secondary Bus: Lock</p> <p>This bi-directional signal when high indicates that the current transaction on the Secondary Bus is a locked transaction. S_LOCK_b is de-asserted during the first address phase of a transaction and is asserted one clock cycle later by Tsi350A when it is propagating a locked transaction downstream.</p> <p>Tsi350A does not propagate locked transactions upstream.</p> <p>Tsi350A continues to assert S_LOCK_b until the address phase of the next locked transaction, or until the lock is released. When the lock is released, S_LOCK_b is driven to a de-asserted state for one cycle and then is sustained by an external pull-up resistor.</p>
S_PERR_b	STS	<p>Secondary Bus: PERR_b</p> <p>Signal S_PERR_b is asserted when a data parity error is detected for data received on the secondary interface. The timing of S_PERR_b corresponds to S_PAR driven one cycle earlier and S_AD driven two cycles earlier. Signal S_PERR_b is asserted by the target during write transactions, and by the initiator during read transactions. When the secondary bus is idle, S_PERR_b is driven to a de-asserted state for one cycle and then is sustained by an external pull-up resistor.</p>
S_SERR_b	I	<p>Secondary Bus: System Error</p> <p>This is an active low input signal used by secondary devices for reporting address parity error and other system errors. This signal can be driven low by any device except Tsi350A on the secondary bus to indicate a system error condition. Tsi350A samples S_SERR_b as an input and conditionally forwards it to the primary bus on P_SERR_b. Tsi350A does not drive S_SERR_b. Signal S_SERR_b is pulled up through an external resistor.</p>

13.2.3 Secondary Bus Arbitration Signals

Table 20: Secondary PCI Bus Arbitration Signals

Signal Name	Type	Description
S_REQ_b[8:0]	I	<p>Secondary Bus: Request</p> <p>These are active low request inputs from the devices on the Secondary Bus. Each request line is connected to a device on the Secondary Bus. The devices request for the ownership of the bus by asserting the request lines. The bridge supports nine request inputs. Based on the priority level the request will be processed by the bridge. If the internal arbiter is disabled (S_CFN_b tied high), S_REQ_b[0] is reconfigured to be an external secondary grant input for Tsi350A. In this case, an asserted level on S_REQ_b[0] indicates that Tsi350A can start a transaction on the secondary PCI bus if the bus is idle.</p>
S_GNT_b[8:0]	TS	<p>Secondary Bus: Grant</p> <p>These are active low grant outputs from the Tsi350A to the devices on the Secondary Bus. Each grant line is connected to a device on the Secondary Bus. The S_GNT lines are asserted by the internal arbiter based on the priority. The grant line when active signals the device to take the ownership of the bus after the completion of current transaction on the bus. To support nine request lines the bridge drive nine independent grant lines on the secondary.</p>
S_CFN_b	I	<p>Secondary Bus: Central Function Enable</p> <p>When connected low, S_CFN_b enables the Tsi350A secondary bus internal arbiter. When tied high, S_CFN_b disables the internal arbiter. Signal S_REQ_b[0] is reconfigured to be Tsi350A secondary bus grant input, and S_GNT_b[0] is reconfigured to be Tsi350A secondary bus request output, when an external arbiter is used. If the entries in the bridge are empty, the bridge parks the secondary bus when S_REQ_b[0] is asserted as the bus remains in idle state.</p>

13.2.4 Clock Signals

Table 21: Clock Signals

Signal Name	Type	Description
P_CLK	I	<p>Primary Bus: Input Clock</p> <p>The primary input clock is used for timing primary interface signals. The clock input ranges from 0-66 MHz.</p>
S_CLK	I	<p>Secondary Bus: Input Clock</p> <p>This is a low skew clock input for the Secondary Bus. The input ranges from 0-66MHz. The secondary clock input source can be asynchronous the primary clock. The secondary clock input can be generated by routing one of the S_CLK_O[9] clock signals back to the bridge. The user should ensure that the slot clocks and input S_CLK are well balanced.</p>
S_CLK_O[9:0]	O	<p>Secondary Bus: Output Clocks</p> <p>Signals S_CLK_O[9:0] are 10 clock outputs derived from the primary interface clock input, P_CLK. The secondary clocks are either same frequency as P_CLK or half the frequency as the primary input.</p> <p>The Tsi350A generates a divide by 2 clock when the S_M66EN pin is tied low and the P_M66EN input is high. The secondary output clocks can be disabled through the MSK_IN input during reset or by writing to the clock control register.</p>

13.2.5 Reset Signals

Table 22: Tsi350A Reset Signals

Signal Name	Type	Description
P_RST_b	I	<p>Primary Bus: Input Reset</p> <p>This is an active low system reset signal. When active, it clears all the internal state machines, registers and signals. When low the bridge drives the S_RST_b to reset the secondary devices.</p>
S_RST_b	O	<p>Secondary Bus: Output Reset</p> <p>S_RST_b will reset all devices that reside on the secondary PCI bus.</p> <p>Tsi350A asserts S_RST_b due to one of the following events:</p> <ul style="list-style-type: none"> • P_RST_b assertion - S_RST_b is asserted when P_RST_b is asserted on the primary interface of Tsi350A. The P_RST_b de-assertion triggers the serial mask shift operation for the secondary output clocks. Following the completion of mask shift operation, Tsi350A de-asserts S_RST_b after a 100 μs period. • Programming bit 6, Secondary Bus Reset, in the Bridge Control register (3Eh) - Software can force S_RST_b by programming this bit to '1'. The software should clear this bit to '0' to de-assert S_RST_b. Following the clear operation, the Tsi350A de-asserts S_RST_b after a 100 μs period. • Programming bit 0, Chip Reset, in the Diagnostic Control register (41h) - Software can program this bit to '1' to assert S_RST_b on the secondary interface. Tsi350A de-asserts S_RST_b automatically after 100 μs and clears the bit to '0'. <p>When Tsi350A asserts S_RST_b, it tri-states all secondary control signals and drives zeros on S_AD, S_CBE_b and S_PAR. Signal S_RST_b remains asserted until P_RST_b is de-asserted, the GPIO serial clock mask has been shifted in, and the secondary reset bit is clear. Assertion of S_RST_b by itself does not clear register state, and configuration registers are still accessible from the primary PCI interface.</p>

13.2.6 Miscellaneous Signals

Table 23: Tsi350A Miscellaneous Signals

Signal Name	Type	Description
MSK_IN	I	<p>Secondary clock disable serial input</p> <p>This input-only signal is used by the bridge when operating in synchronous mode to disable secondary clock outputs. This MSK_IN input is shifted after the de-assertion of P_RST_b. The mask bit determines the clocks to be disabled and the values are loaded into the Secondary Clock Control Register. The Tsi350A de-asserts the secondary reset after 100 μs of disabling the masked clock outputs. This input can be tied low to enable all secondary clock outputs, or tied high to drive all secondary clock outputs high.</p>
CONFIG66	I	<p>Configure 66 MHz operation</p> <p>This input only pin is used to specify if Tsi350A is capable of running at 66 MHz. If the pin is tied high, then the device can be run at 66 MHz. If the pin is tied low, then Tsi350A can only function under the 33 MHz PCI specification.</p>

Table 23: Tsi350A Miscellaneous Signals

Signal Name	Type	Description
P_M66EN	I	<p>Primary Bus: 66MHz Enable</p> <p>This signal indicates the operating speed of the primary interface in PCI mode. When pulled high, the primary interface operates at 66 MHz. When pulled low, the primary interface operates at 33 MHz.</p>
S_M66EN	I/OD	<p>Secondary Bus: 66MHz Enable</p> <p>This signal is Wire OR input of all the M66EN signals driven by secondary devices. The system operates at 66 MHz PCI, if this signal is pulled high. If the P_M66EN is tied low the bridge drives the S_M66EN low during reset.</p>
BPCCE	I	<p>Bus/power clock control management pin</p> <p>When signal BPCCE is tied high, and when Tsi350A is placed in the D3hot power state, it enables Tsi350A to place the secondary bus in the B2 power state. Tsi350A disables the secondary clocks and drives them to 0. When tied low, placing Tsi350A in the D3 hot power state has no effect on the secondary bus clocks.</p>
GPIO[3:0]/ HS_SWITCH_b	TS	<p>General Purpose Input Output</p> <p>The GPIOs are programmable input and output signals. The Tsi350A supports four GPIOs, which are independently controlled by software through the GPIO Output Enable control register, GPIO Output Data Register and GPIO Input Data register. Each GPIO can be programmed as input or output.</p> <p>General-purpose I/O terminal GPIO[3] is HS_SWITCH_b in CompactPCI mode. HS_SWITCH_b provides the status of the ejector handle switch to the CompactPCI logic.</p>
HS_ENUM_b	O	<p>Primary Bus: Hot Swap ENUM (PQFP package only)</p> <p>The Hot Swap ENUM is used when the bridge is configured for cPCI Hot Swap support. This pin is driven low when the bridge detects an event on HS_SWITCH_b, switch handle, indicating board insertion or extraction event by the user. This output interrupts the host for immediate attention.</p>
HS_LED	O	<p>Primary Bus: Compact PCI Hot Swap LED Output (PQFP package only)</p> <p>The signal is used to illuminate the Hot Swap Status LED associated with the board. The system software writes to LED bit in the Hot-Swap Control Status Register to control the LED status.</p> <p>If 0 = status LED is OFF If 1 = status LED is ON.</p>
MS1, MS0	I	<p>Mode Select Inputs</p> <p>These inputs are used to configure the bridge device for different modes of operation. The following summarizes the modes.</p> <p>MS0 = 0, MS1 = 1, Mode: Compact PCI hot-swap friendly <i>PCI Bus PM Interface Specification (Rev. 1.1)</i>, GPIO[3] functions as HS_SWITCH_b</p> <p>MS0 = 1, MS1 = X, Mode: Compact PCI hot-swap disabled <i>PCI Bus PM Interface Specification (Rev. 1.1)</i>, GPIO[3] functions as GPIO[3]</p> <p>MS0 = 0, MS1 = X, Mode: Compact PCI hot-swap disabled <i>PCI Bus PM Interface Specification (Rev. 1.1)</i>, GPIO[3] functions as GPIO[3]</p>

13.2.7 JTAG Signals

Table 24: JTAG Signals

Signal Name	Type	Description
TDI	I	JTAG serial data in Signal TDI is the serial input through which JTAG instructions and test data enter the JTAG interface. The new data on TDI is sampled on the rising edge of TCK. An un-terminated TDI produces the same result as if TDI were driven high.
TDO	O	JTAG serial data out Signal TDO is the serial output through which test instructions and data from the test logic leave the Tsi350A. This is a tri-state signal, enabled from the Test Access Port (TAP) controller.
TMS	I	JTAG test mode select Signal TMS causes state transitions in the test TAP controller. An un-driven TMS has the same result as if it were driven high.
TCK	I	JTAG boundary-scan clock Signal TCK is the clock controlling the JTAG logic.
TRST_b	I	JTAG TAP reset When asserted low, the TAP controller is asynchronously forced to enter a reset state, which in turn asynchronously initializes other test logic. An un-terminated TRST_b produces the same result as if it were driven high. TRST_b must be pulled to GND through a 100Ω resistor if the JTAG interface is unused.

13.2.8 Power and Ground Pins

Table 25: Power and Ground Pins

Signal Name	Type
VDD	+3.3V Power
VSS	Ground
P_VIO	Primary Interface I/O Voltage This pin provides the I/O voltage for the primary PCI interface. If a +5V PCI primary interface is implemented, then +5V power should be provided to this pin; if a +3.3V PCI primary interface is implemented, then +3.3V power should be provided to this pin.
S_VIO	Secondary Interface I/O Voltage This pin provides the I/O voltage for the secondary PCI interface. If a +5V PCI secondary interface is implemented, then +5V power should be provided to this pin; if a +3.3V PCI secondary interface is implemented, then +3.3V power should be provided to this pin.

13.3 Pinout

13.3.1 208-pin PQFP Pin List

Table 26: Tsi350A 208 Pin List

Pin	Signal Name
1	VDD
2	S_REQ_b[1]
3	S_REQ_b[2]
4	S_REQ_b[3]
5	S_REQ_b[4]
6	S_REQ_b[5]
7	S_REQ_b[6]
8	S_REQ_b[7]
9	S_REQ_b[8]
10	S_GNT_b[0]
11	S_GNT_b[1]
12	VSS
13	S_GNT_b[2]
14	S_GNT_b[3]
15	S_GNT_b[4]
16	S_GNT_b[5]
17	S_GNT_b[6]
18	S_GNT_b[7]
19	S_GNT_b[8]
20	VSS
21	S_CLK
22	S_RST_b
23	S_CFN_b
24	GPIO[3]/HS_SWITCH_b
25	GPIO[2]

Table 26: Tsi350A 208 Pin List

Pin	Signal Name
26	VDD
27	GPIO[1]
28	GPIO[0]
29	S_CLK_O[0]
30	S_CLK_O[1]
31	VSS
32	S_CLK_O[2]
33	S_CLK_O[3]
34	VDD
35	S_CLK_O[4]
36	S_CLK_O[5]
37	VSS
38	S_CLK_O[6]
39	S_CLK_O[7]
40	VDD
41	S_CLK_O[8]
42	S_CLK_O[9]
43	P_RST_b
44	BPCCE
45	P_CLK
46	P_GNT_b
47	P_REQ_b
48	VSS
49	P_AD[31]
50	P_AD[30]
51	VDD
52	VSS

Table 26: Tsi350A 208 Pin List

Pin	Signal Name
53	VDD
54	VSS
55	P_AD[29]
56	VDD
57	P_AD[28]
58	P_AD[27]
59	VSS
60	P_AD[26]
61	P_AD[25]
62	VDD
63	P_AD[24]
64	P_CBE_b[3]
65	P_IDSEL
66	VSS
67	P_AD[23]
68	P_AD[22]
69	VDD
70	P_AD[21]
71	P_AD[20]
72	VSS
73	P_AD[19]
74	P_AD[18]
75	VDD
76	P_AD[17]
77	P_AD[16]
78	VSS
79	P_CBE_b[2]

Table 26: Tsi350A 208 Pin List

Pin	Signal Name
80	P_FRAME_b
81	VDD
82	P_IRDY_b
83	P_TRDY_b
84	P_DEVSEL_b
85	P_STOP_b
86	VSS
87	P_LOCK_b
88	P_PERR_b
89	P_SERR_b
90	P_PAR
91	VDD
92	P_CBE_b[1]
93	P_AD[15]
94	VSS
95	P_AD[14]
96	P_AD[13]
97	VDD
98	P_AD[12]
99	P_AD[11]
100	VSS
101	P_AD[10]
102	P_M66EN
103	VDD
104	VSS
105	VDD
106	MS1

Table 26: Tsi350A 208 Pin List

Pin	Signal Name
107	P_AD[9]
108	VDD
109	P_AD[8]
110	P_CBE_b[0]
111	VSS
112	P_AD[7]
113	P_AD[6]
114	VDD
115	P_AD[5]
116	P_AD[4]
117	VSS
118	P_AD[3]
119	P_AD[2]
120	VDD
121	P_AD[1]
122	P_AD[0]
123	VSS
124	P_VIO
125	CONFIG66
126	MSK_IN
127	HS_ENUM_b
128	HS_LED
129	TDI
130	TDO
131	VDD
132	TMS
133	TCK

Table 26: Tsi350A 208 Pin List

Pin	Signal Name
134	TRST_b
135	S_VIO
136	VSS
137	S_AD[0]
138	S_AD[1]
139	VDD
140	S_AD[2]
141	S_AD[3]
142	VSS
143	S_AD[4]
144	S_AD[5]
145	VDD
146	S_AD[6]
147	S_AD[7]
148	VSS
149	S_CBE_b[0]
150	S_AD[8]
151	VDD
152	S_AD[9]
153	S_M66EN
154	S_AD[10]
155	MS0
156	VSS
157	VDD
158	VSS
159	S_AD[11]
160	VSS

Table 26: Tsi350A 208 Pin List

Pin	Signal Name
161	S_AD[12]
162	S_AD[13]
163	VDD
164	S_AD[14]
165	S_AD[15]
166	VSS
167	S_CBE_b[1]
168	S_PAR
169	S_SERR_b
170	VDD
171	S_PERR_b
172	S_LOCK_b
173	S_STOP_b
174	VSS
175	S_DEVSEL_b
176	S_TRDY_b
177	S_IRDY_b
178	VDD
179	S_FRAME_b
180	S_CBE_b[2]
181	VSS
182	S_AD[16]
183	S_AD[17]
184	VDD
185	S_AD[18]
186	S_AD[19]
187	VSS

Table 26: Tsi350A 208 Pin List

Pin	Signal Name
188	S_AD[20]
189	S_AD[21]
190	VDD
191	S_AD[22]
192	S_AD[23]
193	VSS
194	S_CBE_b[3]
195	S_AD[24]
196	VDD
197	S_AD[25]
198	S_AD[26]
199	VSS
200	S_AD[27]
201	S_AD[28]
202	VDD
203	S_AD[29]
204	S_AD[30]
205	VSS
206	S_AD[31]
207	S_REQ_b[0]
208	VDD

13.3.2 256-pin PBGA Pin List

Table 27: Tsi350A 256 Pin List

Pin	Signal Name
A2	S_REQ_b[2]
A4	S_AD[31]
A5	S_AD[28]
A6	S_AD[25]
A7	S_AD[22]
A8	S_AD[19]
A9	S_AD[17]
A10	S_FRAME_b
A11	S_DEVSEL_b
A12	S_PERR_b
A13	S_PAR
A14	S_AD[13]
A15	S_AD[11]
B3	S_REQ_b[1]
B4	S_REQ_b[0]
B5	S_AD[27]
B6	S_CBE_b[3]
B7	S_AD[21]
B8	S_AD[18]
B9	S_CBE_b[2]
B10	S_IRDY_b
B11	S_STOP_b
B12	S_CBE_b[1]
B13	S_AD[12]
B14	MS0
B16	S_AD[10]

Table 27: Tsi350A 256 Pin List

Pin	Signal Name
C1	S_REQ_b[5]
C2	S_REQ_b[4]
C5	S_AD[29]
C6	S_AD[24]
C7	S_AD[23]
C8	S_AD[20]
C9	S_AD[16]
C10	S_TRDY_b
C11	S_LOCK_b
C12	S_AD[15]
C16	S_AD[8]
D1	S_GNT_b[0]
D2	S_REQ_b[6]
D3	S_REQ_b[3]
D5	S_AD[30]
D6	S_AD[26]
D11	S_SERR_b
D12	S_AD[14]
D15	S_M66EN
D16	S_AD[6]
E1	S_GNT_b[3]
E2	S_GNT_b[2]
E3	S_REQ_b[7]
E4	S_REQ_b[8]
E13	S_AD[9]
E14	S_AD[7]
E15	S_CBE_b[0]

Table 27: Tsi350A 256 Pin List

Pin	Signal Name
E16	S_AD[4]
F1	S_GNT_b[7]
F2	S_GNT_b[6]
F3	S_GNT_b[1]
F4	S_GNT_b[4]
F13	S_AD[5]
F14	S_AD[3]
F15	S_AD[2]
F16	S_AD[1]
G1	S_GNT_b[8]
G3	S_GNT_b[5]
G14	S_VIO
G15	TRST_b
G16	S_AD[0]
H1	S_RST_b
H2	S_CFN_b
H3	S_CLKI
H14	TMS
H15	TCK
H16	TDO
J1	GPIO[1]
J2	GPIO[2]
J3	GPIO[3]
J15	TDI
K1	GPIO[0]
K2	S_CLK_O[0]
K3	S_CLK_O[1]

Table 27: Tsi350A 256 Pin List

Pin	Signal Name
K14	P_VIO
K15	MSK_IN
K16	CONFIG66
L1	S_CLK_O[2]
L2	S_CLK_O[3]
L3	S_CLK_O[5]
L4	S_CLK_O[6]
L13	P_AD[4]
L14	P_AD[2]
L15	P_AD[1]
L16	P_AD[0]
M1	S_CLK_O[4]
M2	S_CLK_O[8]
M3	S_CLK_O[9]
M4	P_CLK
M13	P_AD[6]
M14	P_AD[7]
M15	P_AD[5]
M16	P_AD[3]
N1	S_CLK_O[7]
N2	BPCCE
N3	P_AD[31]
N5	P_AD[28]
N6	P_AD[25]
N11	P_PAR
N12	P_AD[11]
N15	P_AD[8]

Table 27: Tsi350A 256 Pin List

Pin	Signal Name
N16	P_CBE_b[0]
P1	P_RST_b
P2	P_REQ_b
P5	P_AD[27]
P6	P_IDSEL
P7	P_AD[22]
P8	P_AD[18]
P9	P_FRAME_b
P10	P_DEVSEL_b
P11	P_SERR_b
P12	P_AD[14]
P16	P_AD[9]
R1	P_GNT_b
R5	P_AD[24]
R6	P_CBE_b[3]
R7	P_AD[20]
R8	P_AD[17]
R9	P_CBE_b[2]
R10	P_TRDY_b
R11	P_LOCK_b
R12	P_AD[15]
R13	P_AD[12]
R14	P_M66EN
R16	MS1
T2	P_AD[30]
T4	P_AD[29]
T5	P_AD[26]

Table 27: Tsi350A 256 Pin List

Pin	Signal Name
T6	P_AD[23]
T7	P_AD[21]
T8	P_AD[19]
T9	P_AD[16]
T10	P_IRDY_b
T11	P_STOP_b
T12	P_PERR_b
T13	P_CBE_b[1]
T14	P_AD[13]
T15	P_AD[10]

Table 28: Tsi350A 256 Pin List - Power, Ground, and Reserved

Name	Pin Number
VSS	A1, A16, B1, B2, B15, C3, C13, C14, D4, D13, D14, E5, E12, F6, F7, F8, F9, F10, F11, G2, G6, G7, G8, G9, G10, G11, H6, H7, H8, H9, H10, H11, J6, J7, J8, J9, J10, J11, K6, K7, K8, K9, K10, K11, L6, L7, L8, L9, L10, L11, M5, M12, N4, N13, N14, P3, P4, P14, R2, R4, R15, T1, T16
VDD	A3, C4, C15, D7, D8, D9, D10, E6, E7, E8, E9, E10, E11, F5, F12, G4, G5, G12, G13, H4, H5, H12, H13, J4, J5, J12, J13, K4, K5, K12, K13, L5, L12, M6, M7, M8, M9, M10, M11, N7, N8, N9, N10, P13, P15, R3, T3
Reserved	J14, J16

14. Electrical Characteristics

This chapter discusses the following:

- “Absolute Maximum Ratings” on page 119
- “Recommended Operating Conditions” on page 119
- “Power Characteristics” on page 120
- “DC Specifications” on page 120
- “AC Timing Specifications” on page 122

14.1 Absolute Maximum Ratings

The following tables contain the absolute maximum ratings for the Tsi350A.

Table 29: Absolute Maximum Ratings

Symbol	Parameter	Minimum	Maximum	Units
T_{STG}	Storage temperature	-40	125	°C
T_C	Case temperature under bias	-40	120	°C
Voltage with respect to ground				
V_{DD}	Supply voltage	3.0	3.63	V
V_{IL}	Minimum signal input voltage	-0.5	-	V
V_{IH}	Maximum signal input voltage	-	$V_{DD} + 0.5V$	V

14.2 Recommended Operating Conditions

The following table contains the recommended operating conditions for the Tsi350A.

Table 30: Recommended Operating Conditions

Symbol	Parameter	Minimum	Maximum	Units	Notes
V_{DD}	Supply voltage	3.0	3.6	V	-
T_A	Ambient temperature	0.0	85	°C	^a
T_{JUNC}	Junction temperature	0.0	125	°C	-

a. No heat sink, no air flow.

14.3 Power Characteristics

The following table contains power characteristics for the Tsi350A. The value was measured in a typical configuration, including:

- Primary PCI Bus: 66 MHz
- Secondary PCI Bus: 66 MHz
- Primary PCI bus loading: Two
- Secondary PCI bus loading: Two.

Table 31: Power Characteristics

Symbol	Parameter	Typical	Units	Notes
Power Consumption				
P _{TOTAL}	Total device power	1.2	W	-

14.4 Power Supply Sequencing

The Tsi350A has only one voltage domain, so no special power sequencing is required.

14.5 DC Specifications

Table 32 defines the DC parameters met by all Tsi350A signals under the conditions of the functional operating range.

Table 32: Tsi350A DC Specifications

Symbol	Parameter	Condition	Exceptions ^a	Minimum	Maximum	Unit
V _{IL}	Low-level input voltage	-	-	-0.5	0.3V _{DD}	V
V _{IH}	High-level input voltage	-	-	0.5V _{DD}	V _{DD} + 0.5V	V
		-	P_RST_b	0.6V _{DD}	V _{DD} + 0.5V	V
		-	P_CLK	0.6V _{DD}	V _{DD} + 0.5V	V
		-	TRST_b	0.6V _{DD}	V _{DD} + 0.5V	V
V _{OL} (5V)	Low-level output voltage	I _{OUT} = 6 mA	-	-	0.55	V
V _{OH}	High-level output voltage	I _{OUT} = -500 μA	-	0.9V _{DD}	-	V
V _{OH} (5V)	High-level output voltage	I _{OUT} = 2 mA	-	2.4	-	V
I _{IL}	Low-level input leakage current	0 < V _{IN} < V _{DD}	-	-	±10	μA
C _{IN}	Input pin capacitance	-	-	-	10	pF

Table 32: Tsi350A DC Specifications

Symbol	Parameter	Condition	Exceptions ^a	Minimum	Maximum	Unit
C _{IDSEL}	P_IDSEL pin capacitance	-	-	-	8	pF
C _{CLK}	P_CLK, S_CLK pin capacitance	-	-	5	12	pF

a. These signals have special parameters for V_{IH} .

14.6 AC Timing Specifications

Figure 7, Table 33, and Table 34 show the PCI signal timing specifications.

Figure 7: PCI Signal Timing Measurement Conditions

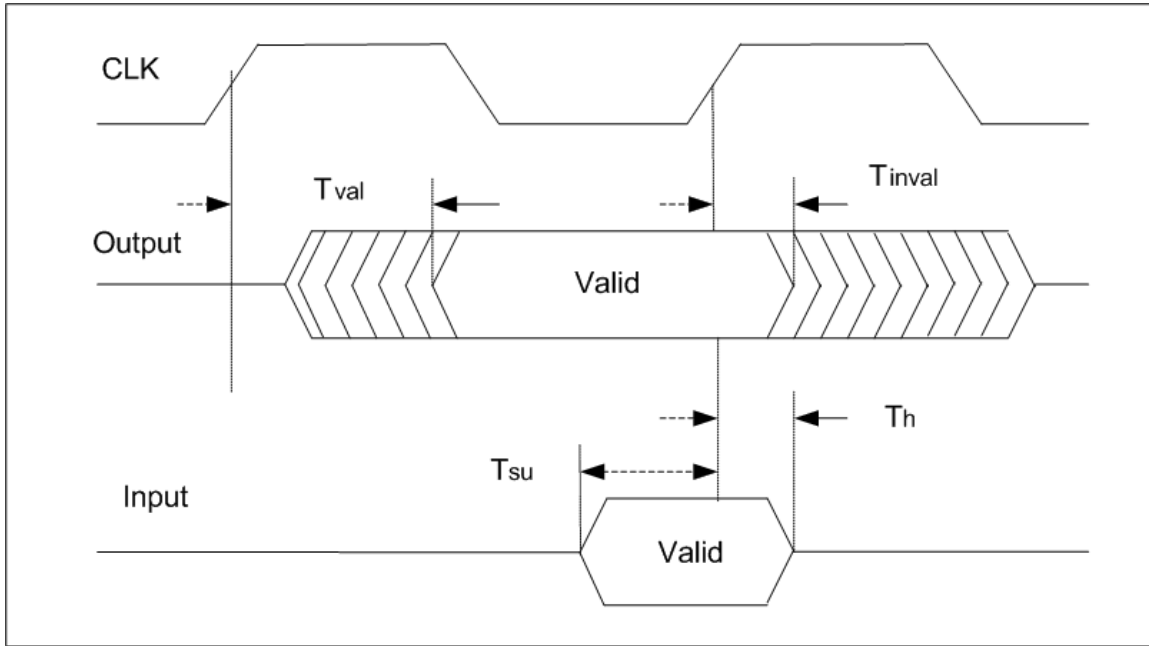

Table 33: 33 MHz PCI Signal Timing

Symbol	Parameter	Minimum	Maximum
T_{VAL}	CLK to signal valid delay	2 ns	11 ns
$T_{VAL}(ptp)$	CLK to signal valid delay (point-to-point)	2 ns	12 ns
T_{SU}	Input setup time (bused signals)	7 ns	-
$T_{SU}(ptp)$	Input setup time to CLK (point-to-point)	10 ns, 12 ns	-
T_H	Input signal hold time from CLK	0 ns	-

Table 34: 66 MHz PCI Signal Timing

Symbol	Parameter	Minimum	Maximum
T_{VAL}	CLK to signal valid delay	2 ns	6 ns
$T_{VAL}(ptp)$	CLK to signal valid delay (point-to-point)	2 ns	6 ns
T_{SU}	Input setup time (bused signals)	3 ns	-
$T_{SU}(ptp)$	Input setup time to CLK (point-to-point)	5 ns	-
T_H	Input signal hold time from CLK	0 ns	-

15. Registers

This chapter discusses the following:

- “Overview of Registers” on page 125
- “PCI-to-PCI Bridge Standard Configuration Registers” on page 128
- “Device-Specific Configuration Registers” on page 151

15.1 Overview of Registers

This chapter provides a detailed description of Tsi350A configuration space registers. The chapter is divided into the following sections: “PCI-to-PCI Bridge Standard Configuration Registers” on page 128 describes the standard Tsi350A PCI-to-PCI bridge configuration registers, and “Device-Specific Configuration Registers” on page 151 describes Tsi350A device-specific configuration registers.

Tsi350A configuration space uses the PCI-to-PCI bridge standard format specified in the *PCI-to-PCI Bridge Architecture Specification*. The header type at configuration address 0x0E reads as 0x01, indicating that this device uses the PCI-to-PCI bridge format.

Tsi350A also contains device-specific registers, starting at address 40h. Use of these registers is not required for standard PCI-to-PCI bridge implementations.

The configuration space registers can be accessed only from the primary PCI bus. To access a register, perform a Type 0 format configuration read or write operation to that register. During the Type 0 address phase, P_AD[7:2] indicates the Dword offset of the register. During the data phase, P_CBE_b[3:0] selects the bytes in the Dword that is being accessed.



Software changes the configuration register values that affect Tsi350A behavior only during initialization. Change these values subsequently only when both the primary and secondary PCI buses are idle, and the data buffers are empty; otherwise, the behavior of Tsi350A is unpredictable.

Table 35: Tsi350A Configuration Space

Register Names				Starting Address
Bits 31:24	Bits 23:16	Bits 15:8	Bits 7:0	
Device ID		Vendor ID		0x00
Primary Status Register		Primary Command Register		0x04
Class Code			Revision ID	0x08

Table 35: Tsi350A Configuration Space

Register Names				Starting Address
Bits 31:24	Bits 23:16	Bits 15:8	Bits 7:0	
BIST	Header Type	Primary Latency Timer	Cache Line Size	0x0C
Reserved				0x10
Reserved				0x14
Secondary latency timer	Subordinate Bus Number	Secondary Bus Number	Primary Bus Number	0x18
Secondary Status		I/O Limit	I/O Base	0x1C
Memory Limit Address		Memory Base Address		0x20
Prefetchable Memory Limit		Prefetchable Memory Base		0x24
Prefetchable Memory Base Upper 32 Bits				0x28
Prefetchable Memory Limit Upper 32 Bits				0x2C
I/O Limit Upper 16 Bits		I/O Base Upper 16 Bits		0x30
Reserved			ECP Pointer	0x34
Reserved				0x38
Bridge Control		Interrupt Pin	Reserved	0x3C
Arbiter Control		Diagnostic Control	Chip Control	0x40
Reserved			Non-posted flush	0x44
Reserved				0x4h-0x60
GPIO Input Data	GPIO Output Enable Control	GPIO Output Data	P_SERR_b Event Disable	0x64
Reserved	P_SERR_b Status	Secondary Clock Control		0x68
Reserved				0x6C-0xDB
Power Management Capabilities		Next Item Ptr	Capability ID	0xDC
Data	PPB Support Extensions	Power Management CSR		0xE0
Reserved	Hot Swap control status	HS Next Item pointer	HS Capability ID	0xE4

15.1.1 Reserved Register Addresses and Fields

Reserved register addresses should not be read or written. Reads to reserved register addresses will return unspecified data. Writes to reserved register addresses may lead to unpredictable results.

Reserved fields within registers return undefined data when read. Reserved fields should always be written as 0 unless noted otherwise.

Table 36 shows the defined register access types.

Table 36: Register Access Types

Abbreviation	Description
R	Read Only
R/W	Read or Write
R/W1C	Readable. Write 1 to Clear
R/W1S	Readable. Write 1 to Set. Writing a 1 triggers an event, bit reads as 0.

15.2 PCI-to-PCI Bridge Standard Configuration Registers

This section provides a detailed description of the PCI-to-PCI bridge standard configuration registers.

Fields that have the same configuration Dword address are selectable by turning on (driving low) the appropriate byte enable bits on P_CBE_b during the data phase. To select all fields of a configuration address, drive all byte enable bits low.

All reserved fields and registers are read only and always return zero.

15.2.1 Vendor ID Register—Offset 0x00

- Dword address = 0x00
- Byte enable P_CBE_b[3:0] = xx00b

Bit	Name	Type	Description	Reset value
15:0	Vendor ID	R	This 16-bit read only field contains the Vendor ID, which identifies the vendor of the device. Internally hardwired to be 0x1011	0x1011

15.2.2 Device ID Register—Offset 0x00

- Dword address = 0x00
- Byte enable P_CBE_b[3:0] = 00xxb

Bit	Name	R/W	Description	Reset Value
31:16	Device ID	R	This 16-bit read only field contains the Device ID, which identifies the vendor of the device. Internally hardwired to be 0x0023.	0x0023

15.2.3 Primary Command Register—Offset 0x04

These bits affect the behavior of Tsi350A primary interface, except where noted. Some of the bits are repeated in the bridge control register, to act on the secondary interface.

This register must be initialized by configuration software.

- Dword address = 0x04
- Byte enable P_CBE_b[3:0] = xx00b

Bit	Name	Type	Description	Reset Value
0	I/O space enable	R/W	Controls Tsi350A's response to I/O transactions on the primary interface. 0 = Tsi350A does not respond to I/O transactions initiated on the primary bus. 1 = Tsi350A response to I/O transactions initiated on the primary bus is enabled. Reset value: 0.	0
1	Memory space enable	R/W	Controls Tsi350A's response to memory transactions on Tsi350A primary interface. 0 = Tsi350A does not respond to memory transactions initiated on the primary bus. 1 = Tsi350A response to memory transactions initiated on the primary bus is enabled. Reset value: 0.	0
2	Master enable	R/W	Controls Tsi350A's ability to initiate memory and I/O transactions on the primary bus on behalf of an initiator on the secondary bus. Forwarding of configuration transactions is not affected. 0 = Tsi350A does not respond to I/O or memory transactions on the secondary interface and does not initiate I/O or memory transactions on the primary interface. 1 = Tsi350A is enabled to operate as an initiator on the primary bus and responds to I/O and memory transactions initiated on the secondary bus. Reset value: 0.	0
3	Special cycle enable	R	Tsi350A ignores special cycle transactions, so this bit is read only and returns 0.	0
4	Memory write and invalidate enable	R	Tsi350A generates memory write and invalidate transactions only when operating on behalf of another master whose memory write and invalidate transaction is crossing Tsi350A. This bit is read only and returns 0.	0

Bit	Name	Type	Description	Reset Value
5	VGA snoop enable	R/W	<p>Controls Tsi350A's response to VGA compatible palette write transactions. VGA palette write transactions correspond to I/O transactions whose address bits are as follows:</p> <ul style="list-style-type: none"> • P_AD[9:0] are equal to 3C6h, 3C8h, and 3C9h. • P_AD[15:10] are not decoded. • P_AD[31:16] must be 0. <p>0 = VGA palette write transactions on the primary interface are ignored unless they fall inside Tsi350A's I/O address range.</p> <p>1 = VGA palette write transactions on the primary interface are positively decoded and forwarded to the secondary interface.</p> <p>Reset value: 0.</p>	0
6	Parity error response	R/W	<p>Controls Tsi350A's response when a parity error is detected on the primary interface.</p> <p>0 = Tsi350A does not assert P_PERR_b, nor does it set the data parity reported bit in the status register. Tsi350A does not report address parity errors by asserting P_SERR_b.</p> <p>1 = Tsi350A drives P_PERR_b and conditionally sets the data parity reported bit in the status register when a data parity error is detected (see Section 7). Tsi350A allows P_SERR_b assertion when address parity errors are detected on the primary interface.</p> <p>Reset value: 0.</p>	0
7	Wait cycle control	R	<p>Reads as 0 to indicate that Tsi350A does not perform address or data stepping.</p>	0
8	SERR_b enable	R/W	<p>Controls the enable for P_SERR_b on the primary interface.</p> <p>0=Signal P_SERR_b cannot be driven by Tsi350A.</p> <p>1 = Signal P_SERR_b can be driven low by Tsi350A under the conditions described in Section 7.</p> <p>Reset value: 0.</p>	0
9	Fast back-to-back enable	R	<p>Reads as 0 to indicate that Tsi350A does not generate fast back-to-back transactions on the primary bus.</p>	0
15:10	Reserved	R	<p>Reserved. Returns 0 when read.</p>	0

15.2.4 Primary Status Register—Offset 0x04

These bits affect the status of Tsi350A primary interface. Bits reflecting the status of the secondary interface are found in the secondary status register.

- Dword address = 0x04
- Byte enable P_CBE_b[3:0] = 00xxb

Bit	Name	Type	Description	Reset value
19:16	Reserved	R	Reserved. Returns 0 when read.	0
20	ECP	R	Enhanced Capabilities Port (ECP) enable. Reads as 1 in Tsi350A to indicate that Tsi350A supports an enhanced capabilities list.	1
21	66-MHz capable	R	Indicates whether the primary interface is 66-MHz capable. Reads as 0 when pin CONFIG66 is tied low to indicate that Tsi350A is not 66 MHz capable. Reads as 1 when pin CONFIG66 is tied high to indicate that the primary bus is 66 MHz capable.	Undefined
22	Reserved	R	Reserved. Returns 0 when read.	0
23	Fast back-to-back capable	R	Reads as 1 to indicate that Tsi350A is able to respond to fast back-to-back transactions on the primary interface.	1
24	Data parity detected	R/W1C	This bit is set to 1 when all of the following are true: - Tsi350A is a master on the primary bus. - Signal P_PERR_b is detected asserted, or a parity error is detected on the primary bus. - The parity error response bit is set in the command register. Reset value: 0.	0
26:25	DEVSEL_b timing	R	Indicates slowest response to a non-configuration command on the primary interface. Reads as 01b to indicate that Tsi350A responds no slower than with medium timing.	1
27	Signaled target abort	R/W1C	This bit is set to 1 when Tsi350A is acting as a target on the primary bus and returns a target abort to the primary master. Reset value: 0.	0
28	Received target abort	R/W1C	This bit is set to 1 when Tsi350A is acting as a master on the primary bus and receives a target abort from the primary target. Reset value: 0.	0
29	Received master abort	R/W1C	This bit is set to 1 when Tsi350A is acting as a master on the primary bus and receives a master abort. Reset value: 0.	0

Bit	Name	Type	Description	Reset value
30	Signaled system error	R/W1C	This bit is set to 1 when Tsi350A has asserted P_SERR_b. Reset value: 0.	0
31	Detected parity error	R/W1C	This bit is set to 1 when Tsi350A detects an address or data parity error on the primary interface. Reset value: 0.	0

15.2.5 Revision ID Register—Offset 0x08

- Dword address = 0x08
- Byte enable P_CBE_b[3:0] = xxx0b

Bit	Name	Type	Description	Reset value
7:0	Revision ID	R	Indicates the revision number of this device. The initial revision reads as 0x60.	0x60

15.2.6 Programming Interface Register—Offset 0x08

- Dword address = 0x08
- Byte enable P_CBE_b[3:0] = xx0xb

Bit	Name	Type	Description	Reset value
15:8	Programming interface	R	No programming interfaces have been defined for PCI-to-PCI bridges. Reads as 0.	0

15.2.7 Subclass Code Register—Offset 0x08

- Dword address = 0x08
- Byte enable P_CBE_b[:0] = x0xxb

Bit	Name	Type	Description	Reset value
23:16	Subclass code	R	Reads as 0x04 to indicate that this bridge device is a PCI-to-PCI bridge.	0x04

15.2.8 Base Class Code Register—Offset 0x08

- Dword address = 0x08
- Byte enable P_CBE_b[3] = 0xxx

Bit	Name	Type	Description	Reset value
31:24	Base class code	R	Reads as 0x06 to indicate that this bridge device is a bridge device.	0x06

15.2.9 Cache Line Size Register—Offset 0x0C

- Dword address = 0x0C
- Byte enable P_CBE_b[3:0] = xxx0b

Bit	Name	Type	Description	Reset value
7:0	Cache line size	R/W	Designates the cache line size for the system in units of 32-bit Dwords. Used for prefetching memory read transactions and for terminating memory write and invalidate transactions. The cache line size should be written as a power of 2. If the value is not a power of 2 or is greater than 16, Tsi350A behaves as if the cache line size were 16 Dwords. Reset value: 0.	0

15.2.10 Primary Latency Timer Register—Offset 0x0C

- Dword address = 0x0C
- Byte enable P_CBE_b[3:0] = xx0xb

Bit	Name	Type	Description	Reset value
15:8	Master latency timer	R/W	Master latency timer for the primary interface. Indicates the number of PCI clock cycles from the assertion of P_FRAME_b to the expiration of the timer when Tsi350A is acting as a master on the primary interface. All bits are writable, resulting in a granularity of one PCI clock cycle. 0 = Tsi350A relinquishes the bus after the first data transfer when Tsi350A's primary bus grant has been de-asserted, with the exception of memory write and invalidate transactions. Reset value: 0.	0

15.2.11 Header Type Register—Offset 0x0C

- Dword address = 0x0C
- Byte enable P_CBE_b[3:0] = x0xxb

Bit	Name	Type	Description	Reset value
23:16	Header type	R	Defines the layout of addresses 10h through 3Fh in configuration space. Reads as 0x01 to indicate that the register layout conforms to the standard PCI-to-PCI bridge layout.	0x01

15.2.12 Primary Bus Number Register—Offset 0x18

This register must be initialized by configuration software.

- Dword address = 0x18
- Byte enable P_CBE_b[3:0] = xxx0b

Bit	Name	Type	Description	Reset value
7:0	Primary bus number	R/W	Indicates the number of the PCI bus to which the primary interface is connected. Tsi350A uses this register to decode Type 1 configuration transactions on the secondary interface that should either be converted to special cycle transactions on the primary interface or passed upstream unaltered. Reset value: 0.	0

15.2.13 Secondary Bus Number Register—Offset 0x18

This register must be initialized by configuration software.

- Dword address = 0x18
- Byte enable P_CBE_b[3:0]= xx0xb

Bit	Name	Type	Description	Reset value
15:8	Secondary bus number	R/W	Indicates the number of the PCI bus to which the secondary interface is connected. Tsi350A uses this register to determine when to respond to and forward Type 1 configuration transactions on the primary interface, and to determine when to convert them to Type 0 or special cycle transactions on the secondary interface. Reset value: 0.	0

15.2.14 Subordinate Bus Number Register—Offset 0x18

This register must be initialized by configuration software.

- Dword address = 0x18
- Byte enable P_CBE_b[3:0]= x0xxb

Bit	Name	Type	Description	Reset value
23:16	Subordinate bus number	R/W	Indicates the number of the highest numbered PCI bus that is behind (or subordinate to) Tsi350A. Used in conjunction with the secondary bus number to determine when to respond to Type 1 configuration transactions on the primary interface and pass them to the secondary interface as a Type 1 configuration transaction. Reset value: 0.	0

15.2.15 Secondary Latency Timer Register—Offset 0x18

- Dword address = 0x18
- Byte enable P_CBE_b[3:0] = 0xxxb

Bit	Name	Type	Description	Reset value
31:24	Secondary latency timer	R/W	Master latency timer for the secondary interface. Indicates the number of PCI clock cycles from the assertion of S_FRAME_b to the expiration of the timer when Tsi350A is acting as a master on the secondary interface. All bits are writable, resulting in a granularity of one PCI clock cycle. 0 = Tsi350A ends the transaction after the first data transfer when Tsi350A's secondary bus grant has been de-asserted, with the exception of memory write and invalidate transactions. Reset value: 0.	0

15.2.16 I/O Base Address Register—Offset 0x1C

This register must be initialized by configuration software.

- Dword address = 0x1C
- Byte enable P_CBE_b[3:0] = xxx0b

Bit	Name	Type	Description	Reset value
3:0	32-bit indicator	R	The low 4 bits of this register read as 0x1 to indicate that Tsi350A supports 32-bit I/O address decoding.	0x1
7:4	I/O base address [15:12]	R/W	Defines the bottom address of an address range used by Tsi350A to determine when to forward I/O transactions from one interface to the other. The upper 4 bits are writeable and correspond to address bits [15:12]. The lower 12 bits of the address are assumed 0. The upper 16 bits corresponding to address bits [31:16] are defined in the I/O base address upper 16 bits register. The I/O address range adheres to 4 kB alignment and granularity. Reset value: 0.	0

15.2.17 I/O Limit Address Register—Offset 0x1C

This register must be initialized by configuration software.

- Dword address = 0x1C
- Byte enable P_CBE_b[3:0] = xx0xb

Bit	Name	Type	Description	Reset value
11:8	32-bit indicator	R	The low 4 bits of this register read as 1h to indicate that Tsi350A supports 32-bit I/O address decoding.	0x1
15:12	I/O base address[15:12]	R/W	Defines the top address of an address range used by Tsi350A to determine when to forward I/O transactions from one interface to the other. The upper 4 bits are writable and correspond to address bits [15:12]. The lower 12 bits of the address are assumed 0. The upper 16 bits corresponding to address bits [31:16] are defined in the I/O base address upper 16 bits register. The I/O address range adheres to 4 kB alignment and granularity. Reset value: 0.	0

15.2.18 Secondary Status Register—Offset 0x1C

These bits reflect the status of Tsi350A secondary interface. W1C indicates that writing 1 to that bit sets the bit to 0. Writing 0 has no effect.

- Dword address = 0x1C
- Byte enable P_CBE_b[3:0] = 00xxb

Bit	Name	Type	Description	Reset Value
20:16	Reserved	R	Reserved. Returns 0 when read.	0
21	66-MHz capable	R	Indicates whether the secondary interface is 66-MHz capable. Reads as 0 when pin CONFIG66 is tied low to indicate that Tsi350A is not 66 MHz capable. Reads as 1 when pin CONFIG66 is tied high to indicate that the primary bus is 66 MHz capable.	Undefined
22	Reserved	R	Reserved. Returns 0 when read.	0
23	Fast back-to-back capable	R	Reads as 1 to indicate that Tsi350A is able to respond to fast back-to-back transactions on the secondary interface.	1
24	Data parity detected	R/W1C	This bit is set to 1 when all of the following are true: Tsi350A is a master on the secondary bus. Signal S_PERR_b is detected asserted, or a parity error is detected on the primary bus. The parity error response bit is set in the bridge control register. Reset value: 0.	0
26:25	DEVSEL_b timing	R	Indicates slowest response to a non-configuration command on the secondary interface. Reads as 01b to indicate that Tsi350A responds no slower than with medium timing.	01
27	Signaled target abort	R/W1C	This bit is set to 1 when Tsi350A is acting as a target on the secondary bus and returns a target abort to the secondary bus master. Reset value: 0.	0
28	Received target abort	R/W1C	This bit is set to 1 when Tsi350A is acting as a master on the secondary bus and receives a target abort from the secondary bus target. Reset value: 0.	0
29	Received master abort	R/W1C	This bit is set to 1 when Tsi350A is acting as an initiator on the secondary bus and receives a master abort. Reset value: 0.	0

Bit	Name	Type	Description	Reset Value
30	Received system error	R/W1C	This bit is set to 1 when Tsi350A detects the assertion of S_SERR_b on the secondary interface. Reset value: 0.	0
31	Detected parity error	R/W1C	This bit is set to 1 when Tsi350A detects an address or data parity error on the secondary interface. Reset value: 0.	0

15.2.19 Memory Base Address Register—Offset 0x20

This register must be initialized by configuration software.

Dword address = 0x20

Byte enable P_CBE_b[3:0] = xx00b

Bit	Name	Type	Description	Reset value
3:0	Reserved	R	The lower 4 bits of this register are read only and return 0.	0
15:4	Memory base address [31:20]	R/W	Defines the bottom address of an address range used by Tsi350A to determine when to forward memory transactions from one interface to the other. The upper 12 bits are writable and correspond to address bits [31:20]. The lower 20 bits of the address are assumed to be 0. The memory address range adheres to 1MB alignment and granularity. Reset value: 0.	0

15.2.20 Memory Limit Address Register—Offset 0x20

This register must be initialized by configuration software.

- Dword address = 0x20
- Byte enable P_CBE_b[3:0] = 00xxb

Bit	Name	Type	Description	Reset value
19:16	Reserved	R	The lower 4 bits of this register are read only and return 0.	0
31:20	Memory limit address [31:20]	R/W	Defines the top address of an address range used by Tsi350A to determine when to forward memory transactions from one interface to the other. The upper 12 bits are writable and correspond to address bits [31:20]. The lower 20 bits of the address are assumed 0xFFFF. The memory address range adheres to 1 MB alignment and granularity. Reset value: 0.	0

15.2.21 Prefetchable Memory Base Address Register—Offset 0x24

This register must be initialized by configuration software.

- Dword address = 0x24
- Byte enable P_CBE_b[3:0] = xx00b

Bit	Name	Type	Description	Reset value
3:0	64-bit indicator	R	The low 4 bits of this register are read only and return 1h to indicate that this range supports 64-bit addressing.	0x1
15:4	Prefetchable memory base address [31:20]	R/W	Defines the bottom address of an address range used by Tsi350A to determine when to forward memory read and write transactions from one interface to the other. The upper 12 bits are writable and correspond to address bits [31:20]. The lower 20 bits of the address are assumed 0. The memory base register upper 32 bits contain the upper half of the base address. The memory address range adheres to 1 MB alignment and granularity. Reset value: 0.	0

15.2.22 Prefetchable Memory Limit Address Register—Offset 0x24

This register must be initialized by configuration software.

- Dword address = 0x24
- Byte enable P_CBE_b[3:0] = 00xxb

Bit	Name	Type	Description	Reset value
19:16	64-bit indicator	R	The low 4 bits of this register are read only and return 1h to indicate that this range supports 64-bit addressing.	0x1
31:20	Prefetchable memory limit address [31:20]	R/W	Defines the top address of an address range used by Tsi350A to determine when to forward memory read and write transactions from one interface to the other. The upper 12 bits are writable and correspond to address bits [31:20]. The lower 20 bits of the address are assumed to be FFFFh. The memory limit upper 32 bits register contains the upper half of the limit address. The memory address range adheres to 1MB alignment and granularity. Reset value: 0.	0

15.2.23 Prefetchable Memory Base Address Upper 32 Bits Register—Offset 0x28

This register must be initialized by configuration software.

- Dword address = 0x28
- Byte enable P_CBE_b[3:0]= 0000b

Bit	Name	Type	Description	Reset value
31:0	Upper 32 prefetchable memory base address [63:32]	R/W	Defines the upper 32 bits of a 64-bit bottom address of an address range used by Tsi350A to determine when to forward memory read and write transactions from one interface to the other. The memory address range adheres to 1 MB alignment and granularity. Reset value: 0.	0

15.2.24 Prefetchable Memory Limit Address Upper 32 Bits Register—Offset 0x2C

This register must be initialized by configuration software.

- Dword address = 0x2C
- Byte enable P_CBE_b[3:0] = 0000b

Bit	Name	Type	Description	Reset value
31:0	Upper 32 prefetchable memory limit address [63:32]	R/W	Defines the upper 32 bits of a 64-bit top address of an address range used by the Tsi350A to determine when to forward memory read and write transactions from one interface to the other. Extra read transactions should have no side effects. The memory address range adheres to 1 MB alignment and granularity. Reset value: 0.	0

15.2.25 I/O Base Address Upper 16 Bits Register—Offset 0x30

This register must be initialized by configuration software.

- Dword address = 0x30
- Byte enable P_CBE_b[3:0] = xx00b

Bit	Name	Type	Description	Reset value
15:0	I/O base address upper 16 bits [31:16]	R/W	Defines the upper 16 bits of a 32-bit bottom address of an address range used by Tsi350A to determine when to forward I/O transactions from one interface to the other. The I/O address range adheres to 4 kB alignment and granularity. Reset value: 0.	0

15.2.26 I/O Limit Address Upper 16 Bits Register—Offset 0x30

This register must be initialized by configuration software.

- Dword address = 0x30
- Byte enable P_CBE_b[3:0] = 00xxb

Bit	Name	Type	Description	Reset value
31:16	I/O limit address upper 16 bits [31:16]	R/W	Defines the upper 16 bits of a 32-bit top address of an address range used by Tsi350A to determine when to forward I/O transactions from one interface to the other. The I/O address range adheres to 4 kB alignment and granularity. Reset value: 0.	0

15.2.27 ECP Pointer Register—Offset 0x34

- Dword address = 0x34
- Byte enable P_CBE_b[3:0] = 0000b

Bit	Name	Type	Description	Reset value
7:0	ECP_PTR	R	Enhanced Capabilities Port (ECP) offset pointer. Reads as 0xDC in Tsi350A to indicate that the first item, which corresponds to the power management registers, resides at that configuration offset.	0xDC
31:8	Reserved	R	Reserved. Return 0 when read.	0

15.2.28 Interrupt Pin Register—Offset 0x3C

- Dword address = 0x3C
- Byte enable P_CBE_b[3:0] = xx0xb

Bit	Name	Type	Description	Reset value
15:8	Interrupt pin	R	Reads as 0 to indicate that Tsi350A does not have an interrupt pin.	0

15.2.29 Bridge Control Register—Offset 0x3C

This register must be initialized by configuration software.

- Dword address = 0x3C
- Byte enable P_CBE_b[3:0]= 00xxb

Bit	Name	Type	Description	Reset value
16	Parity error response	R/W	Controls Tsi350A's response when a parity error is detected on the secondary interface. 0 = Tsi350A does not assert S_PERR_b, nor does it set the data parity reported bit in the secondary status register. Tsi350A does not report address parity errors by asserting P_SERR_b. 1 = Tsi350A drives S_PERR_b and conditionally sets the data parity reported bit in the secondary status register when a data parity error is detected on the secondary interface (see Section 7.0). Also must be set to 1 to allow P_SERR_b assertion when address parity errors are detected on the secondary interface. Reset value: 0.	0
17	SERR_b forward enable	R/W	Controls whether Tsi350A asserts P_SERR_b when it detects S_SERR_b asserted. 0 = Tsi350A does not drive P_SERR_b in response to S_SERR_b assertion. 1 = Tsi350A asserts P_SERR_b. when S_SERR_b is detected asserted (the primary SERR_b driver enable bit must also be set). Reset value 0.	0
18	ISA enable	R/W	Modifies Tsi350A's response to ISA I/O addresses. Applies only to those addresses falling within the I/O base and limit address registers and within the first 64 kB of PCI I/O space. 0 = Tsi350A forwards all I/O transactions downstream that fall within the I/O base and limit address registers. 1 = Tsi350A ignores primary bus I/O transactions within the I/O base and limit address registers and within the first 64 kB of PCI I/O space that address the last 768 bytes in each 1 kB block. Secondary bus I/O transactions are forwarded upstream if the address falls within the last 768 bytes in each 1 kB block. Reset value: 0.	0

Bit	Name	Type	Description	Reset value
19	VGA enable	R/W	<p>Modifies Tsi350A's response to VGA compatible addresses.</p> <p>0 = VGA transactions are ignored on the primary bus unless they fall within the I/O base and limit address registers and the ISA mode is 0.</p> <p>1 = Tsi350A positively decodes and forwards the following transactions downstream, regardless of the values of the I/O base and limit registers, ISA mode bit, or VGA snoop bit:</p> <p>Memory transactions addressing 0x000A0000–0x000BFFFFh</p> <p>I/O transactions addressing:</p> <ul style="list-style-type: none"> • P_AD[9:0] = 3B0h–3BBh and 3C0h–3DFh • P_AD[15:10] are not decoded. • P_AD[31:16] = 0000h. <p>I/O and memory space enable bits must be set in the command register.</p> <p>The transactions listed here are ignored by Tsi350A on the secondary bus.</p> <p>Reset value: 0.</p>	0
20	Reserved	R	Reserved. Returns 0 when read.	0
21	Master abort mode	R/W	<p>Controls Tsi350A's behavior when a master abort termination occurs in response to a transaction initiated by Tsi350A on either the primary or secondary PCI interface.</p> <p>0 = Tsi350A asserts TRDY_b on the initiator bus for delayed transactions, and FFFF FFFFh for read transactions. For posted write transactions, P_SERR_b is not asserted.</p> <p>1 = Tsi350A returns a target abort on the initiator bus for delayed transactions. For posted write transactions, Tsi350A asserts P_SERR_b if the SERR_b enable bit is set in the command register.</p> <p>Reset value: 0.</p>	0
22	Secondary bus reset	R/W	<p>Controls S_RST_b on the secondary interface.</p> <p>0 = Tsi350A de-asserts S_RST_b.</p> <p>1 = Tsi350A asserts S_RST_b.</p> <p>When S_RST_b is asserted, the data buffers and the secondary interface are initialized back to reset conditions. The primary interface and configuration registers are not affected by the assertion of S_RST_b.</p> <p>Reset value: 0.</p>	0

Bit	Name	Type	Description	Reset value
23	Fast back-to-back enable	R	Reads as 0 to indicate that Tsi350A does not generate fast back-to-back transactions on the secondary bus.	0
24	Primary master time-out	R/W	<p>Sets the maximum number of PCI clock cycles that Tsi350A waits for an initiator on the primary bus to repeat a delayed transaction request. The counter starts once the delayed transaction completion is at the head of the queue. If the master has not repeated the transaction at least once before the counter expires, Tsi350A discards the transaction from its queues.</p> <p>0 = The primary master time-out value is 2^{15} PCI clock cycles, or 0.983 ms for a 33 MHz bus.</p> <p>1 = The value is 2^{10} PCI clock cycles, or 30.7 ms for a 33 MHz bus.</p> <p>Reset value: 0.</p>	0
25	Secondary master time-out	R/W	<p>Sets the maximum number of PCI clock cycles that Tsi350A waits for an initiator on the secondary bus to repeat a delayed transaction request. The counter starts once the delayed transaction completion is at the head of the queue. If the master has not repeated the transaction at least once before the counter expires, Tsi350A discards the transaction from its queues.</p> <p>0 = The primary master time-out value is 2^{15} PCI clock cycles, or 0.983 ms for a 33 MHz bus.</p> <p>1 = The value is 2^{10} PCI clock cycles, or 30.7 ms for a 33 MHz bus.</p> <p>Reset value: 0.</p>	0
26	Master time-out status	R/W1TC	<p>This bit is set to 1 when either the primary master time-out counter or the secondary master time-out counter expires and a delayed transaction is discarded from Tsi350A's queues. Write 1 to clear.</p> <p>Reset value: 0.</p>	0
27	Master time-out SERR_b enable	R/W	<p>Controls assertion of P_SERR_b during a master timeout.</p> <p>0 = Signal P_SERR_b is not asserted as a result of a master timeout.</p> <p>1 = Signal P_SERR_b is asserted when either the primary master time-out counter or the secondary master time-out counter expires and a delayed transaction is discarded from Tsi350A's queues. The SERR_b enable bit in the command register must also be set.</p> <p>Reset value: 0.</p>	0

Bit	Name	Type	Description	Reset value
31:28	Reserved	R	Reserved. Returns 0 when read.	0

15.3 Device-Specific Configuration Registers

This section provides a detailed description of Tsi350A device-specific configuration registers.

Each field has a separate description. Fields that have the same configuration address are selectable by turning on (driving low) the appropriate byte enable bits on P_CBE_b during the data phase. To select all fields of a configuration address, drive all byte enable bits low.

All reserved fields and registers are read only and always return 0.

15.3.1 Chip Control Register—Offset 0x40

- Dword address = 0x40h
- Byte enable P_CBE_b[3:0] = xxx0b

Bit	Name	Type	Description	Reset Value
0	Reserved	R	Reserved. Returns 0 when read.	0
1	Memory write disconnect control	R/W	Controls when Tsi350A, as a target, disconnects memory write transactions. 0 = Tsi350A disconnects on queue full or on a 4 kB boundary. 1 = Tsi350A disconnects on a cache line boundary, as well as when the queue fills or on a 4 kB boundary. Reset value: 0.	0
3:2	Reserved	R	Reserved. Returns 0 when read.	0
4	Secondary bus prefetch disable	R/W	Controls Tsi350A's ability to prefetch during upstream memory read transactions. 0 = Tsi350A prefetches and does not forward byte enable bits during memory read transactions. 1 = Tsi350A requests only one Dword from the target during memory read transactions and forwards read byte enable bits. Tsi350A returns a target disconnect to the requesting master on the first data transfer. Memory read line and memory read multiple transactions are still prefetchable. Reset value: 0.	0
5	Live insertion mode	R/W	Enables hardware control of transaction forwarding in Tsi350A. 0 = Pin GPIO[3] has no effect on the I/O, memory, and master enable bits. 1 = If the output enable control for GPIO[3] is set to input only in the GPIO output enable control register, this bit enables GPIO[3] to mask the I/O enable, memory enable, and master enable bits to 0. These enable bits are masked when GPIO[3] is driven high. When this occurs, Tsi350A stops accepting I/O and memory transactions. Reset value: 0.	0
7:6	Reserved	R	Reserved. Returns 0 when read.	0

15.3.2 Diagnostic Control Register—Offset 0x40

W1S indicates that writing 1 in this bit position causes a chip reset to occur. Writing 0 has no effect.

- Dword address = 0x40
- Byte enable P_CBE_b[3:0] = xx0xb

Bit	Name	Type	Description	Reset Value
8	Chip reset	R/W1S	Chip and secondary bus reset control. 1 = Causes Tsi350A to perform a chip reset. Data buffers, configuration registers, and both the primary and secondary interfaces are reset to their initial state. Tsi350A clears this bit once chip reset is complete. Tsi350A can then be reconfigured. Secondary bus reset S_RST_b is asserted and the secondary reset bit in the bridge control register is set when this bit is set. The secondary reset bit in the bridge control register must be cleared in order to de-assert S_RST_b.	0
10:9	Test mode	R/W	Controls the testability of Tsi350A's internal counters. These bits are used for chip test only. The value of these bits controls which bytes of the counters are exercised: 00b = Normal functionality—all bits are exercised. 01b = Byte 1 is exercised. 10b = Byte 2 is exercised. 11b = Byte 0 is exercised. Reset value: 00b.	0
15:11	Reserved	R	Reserved. Returns 0 when read.	0

15.3.3 Arbiter Control Register—Offset 0x40

- Dword address = 0x40
- Byte enable P_CBE_b[3:0] = 00xb

Bit	Name	Type	Description	Reset Value
25:16	Arbiter control	R/W	Each bit controls whether a secondary bus master is assigned to the high priority arbiter group or the low priority arbiter group. Bits [24:16] correspond to request inputs S_REQ_b[8:0], respectively. Bit [25] corresponds to Tsi350A as a secondary bus master. 0 = Indicates that the master belongs to the low priority group. 1 = Indicates that the master belongs to the high priority group. Reset value: 10 0000 0000b.	0x200
31:26	Reserved	R	Reserved. Returns 0 when read.	0

15.3.4 Read Transaction Control Register— Offset 0x44

Bit	Name	Type	Description	Reset value
7:6	Downstream Transaction Maximum Prefetch Count	R/W	This register bits designates the maximum prefetch count for downstream Memory Read transactions. 00 = 16 Dwords 01 = 32 Dwords 10 = 48 Dwords 11 = 64 Dwords	0
5:4	Upstream Transaction Maximum Prefetch Count	R/W	This register bits designates the maximum prefetch count for upstream Memory Read transactions. 00 = 16 Dwords 01 = 32 Dwords 10 = 48 Dwords 11 = 64 Dwords	0
3	Reserved	R	N/A	0
2	Downstream Cacheline Prefetch Enable	W	1 = Prefetch occurs for all downstream memory read transactions up to programmed cacheline size boundary or up to 64 bytes boundary incase cacheline size register value is not programmed. 0 = Prefetch occurs for all downstream memory read transactions up to the value programmed at offset 0x44 , bits 7:6	1
1	Upstream Cacheline Prefetch Enable	W	1 = Prefetch occurs for all upstream memory read transactions up to programmed cacheline size boundary or up to 64 bytes boundary incase cacheline size register value is not programmed. 0 = Prefetch occurs for all downstream memory read transactions up to the value programmed at offset 0x44 , bits 5:4	1
0	Non-posted Flush	R/W	1 = Clears the non-posted read completions from the primary interface, in the non-posted buffer, when a posted write is received from primary interface. The read request retry from the secondary device will be registered as a new non-posted read request. 0 = Tsi350A follows PCI Bridge ordering rules.	0

15.3.5 P_SERR_b Event Disable Register—Offset 0x64

- Dword address = 0x64
- Byte enable P_CBE_b[3:0] = xxx0b

Bit	Name	Type	Description	Reset value
0	Reserved	R	Reserved. Returns 0 when read.	0
1	Posted write parity error	R/W	Controls the Tsi350A's ability to assert P_SERR_b when a data parity error is detected on the target bus during a posted write transaction. 0 = Signal P_SERR_b is asserted if this event occurs and the SERR_b enable bit in the command register is set. 1 = Signal P_SERR_b is not asserted if this event occurs. Reset value: 0.	0
2	Posted write non delivery	R/W	Controls the Tsi350A's ability to assert P_SERR_b when it is unable to deliver posted write data after 2 ²⁴ attempts. 0 = Signal P_SERR_b is asserted if this event occurs and the SERR_b enable bit in the command register is set. 1 = Signal P_SERR_b is not asserted if this event occurs. Reset value: 0.	0
3	Target abort during posted write	R/W	Controls the Tsi350A's ability to assert P_SERR_b when it receives a target abort when attempting to deliver posted write data. 0 = Signal P_SERR_b is asserted if this event occurs and the SERR_b enable bit in the command register is set. 1 = Signal P_SERR_b is not asserted if this event occurs. Reset value: 0.	0
4	Master abort on posted write	R/W	Controls the Tsi350A's ability to assert P_SERR_b when it receives a master abort when attempting to deliver posted write data. 0 = Signal P_SERR_b is asserted if this event occurs and the SERR_b enable bit in the command register is set. 1 = Signal P_SERR_b is not asserted if this event occurs. Reset value: 0.	0
5	Delayed write non-delivery	R/W	Controls the Tsi350A's ability to assert P_SERR_b when it is unable to deliver delayed write data after 2 ²⁴ attempts. 0 = Signal P_SERR_b is asserted if this event occurs and the SERR_b enable bit in the command register is set. 1 = Signal P_SERR_b is not asserted if this event occurs. Reset value: 0.	0

Bit	Name	Type	Description	Reset value
6	Delayed read—no data from target	R/W	Controls the Tsi350A's ability to assert P_SERR_b when it is unable to transfer any read data from the target after 2 ²⁴ attempts. 0 = Signal P_SERR_b is asserted if this event occurs and the SERR_b enable bit in the command register is set. 1 = Signal P_SERR_b is not asserted if this event occurs. Reset value: 0.	0
7	Reserved	R	Reserved. Returns 0 when read.	0

15.3.6 GPIO Output Data Register—Offset 0x64

This section describes the GPIO output data register.

- Dword address = 0x64
- Byte enable P_CBE_b[3:0] = xx0xb

Bit	Name	Type	Description	Reset value
11:8	GPIO output write 1 to clear	R/W1C	The GPIO[3:0] pin output data write-1-to-clear. Writing 1 to any of these bits drives the corresponding bit low on the GPIO[3:0] bus if it is programmed as bi-directional. Data is driven on the PCI clock cycle following completion of the configuration write to this register. Bit positions corresponding to GPIO pins that are programmed as input only are not driven. Writing 0 to these bits has no effect. When read, reflects the last value written. Reset value: 0.	0
15:12	GPIO output write 1 to set	R/W1C	The GPIO[3:0] pin output data write-1-to-set. Writing 1 to any of these bits drives the corresponding bit high on the GPIO[3:0] bus if it is programmed as bi-directional. Data is driven on the PCI clock cycle following completion of the configuration write to this register. Bit positions corresponding to GPIO pins that are programmed as input only are not driven. Writing 0 to these bits has no effect. When read, reflects the last value written. Reset value: 0.	0



If both an output-high bit and an output-low bit are set for the same GPIO terminal, the output-low bit takes precedence.

15.3.7 GPIO Output Enable Control Register—Offset 0x64

This section describes the GPIO output enable control register.

- Dword address = 0x64
- Byte enable P_CBE_b[3:0] = x0xxb

Bit	Name	Type	Description	Reset value
19:16	GPIO output enable write 1 to clear	R/W1C	The GPIO[3:0] output enable control write-1-to clear. Writing 1 to any of these bits configures the corresponding GPIO[3:0] pin as an input only; that is, the output driver is tristated. Writing 0 to this register has no effect. When read, reflects the last value written. Reset value: 0 (all pins are input only).	0
23:20	GPIO output enable write 1 to set	R/W1C	The GPIO[3:0] output enable control write-1-to set. Writing 1 to any of these bits configures the corresponding GPIO[3:0] pin as bi-directional, that is, enables the output driver and drives the value set in the output data register (65h). Writing 0 to this register has no effect. When read, reflects the last value written. Reset value: 0 (all pins are input only).	0



If both an output enable bit and an input enable bit are set for the same GPIO terminal, the input enable bit takes precedence.

15.3.8 GPIO Input Data Register—Offset 0x64

- Dword address = 0x64
- Byte enable P_CBE_b[3:0] = 0xxx b

Bit	Name	Type	Description	Reset value
27:24	Reserved	R	Reserved. Returns 0 when read.	0
31:28	GPIO input	R	This read-only register reads the state of the GPIO[3:0] pins. This state is updated on the PCI clock cycle following a change in the GPIO pins.	Undefined

15.3.9 Secondary Clock Control Register—Offset 0x68

- Dword address = 0x68
- Byte enable P_CBE_b[3:0] = xx00b

Bit	Name	Type	Description	Reset value
1:0	S_CLKOUT0 disable	R/W	00, 01, 10 = S_CLKOUT0 enabled (00 is the default). 11 = S_CLKOUT0 disabled and driven high.	0
3:2	S_CLKOUT1 disable	R/W	00, 01, 10 = S_CLKOUT1 enabled (00 is the default). 11 = S_CLKOUT1 disabled and driven high.	0
5:4	S_CLKOUT2 disable	R/W	00, 01, 10 = S_CLKOUT2 enabled (00 is the default). 11 = S_CLKOUT2 disabled and driven high.	0
7:6	S_CLKOUT3 disable	R/W	00, 01, 10 = S_CLKOUT3 enabled (00 is the default). 11 = S_CLKOUT3 disabled and driven high.	0
8	S_CLKOUT4 disable	R/W	0 = S_CLKOUT4 enabled (default). 1 = S_CLKOUT4 disabled and driven high.	0
9	S_CLKOUT5 disable	R/W	0 = S_CLKOUT5 enabled (default). 1 = S_CLKOUT5 disabled and driven high.	0
10	S_CLKOUT6 disable	R/W	0 = S_CLKOUT6 enabled (default). 1 = S_CLKOUT6 disabled and driven high.	0
11	S_CLKOUT7 disable	R/W	0 = S_CLKOUT7 enabled (default). 1 = S_CLKOUT7 disabled and driven high.	0
12	S_CLKOUT8 disable	R/W	0 = S_CLKOUT8 enabled (default). 1 = S_CLKOUT8 disabled and driven high.	0
13	S_CLKOUT9 disable	R/W	0 = S_CLKOUT9 enabled (default). 1 = S_CLKOUT9 disabled and driven high.	0
15:14	Reserved	R	Reserved: Return 0 when read.	0

15.3.10 P_SERR_b Status Register—Offset 0x68

- Dword address = 0x68
- Byte enable P_CBE_b[3:0] = x0xxb

Bit	Name	Type	Description	Reset value
16	Address parity error	R/W1C	1 = Signal P_SERR_b was asserted because an address parity error was detected on either the primary or secondary PCI bus. Reset value: 0.	0
17	Posted write data parity error	R/W1C	1 = Signal P_SERR_b was asserted because a posted write data parity error was detected on the target bus. Reset value: 0.	0
18	Posted write non delivery	R/W1C	1 = Signal P_SERR_b was asserted because the Tsi350A was unable to deliver posted write data to the target after 2 ²⁴ attempts. Reset value: 0.	0
19	Target abort during posted write	R/W1C	1 = Signal P_SERR_b was asserted because the Tsi350A received a target abort when delivering posted write data. Reset value: 0.	0
20	Master abort during posted write	R/W1C	1 = Signal P_SERR_b was asserted because the Tsi350A received a master abort when attempting to deliver posted write data. Reset value: 0.	0
21	Delayed write non delivery	R/W1C	1 = Signal P_SERR_b was asserted because the Tsi350A was unable to deliver delayed write data after 2 ²⁴ attempts. Reset value: 0.	0
22	Delayed read—no data from target	R/W1C	1 = Signal P_SERR_b was asserted because the Tsi350A was unable to read any data from the target after 2 ²⁴ attempts. Reset value: 0.	0
23	Delayed transaction master time-out	R/W1C	1 = Signal P_SERR_b was asserted because a master did not repeat a read or write transaction before the master time-out counter expired on the initiator's PCI bus. Reset value: 0.	0

15.3.11 Capability ID Register—Offset 0xDC

- Dword address = 0xDC
- Byte enable P_CBE_b[3:0] = xxx0b

Bit	Name	Type	Description	Reset value
7:0	CAP_ID	R	Enhanced capabilities ID. Reads only as 0x01 to indicate that these are power management enhanced capability registers.	0x01

15.3.12 Next Item Pointer Register—Offset 0xDD

- Dword address = 0xDC
- Byte enable P_CBE_b[3:0] = xx0xb

Bit	Name	Type	Description	Reset value
15:8	NEXT_ITEM	R	The next-item pointer returns 0xE4 to indicate that Tsi350A supports more than one extended capability.	0xE4

15.3.13 Power Management Capabilities Register—Offset 0xDC

- Dword address = 0xDC
- Byte enable P_CBE_b[3:0] = 00xxb

Bit	Name	Type	Description	Reset value
18:16	PM_VER	R	Power Management Revision. Reads as 001 to indicate that this device is compliant with Revision 1.0 of the PCI Power Management Interface Specification.	001
19	PME_b Clock	R	PME_b Clock Required. Reads as 0 to indicate that this device does not support the PME_b pin.	0
20	AUX	R	Auxiliary Power Support. Reads as 0 to indicate that this device does not have PME_b support or an auxiliary power source.	0
21	DSI	R	Device Specific Initialization. Reads as 0 to indicate that this device does not have device specific initialization requirements.	0
24:22	Reserved	R	Reserved. Read as 000b.	0
25	D1	R	D1 Power State Support. Reads as 0 to indicate that this device does not support the D1 power management state.	0
26	D2	R	D2 Power State Support. Reads as 0 to indicate that this device does not support the D2 power management state.	0
31:27	PME_SUP	R	PME_b Support. Reads as 0 to indicate that this device does not support the PME_b pin.	0

15.3.14 Power Management Control and Status Register—Offset 0xE0

- Dword address = 0xE0
- Byte enable P_CBE_b[3:0] = xx00b

Bit	Name	Type	Description	Reset value
1:0	PWR_STATE	R	Power State. Reflects the current power state of this device. If an unimplemented power state is written to this register, Tsi350A completes the write transaction, ignores the write data, and does not change the value of this field. Writing a value of D0 when the previous state was D3 causes a chip reset to occur (without asserting S_RST_b). 00b = D0 01b = D1 (not implemented) 10b = D2 (not implemented) 11b = D3. Reset value: 00b.	0
7:2	Reserved	R	Reserved. Reads as 000000b.	0
8	PME_EN	R	PME_b Enable. Reads as 0 because the PME_b pin is not implemented.	0
12:9	DATA_SEL	R	Data Select. Reads as 0000b because the data register is not implemented.	0
14:13	DATA_SCALE	R	Data Scale. Reads as 00b because the data register is not implemented.	0
15	PME_STAT	R	PME Status. Reads as 0 because the PME_b pin is not implemented.	0

15.3.15 PPB Support Extensions Registers—Offset 0xE2

- Dword address = 0xE0h
- Byte enable P_CBE_b[3:0] = x0xxb

Bit	Name	Type	Description	Reset value
21:16	Reserved	R	Reserved. Read only as 000000b.	0
22	B2_B3	R	B2_B3 Support for D3hot. When the BPCC_En bit (bit 23) reads as 1, this bit reads as 1 to indicate that the secondary bus clock outputs will be stopped and driven low when this device is placed in D3hot. This bit is not defined when the BPCC_En bit reads as 0.	Undefined
23	BPCC_EN	R	Bus Power/Clock Control Enable. When the BPCCE pin is tied high, this bit reads as a 1 to indicate that the bus power/clock control mechanism is enabled, as described in B2_B3 (bit 22). When the BPCCE pin is tied low, this bit reads as a 0 to indicate that the bus power/clock control mechanism is disabled (secondary clocks are not disabled when this device is placed in D3hot.)	Undefined

15.3.16 Data Register—Offset 0xE3

- Dword address = 0xE0
- Byte enable P_CBE_b[3:0] = 0xxxb

Bit	Name	Type	Description	Reset value
31:24	Data	R	Data register. This register is not implemented and reads 0x00.	0

15.3.17 HS Capability ID Register— Offset 0xE4

Bit	Name	Type	Description	Reset value
7:0	Hot Swap Capability ID	R	Returns 0x06 when read indicating that this register set of the capability list is a Hot Swap Register Set.	0x06

15.3.18 HS Next Item Pointer Register— Offset 0xE5

Bit	Name	Type	Description	Reset value
15:8	Hot Swap Next Pointer	R	Returns 0x00 indicating that there are more list items in the capabilities list.	0

15.3.19 HS Control Status Register— Offset 0xE6

Bit	Name	R/W	Description	Reset value
16	DHA	R/W	<p>Device Hiding Arm</p> <p>When this bit has a value of 1, the Device Hiding will be armed. The device hiding is useful in hiding the device from software during board removal.</p> <p>When this bit is set, the bridge will not respond to any transaction on the PCI bus.</p> <p>The hardware sets this bit after P_RST_b is de-asserted and switch handle is open. The hardware automatically clears this bit after it enters INS state.</p> <p>Reset value: 0</p>	0
17	EIM	R/W	<p>HS_ENUM_b Interrupt Mask</p> <p>This bit allows the HS_ENUM_b pin to be masked by software.</p> <p>Writing 1 to this bit masks the HS_ENUM_b pin from being driven.</p> <p>Writing 0 to this bit will enable HS_ENUM_b to be driven.</p> <p>Reset value: 0</p>	0
18	PIE	R	<p>Pending INS/EXT</p> <p>This two-bit field specifies the programming interface supported by a board. Two programming interfaces are currently defined.</p> <p>Returns 0 when read.</p>	0
19	LOO	R/W	<p>LED On Off</p> <p>This bit controls an external LED indicator for user feedback.</p> <p>When software writes 1 to this register, the LED is illuminated.</p> <p>When a 0 is written to this bit the LED is not illuminated.</p> <p>Reset value: 0</p>	0
21:20	PI	R	<p>Programming Interface</p> <p>This field indicates to software that the bridge would support Device Hiding and Pending INS or EXT.</p> <p>Returns 01 when read.</p>	01
22	EXT	R/W1C	<p>Extraction</p> <p>The bridge sets this bit to indicate software that a board is about to be removed from the system. The bridge asserts HS_ENUM_b when this bit is set.</p> <p>Reset value: 0</p>	0

Bit	Name	R/W	Description	Reset value
23	INS	R/W1C	<p>Insertion</p> <p>The bridge sets this bit to indicate software that a board has been freshly inserted. This bit will be set only after the following events:</p> <ul style="list-style-type: none"> Ejector Handle is closed. P_RST_b de-asserted. The bridge asserts ENUM_b when this bit is set. <p>Reset value: 0</p>	0

A. Package Information

This appendix discusses the following topic:

- “Package Characteristics” on page 169

A.1 Package Characteristics

A.1.1 208-pin PQFP Package

The 208-pin PQFP package figures have symbols that describe measurements of the package. The following table outlines the symbol values.

Table 37: PQFP Symbol Values

Symbol	Millimeter		
	Minimum	Nominal	Maximum
A	-	-	4.10
A1	0.25	-	-
A2	3.20	3.32	3.60
D E	30.60 BSC.		
D1 E1	28.00 BSC.		
R2	0.08	-	0.25
R1	0.08	-	-
Theta	0	3.5	7
Theta1	0	-	-
Theta2 Theta3	8 REF		
c	0.09	0.15	0.20
L	0.45	0.60	0.75
L1	1.30 REF		
S	0.20	-	-
b	0.17	0.20	0.27
e	0.50 BSC.		

Table 37: PQFP Symbol Values

Symbol	Millimeter		
	Minimum	Nominal	Maximum
D2	25.50		
E2	25.50		
aaa	0.20		
bbb	0.20		
ccc	-	0.08	-
ddd	-	0.08	-

Figure 8: 208-pin PQFP Package Diagram - Top View

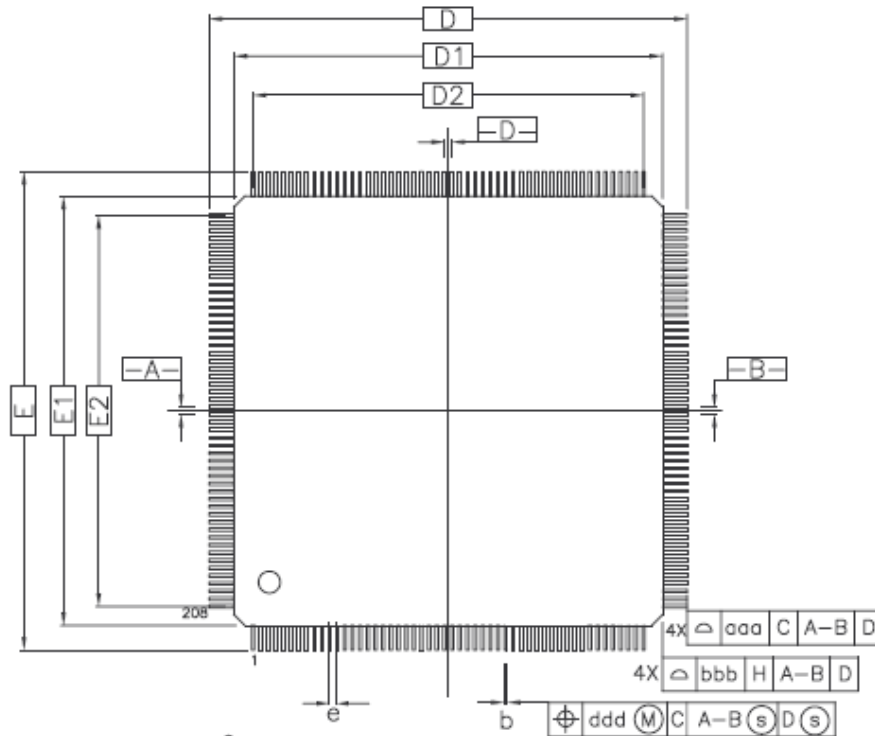

Figure 9: 208-pin PQFP Package Diagram - Side View

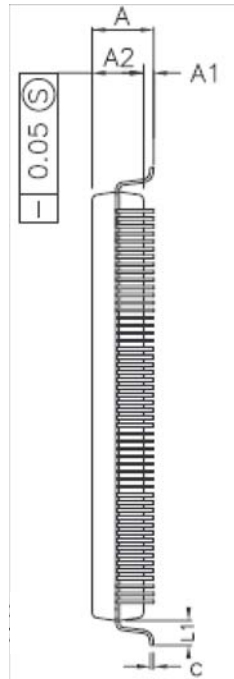
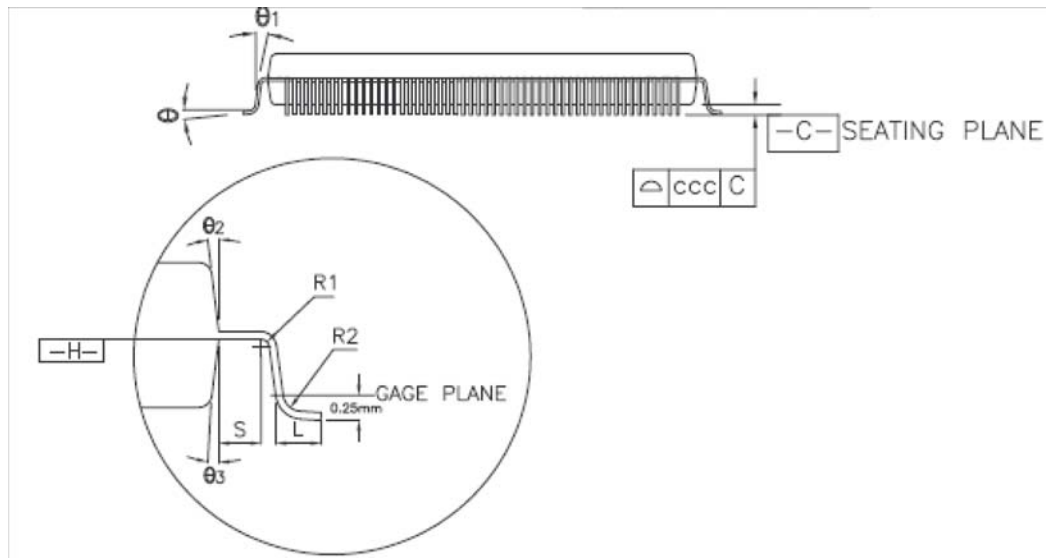

Figure 10: 208-pin PQFP Package Diagram - Side View



A.1.2 256-pin PBGA Package

Figure 11: 256-pin PBGA Package Diagram - Top View

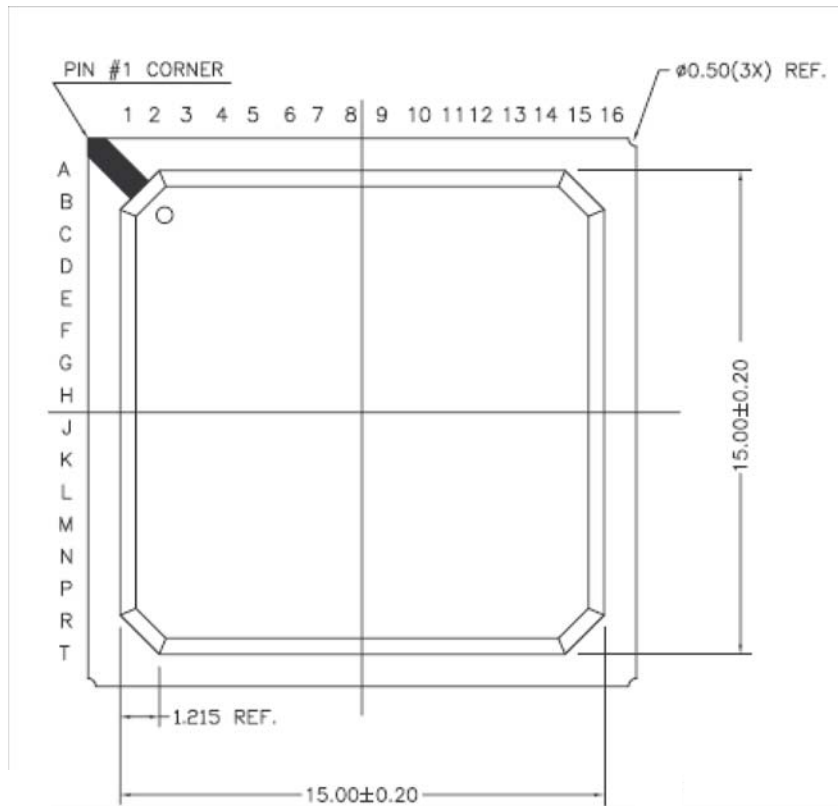

Figure 12: 256-pin PBGA Package Diagram - Bottom View

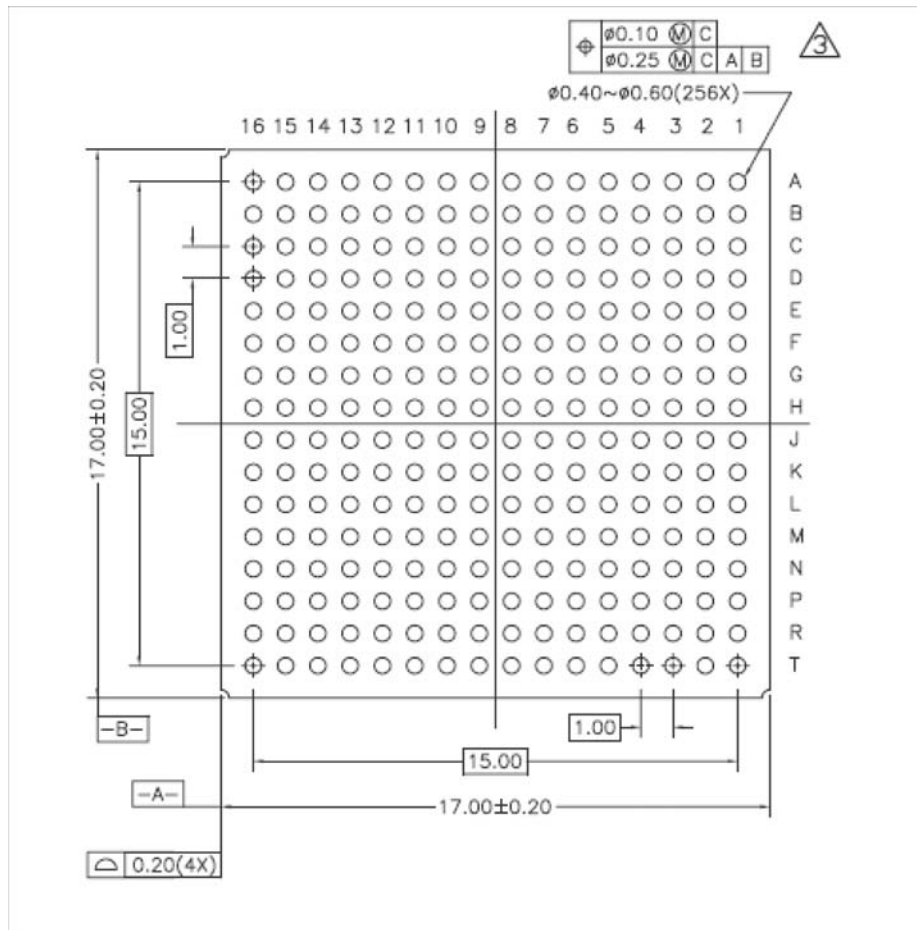
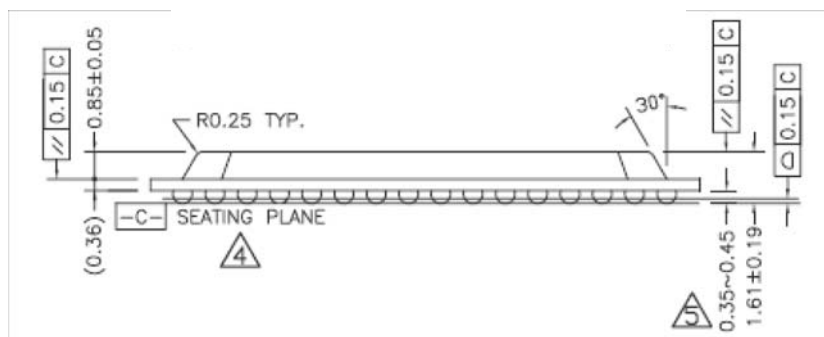

Figure 13: 256-pin PBGA Package Diagram - Side View



A.2 Thermal Characteristics

Heat generated by the packaged IC has to be removed from the package to ensure that the IC is maintained within its functional and maximum design temperature limits. If heat buildup becomes excessive, the IC temperature may exceed the temperature limits. A consequence of this is that the IC may fail to meet the performance specifications and the reliability objectives may be affected.

Failure mechanisms and failure rate of a device have an exponential dependence of the IC operating temperatures. Thus, the control of the package temperature, and by extension the Junction Temperature, is essential to ensure product reliability. The Tsi350A is specified safe for operation when the Junction Temperature is within the recommended limits.

Table 38 shows the simulated Θ_{jb} and Θ_{jc} thermal characteristics of the Tsi350A packages.

Table 38: Thermal Characteristics of the Tsi350A

Interface	Tsi350A PQFP Result	Tsi350A PBGA Result
Θ_{jb} (junction to board)	11.3 °C/watt	11.9 °C/watt
Θ_{jc} (junction to case)	5.1 °C/watt	5.9 °C/watt

A.2.1 Junction-to-Ambient Thermal Characteristics (Θ_{ja})

Table 39 shows the simulated Θ_{ja} thermal characteristic of the Tsi350A PQFP and PBGA packages. The results in Table 39 are based on a JEDEC Thermal Test Board configuration (JESD51-9) and do not factor in system level characteristics. As such, these values are for reference only.



The Θ_{ja} thermal resistance characteristics of a package depend on multiple system level variables (see “System-level Characteristics” on page 175).

Table 39: Simulated Junction to Ambient Characteristics

Package	Θ_{ja} at specified airflow (no Heat Sink)		
	0 m/s	1 m/s	2 m/s
Tsi350A PQFP	14.8 C/watt	12.6 °C/watt	11.7 °C/watt
Tsi350A PBGA	17.2 C/watt	15.2 °C/watt	14.5 °C/watt

A.2.2 System-level Characteristics

The thermal resistance characteristics of a package depend on multiple variables other than the package. In an application, the following system-level characteristics and environmental issues must be taken into account:

- Package mounting (vertical / horizontal)
- System airflow conditions (laminar / turbulent)
- Heat sink design and thermal characteristics
- Heat sink attachment method
- PWB size, layer count and conductor thickness
- Influence of the heat dissipating components assembled on the PWB (neighboring effects)

A.2.3 Example on Thermal Data Usage

Based on the Θ_{JA} data and specified conditions, the following formula can be used to derive the junction temperature (T_j) of the Tsi350A with a 0m/s airflow:

- $T_j = \Theta_{JA} * P + T_{amb}$.

Where: T_j is Junction Temperature, P is the Power consumption, T_{amb} is the Ambient Temperature

Assuming a power consumption (P) of 1 W and an ambient temperature (T_{amb}) of 70°C, the resulting junction temperature (T_j) for the PQFP package would be 84.8°C.

B. Ordering Information

This appendix discusses Tsi350A's ordering information.

B.1 Ordering Information

When ordering the Tsi350A please refer to the device by its full part number, as displayed in [Table 40](#).

Table 40: Ordering Information

Part Number	Temp	Package	Description
Tsi350A-66CQ	Commercial	208-pin PQFP	66 MHz PCI-to-PCI Bridge
Tsi350A-66CQY	Commercial	208-pin PQFP (RoHS)	66 MHz PCI-to-PCI Bridge
Tsi350A-66CLV	Commercial	256-pin BGA (RoHS)	66 MHz PCI-to-PCI Bridge

IMPORTANT NOTICE AND DISCLAIMER

RENESAS ELECTRONICS CORPORATION AND ITS SUBSIDIARIES (“RENESAS”) PROVIDES TECHNICAL SPECIFICATIONS AND RELIABILITY DATA (INCLUDING DATASHEETS), DESIGN RESOURCES (INCLUDING REFERENCE DESIGNS), APPLICATION OR OTHER DESIGN ADVICE, WEB TOOLS, SAFETY INFORMATION, AND OTHER RESOURCES “AS IS” AND WITH ALL FAULTS, AND DISCLAIMS ALL WARRANTIES, EXPRESS OR IMPLIED, INCLUDING, WITHOUT LIMITATION, ANY IMPLIED WARRANTIES OF MERCHANTABILITY, FITNESS FOR A PARTICULAR PURPOSE, OR NON-INFRINGEMENT OF THIRD PARTY INTELLECTUAL PROPERTY RIGHTS.

These resources are intended for developers skilled in the art designing with Renesas products. You are solely responsible for (1) selecting the appropriate products for your application, (2) designing, validating, and testing your application, and (3) ensuring your application meets applicable standards, and any other safety, security, or other requirements. These resources are subject to change without notice. Renesas grants you permission to use these resources only for development of an application that uses Renesas products. Other reproduction or use of these resources is strictly prohibited. No license is granted to any other Renesas intellectual property or to any third party intellectual property. Renesas disclaims responsibility for, and you will fully indemnify Renesas and its representatives against, any claims, damages, costs, losses, or liabilities arising out of your use of these resources. Renesas' products are provided only subject to Renesas' Terms and Conditions of Sale or other applicable terms agreed to in writing. No use of any Renesas resources expands or otherwise alters any applicable warranties or warranty disclaimers for these products.

(Disclaimer Rev.1.0 Mar 2020)

Corporate Headquarters

TOYOSU FORESIA, 3-2-24 Toyosu,
Koto-ku, Tokyo 135-0061, Japan
www.renesas.com

Contact Information

For further information on a product, technology, the most up-to-date version of a document, or your nearest sales office, please visit:
www.renesas.com/contact/

Trademarks

Renesas and the Renesas logo are trademarks of Renesas Electronics Corporation. All trademarks and registered trademarks are the property of their respective owners.