

DO NOT SCALE FROM THIS PRINT

DESIGNED & DIMENSIONED IN INCHES[MILLIMETERS]

PRF35-J-C-EP-402-BS

SERIES  
-35: 3.5mm

GENDER  
-J: JACK

TYPE  
-C: CABLE

TERMINATION  
-S: SOLDER CLAMP

ORIENTATION  
-B: BULKHEAD

CABLE TYPE  
-402: RG-402 SEMI-RIGID

FINISH  
-EP: 50µ" EXTRA HEAVY GOLD CENTER CONTACT, PASSIVATED OUTER CONTACT

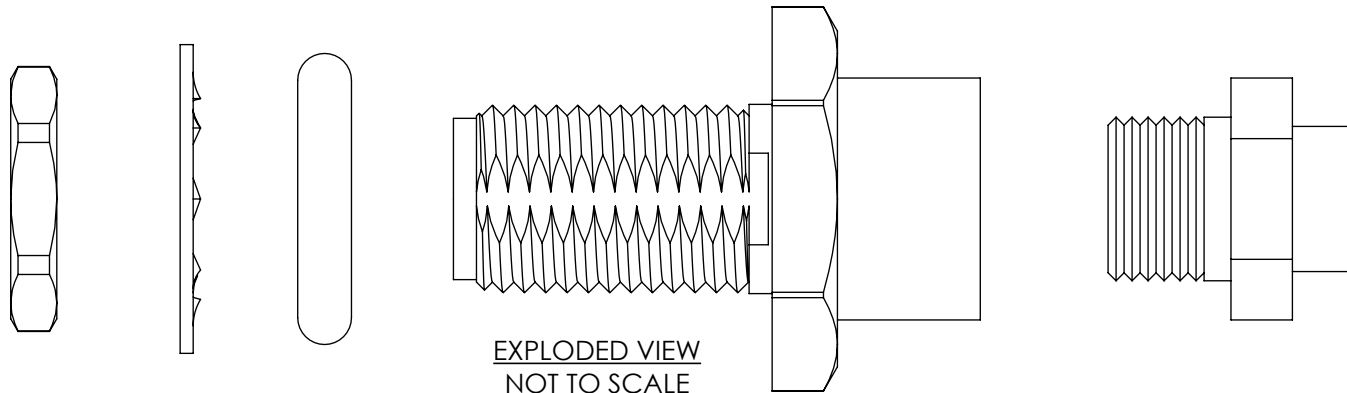
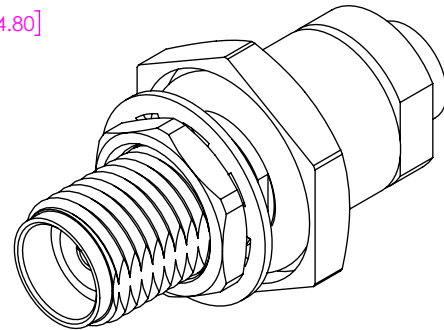
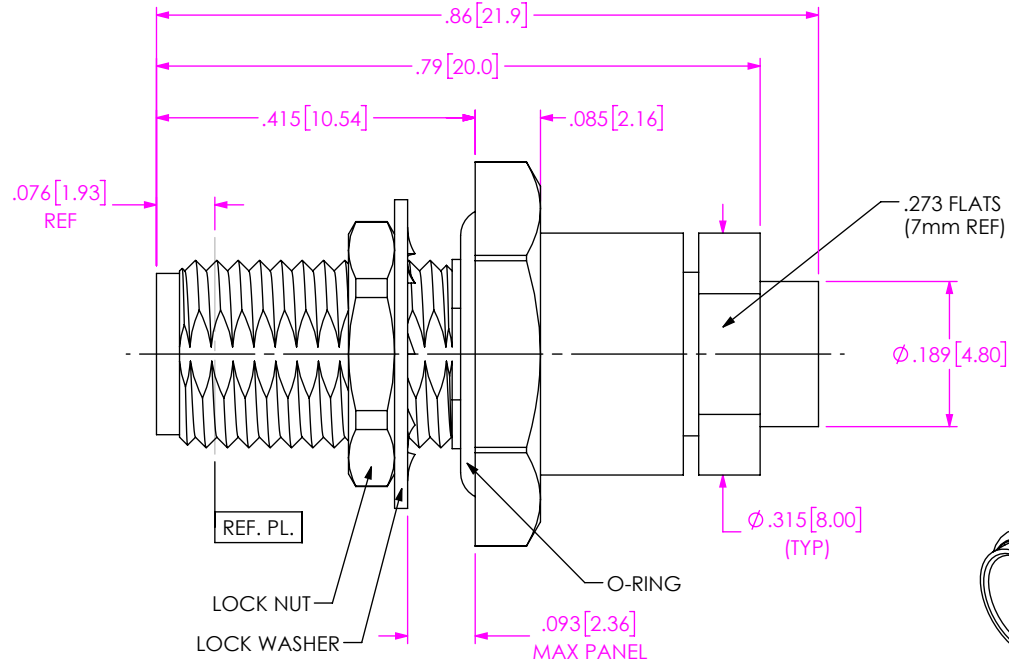

EXPLODED VIEW  
NOT TO SCALE  
(FOR CLARITY ONLY)

F:\DWG\MISC\MKTG\PRF35-J-C-EP-402-BS-MKT.SLDDRW

NOTES:

- MATERIAL:  
BODY, BUSHING, LOCK WASHER, JAM NUT: STAINLESS STEEL  
CONTACT: BERYLLIUM COPPER  
CLAMP NUT: BRASS ALLOY  
BEAD: PCTFE  
O-RING: SILICONE RUBBER
- FINISH:  
BODY, BUSHING, LOCK WASHER, JAM NUT: PASSIVATED  
CLAMP NUT, CONTACT: 50µ" MIN. GOLD OVER 50µ" MIN. NICKEL PLATE
- PCI P/N: 3382

UNLESS OTHERWISE SPECIFIED, DIMENSIONS ARE IN INCHES. TOLERANCES ARE: DECIMALS      ANGLES .XX: ±.01 [0.3]      1 ° .XXX: ±.005 [0.13] .XXXX: ±.0005 [0.013]		<p><b>PROPRIETARY NOTE</b></p> <p>THIS DOCUMENT CONTAINS CONFIDENTIAL AND PROPRIETARY INFORMATION AND ALL DESIGN, MANUFACTURING, REPRODUCTION, USE, PATENT RIGHTS AND SALES RIGHTS ARE EXPRESSLY RESERVED BY SAMTEC, INC. THIS DOCUMENT SHALL NOT BE DISCLOSED, IN WHOLE OR PART, TO ANY UNAUTHORIZED PERSON OR ENTITY NOR REPRODUCED, TRANSFERRED OR INCORPORATED IN ANY OTHER PROJECT IN ANY MANNER WITHOUT THE EXPRESS WRITTEN CONSENT OF SAMTEC, INC.</p>	
MATERIAL: DO NOT SCALE DRAWING	SHEET SCALE: 4:1	 <p>520 PARK EAST BLVD, NEW ALBANY, IN 47150 PHONE: 812-944-6733      FAX: 812-948-5047 e-Mail: info@SAMTEC.com      code 55322</p>	
DESCRIPTION: 3.5 MM BULKHEAD JACK ASSEMBLY		DWG. NO. PRF35-J-C-EP-402-BS	
BY: SAMUEL C 04/12/2019		SHEET 1 OF 2	

# CABLE APPLICATION VIEWS

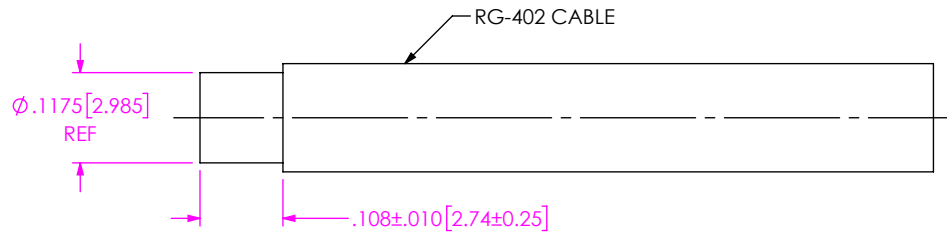

IN-PROCESS VIEW 1

1. TRIM CABLE JACKET TO EXPOSE DIELECTRIC CORE AS SHOWN.

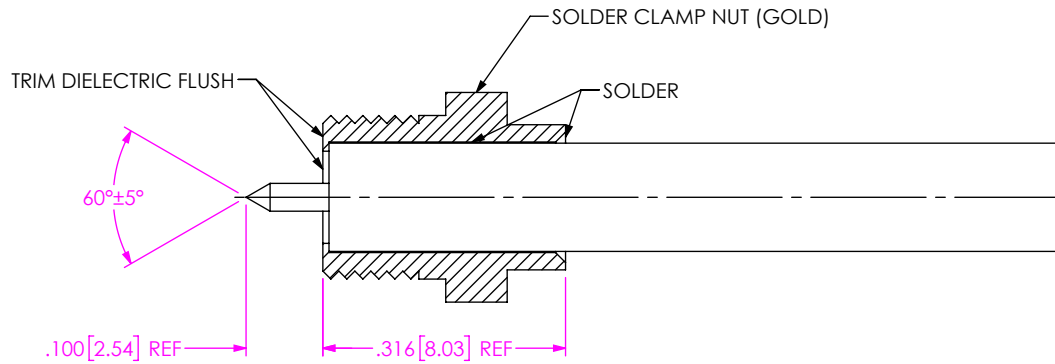

IN-PROCESS VIEW 2

2A. SOLDER CLAMP NUT TO CABLE AS SHOWN.

2B. TRIM CABLE DIELECTRIC FLUSH WITH FACE OF CLAMP NUT AS SHOWN.

2C. POINT CABLE CENTER CONDUCTOR AS SHOWN.

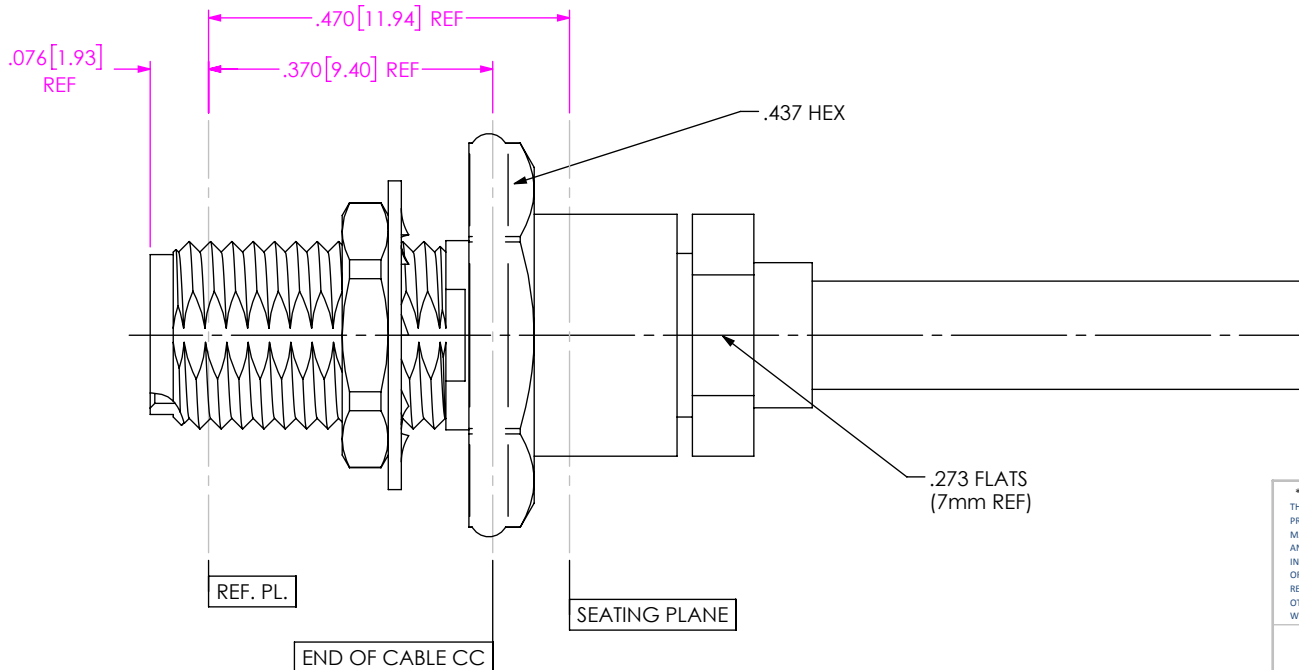

IN-PROCESS VIEW 3

3A. INSERT CABLE SUB-ASSEMBLY INTO CONNECTOR UNTIL SEATED AND TORQUE TO 25-30 IN-LBS.

3B. GAGE CONTACT RECESSON FROM CONNECTOR INTERFACE. (.000/.003 SUB-FLUSH).

**PROPRIETARY NOTE**  
 THIS DOCUMENT CONTAINS CONFIDENTIAL AND PROPRIETARY INFORMATION AND ALL DESIGN, MANUFACTURING, REPRODUCTION, USE, PATENT RIGHTS AND SALES RIGHTS ARE EXPRESSLY RESERVED BY SAMTEC, INC. THIS DOCUMENT SHALL NOT BE DISCLOSED, IN WHOLE OR PART, TO ANY UNAUTHORIZED PERSON OR ENTITY NOR REPRODUCED, TRANSFERRED OR INCORPORATED IN ANY OTHER PROJECT IN ANY MANNER WITHOUT THE EXPRESS WRITTEN CONSENT OF SAMTEC, INC.



520 PARK EAST BLVD, NEW ALBANY, IN 47150  
 PHONE: 812-944-6733 FAX: 812-948-5047  
 e-Mail: info@SAMTEC.com code 55322

DO NOT SCALE DRAWING

SHEET SCALE: 4:1

DESCRIPTION: 3.5 MM BULKHEAD JACK ASSEMBLY

DWG. NO. PRF35-J-C-EP-402-BS

BY: SAMUEL C 04/12/2019 SHEET 2 OF 2