

P/N	Q'TY/REEL	REEL/BOX	SPQ
2130830005	800 PCS	5	4000 PCS

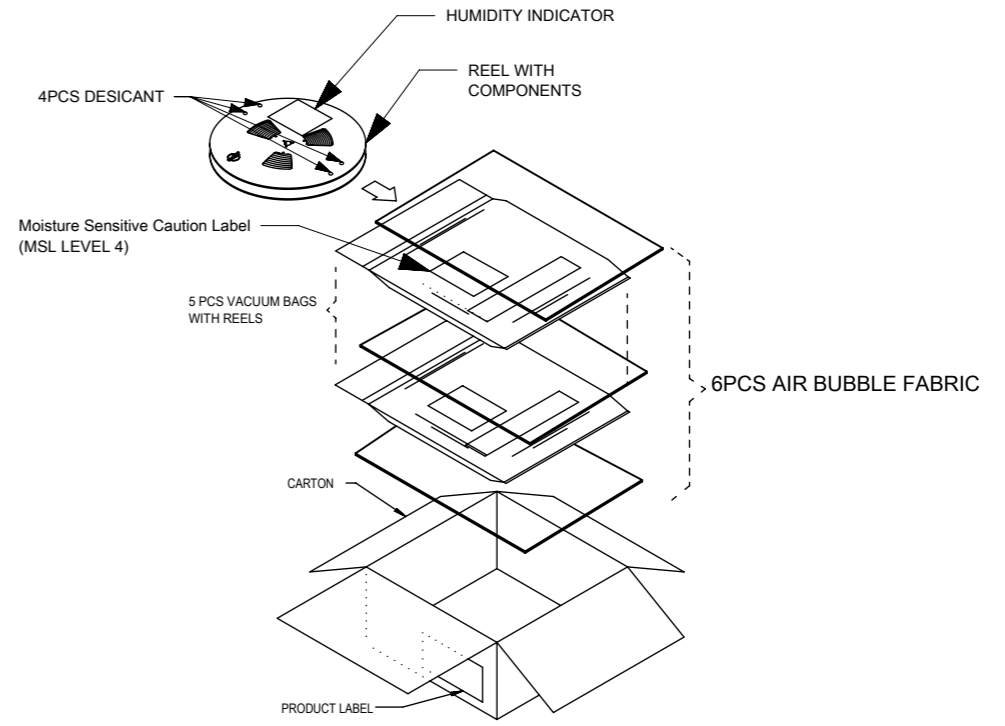

NOTES:

1. PACKING PER 15" REEL, 24mm CARRIER TAPE,
2. THE PEELING FORCE OF CARRIER TAPE :

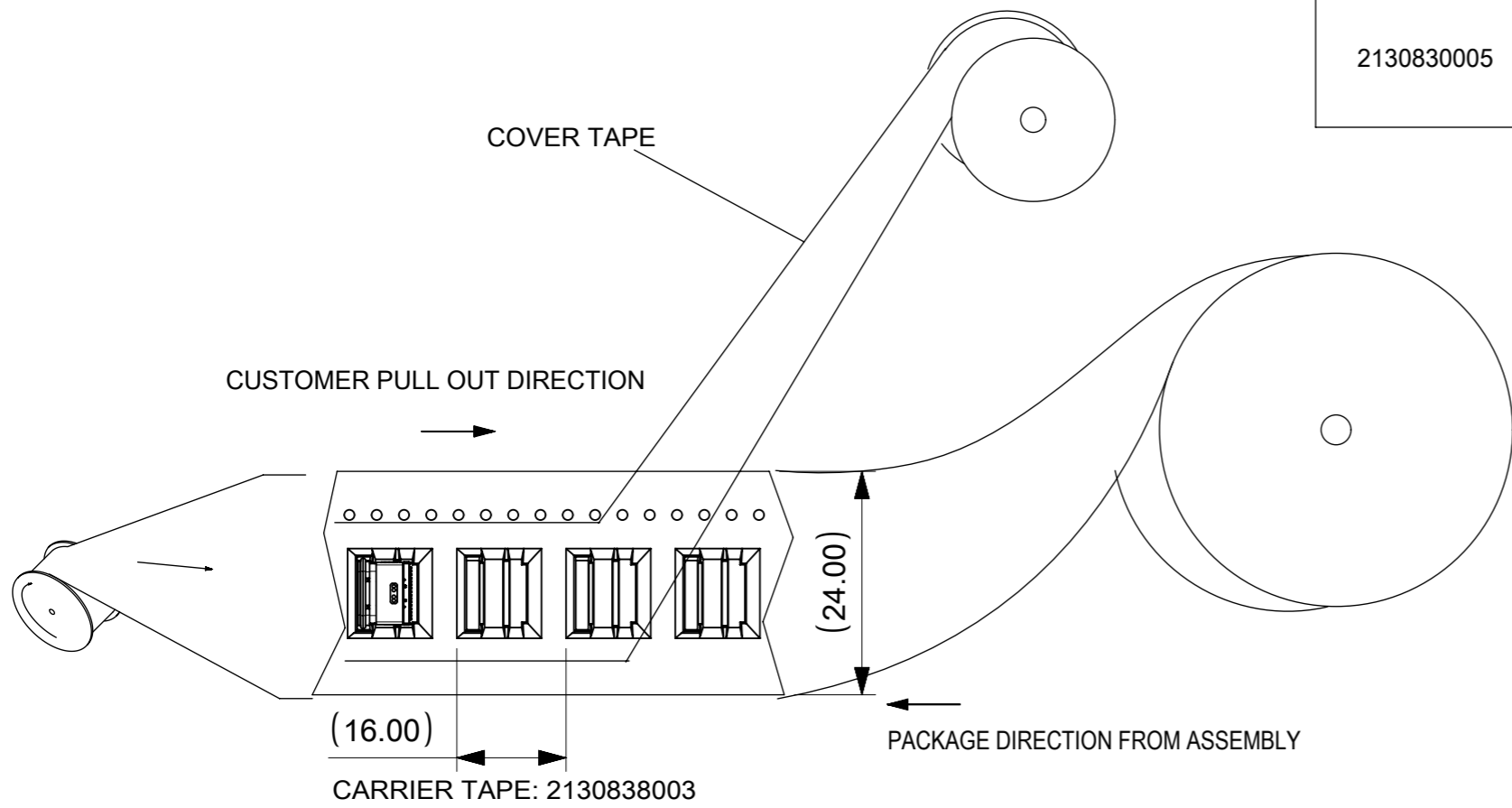
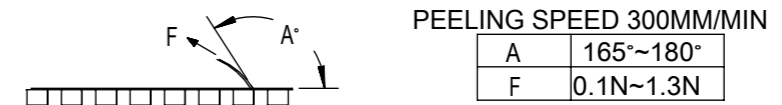

3. USER DIRECTION OF FEED:

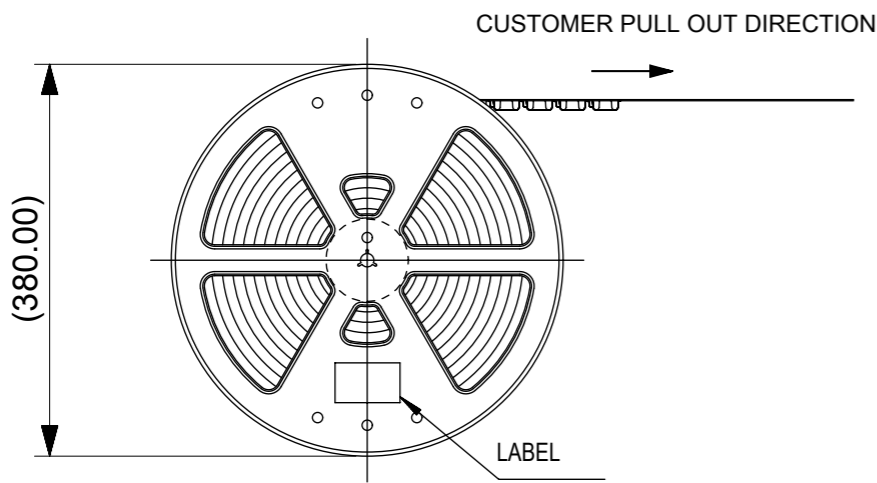
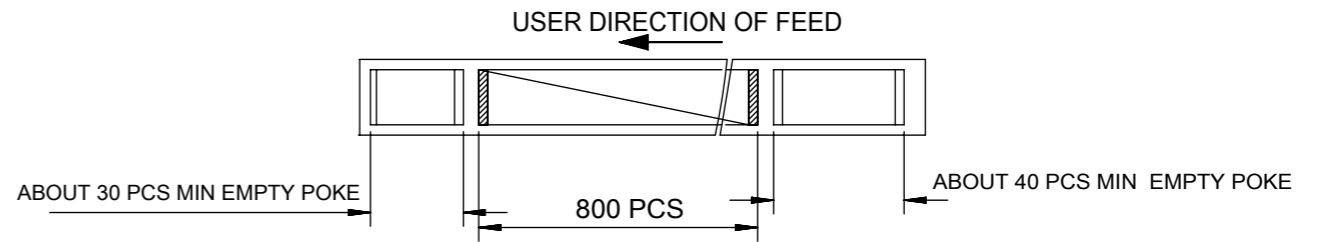

NOTES(Continue)

4. After absorb moisture during shipping, the waterproof function of the product may be affected during the SMT. Proposed the humidity sensitivity level of this product is Level4 refer to IPC/JEDEC J-STD-020D. So it is advised to be used up within 72h after the vacuum packaging is removed.
5. If the package is opened and the color of the humidity indicator changes or the package is damaged, it is recommended to bake Type C connector in the oven at 100°C for 30 minutes. Or bake the Type C connector with reel at 45°C for 8 hours and ensure the humidity within 15%. After repacking, the SMT process can be carried out

SYMBOLS		THIS DRAWING CONTAINS INFORMATION THAT IS PROPRIETARY TO MOLEX ELECTRONIC TECHNOLOGIES, LLC AND SHOULD NOT BE USED WITHOUT WRITTEN PERMISSION		CURRENT REV DESC: CHANGE TO VACUUM PACKAGE		<b>molex</b>	
▽ = 0	mm	SCALE	1:1	PACKAGE			
▽ = 0	GENERAL TOLERANCES (UNLESS SPECIFIED)		EC NO: 739740		2023/02/22		PACKAGE FOR USB-C, RECEPTACLE
▽ = 0	ANGULAR TOL ± 3.0°		DRWN: FYANG05		2023/03/11		
▽ = 0	4 PLACES ±		CHK'D: RLI09		2023/03/11		PACKAGING DESIGN DRAWING
▽ = 0	3 PLACES ± 0.3		APPR: RLI09		2023/03/11		
▽ = 0	2 PLACES ± 0.3		INITIAL REVISION:		DOCUMENT NUMBER		2130830005
▽ = 0	1 PLACE ± 0.3		DRWN: FYANG05		PDD		
▽ = 0	0 PLACES ±		APPR: XQZHANG		PK0		B
▽ = 0	DRAFT WHERE APPLICABLE MUST REMAIN WITHIN DIMENSIONS		THIRD ANGLE PROJECTION		SERIES		
▽ = 0			DRAWING		MATERIAL NUMBER		2130830005
		A3-SIZE		CUSTOMER			
		213083		SHEET NUMBER		1 OF 1	