

IS31BL3230 8 CHANNELS CONSTANT CURRENT LED DRIVER

DESCRIPTION

The IS31BL3230 provides eight regulated current sources; each delivers up to 40mA of load current with careful selection of external sense resistors, all outputs at the IS31BL3230 may be connected in parallel to enable the current through the LED to be as high as 320mA.

Brightness can be controlled with PWM techniques. The constant current source is set with two external sense resistors.

FEATURES

- Ultra low headroom voltage
- Cost effective LED driver
- Current adjustable via external resistors
- Best Noise and Efficiency Performance
- Highly integrated design, minimal component
- 1.6µA (typ.) Shutdown current
- Small package QFN-16 3mm×3mm

QUICK START

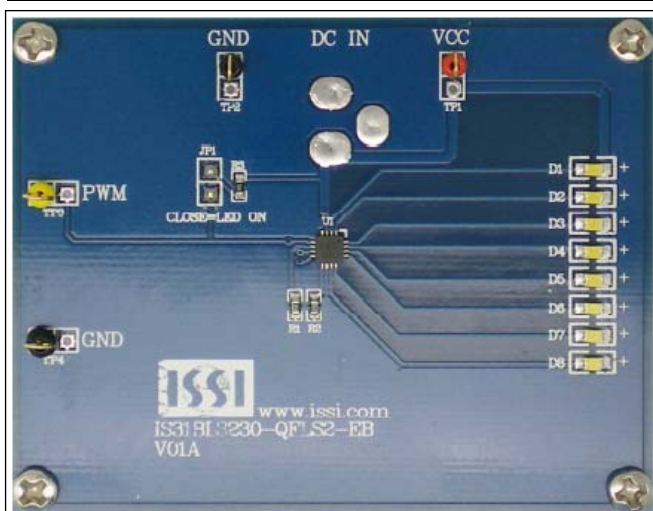

Figure 1: Photo of IS31BL3230 Evaluation Board

RECOMMENDED EQUIPMENT

- 5.0V, 2A power supply

ABSOLUTE MAXIMUM RATINGS

- ≤ 5.5V power supply

Caution: Do not exceed the conditions listed above, otherwise the board will be damaged.

PROCEDURE

The IS31BL3230 evaluation board is fully assembled and tested. Follow the steps listed below to verify board operation.

Caution: Do not turn on the power supply until all connections are completed.

- 1) Connect the ground terminal of the power supply to the GND and the positive terminal to the VCC. Or connect the DC power to the connector (DC IN).
- 2) Turn on the power supply and pay attention to the supply current. If the current exceeds 300mA, please check for circuit fault.
- 3) Close Jumper (JP1) and white LEDs will on.

OUTPUT CURRENT SETTING

The IS31BL3230 evaluation board output current is set with two external sense resistors (R1, R2). As approximated with the following the equation:

$$R_{SET1,2} = 100 \times (V_{ISET1,2} / I_{LEDX})$$

R₂ determines the constant current output of ports D1 thru D4, R₁ determines the constant current output of ports D5 thru D8, V_{ISET} is the voltage of R_{SET} resistance, it is 1.20V typically.

SOFTWARE SUPPORT

JP1 is set to close circuit by default. If it is set to open, the onboard MCU will stop working. The MCU pin to drive the PWM pin will set to High Impedance. An external driving signal can be connected the the TP3 connecting pint to control the IS31BL3230 LED driver chip.

Refer to the datasheet for more information about how to control the IS31BL3230 LED driver.

IS31BL3230 8 CHANNELS CONSTANT CURRENT LED DRIVER

ORDERING INFORMATION

Part No.	Temperature Range	Package
IS31BL3230-QFLS2-EB	-40°C ~ +85°C (Industrial)	QFN-16, Lead-free

Table1: Ordering Information

For pricing, delivery, and ordering information, please contact Lumissil's analog marketing team at analog@lumissil.com or (408) 969-6600.

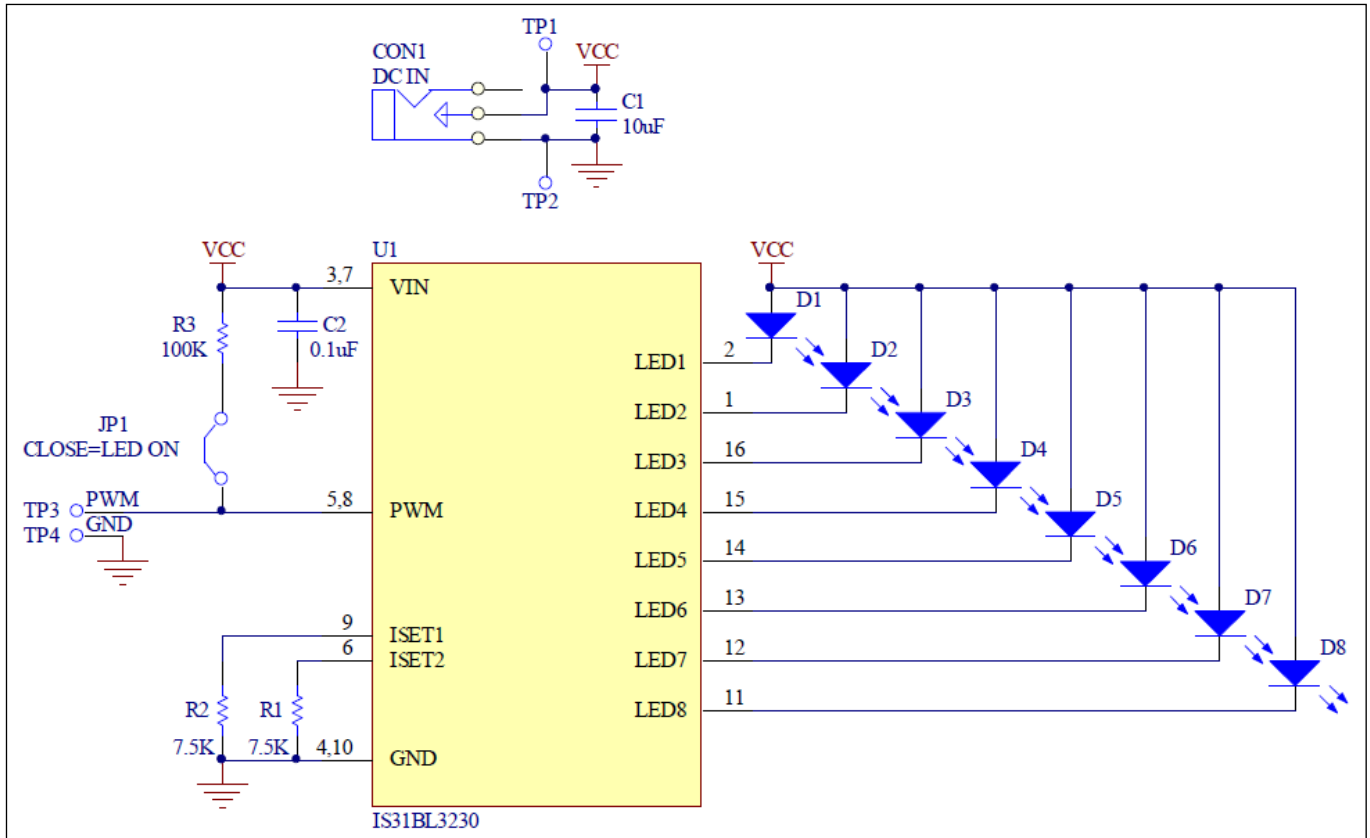

Figure 2: IS31BL3230 Application Schematic

IS31BL3230 8 CHANNELS CONSTANT CURRENT LED DRIVER

Bill of Materials

Name	Symbol	Description	Qty	Supplier	Part No.
LED Driver	U1	8 channels LED Driver	1	Lumissil	IS31BL3230
Diode	D1~D8	Diode, LED White, SMD	8	Everlight	EHP-C04/UT01-P01/TR
Resistor	R1,R2	RES,7.5k,1/16W,±5%,SMD	2		
Resistor	R3	RES,100k,1/16W,±5%,SMD	1		
Capacitor	C1	CAP,10µF,16V,±20%,SMD	1		
Capacitor	C2	CAP,0.1µF,16V,±20%,SMD	1		

Bill of materials, refer to Figure 2 above.

IS31BL3230 8 CHANNELS CONSTANT CURRENT LED DRIVER

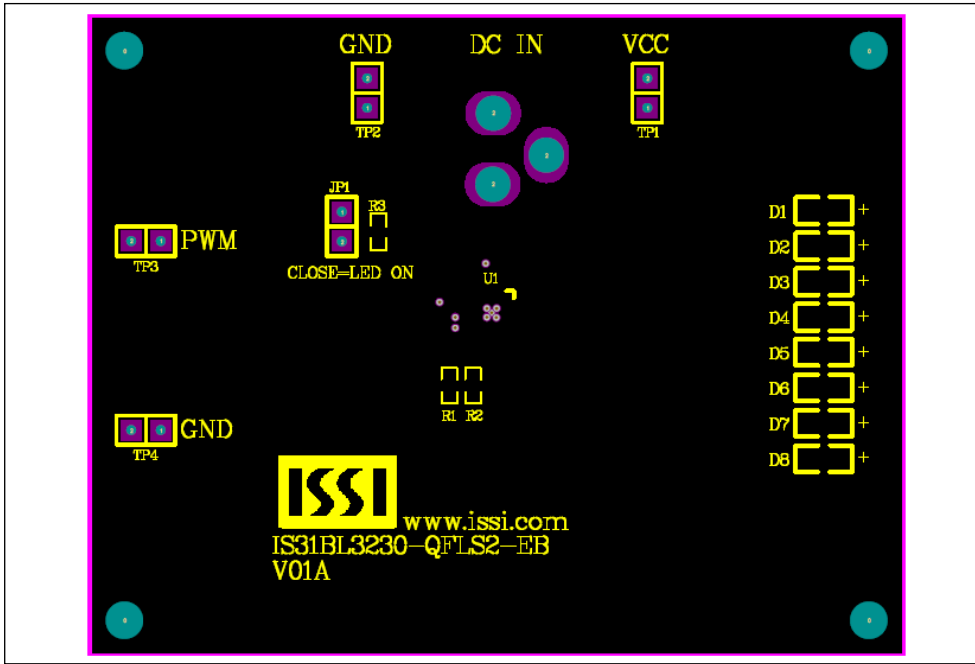

Figure 3: Board Component Placement Guide -Top Layer

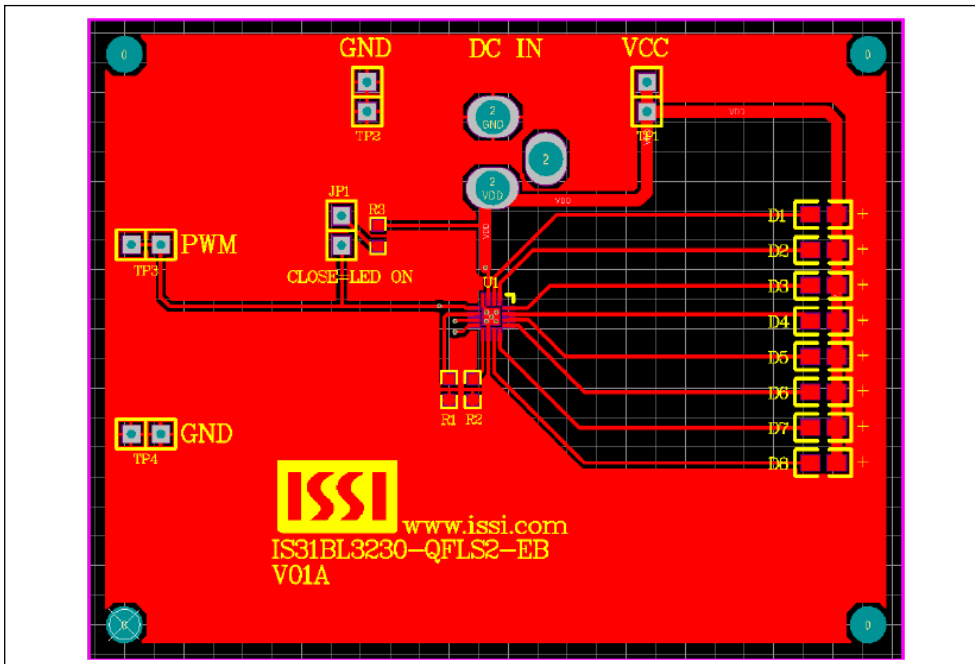

Figure 4: Board PCB Layout- Top Layer

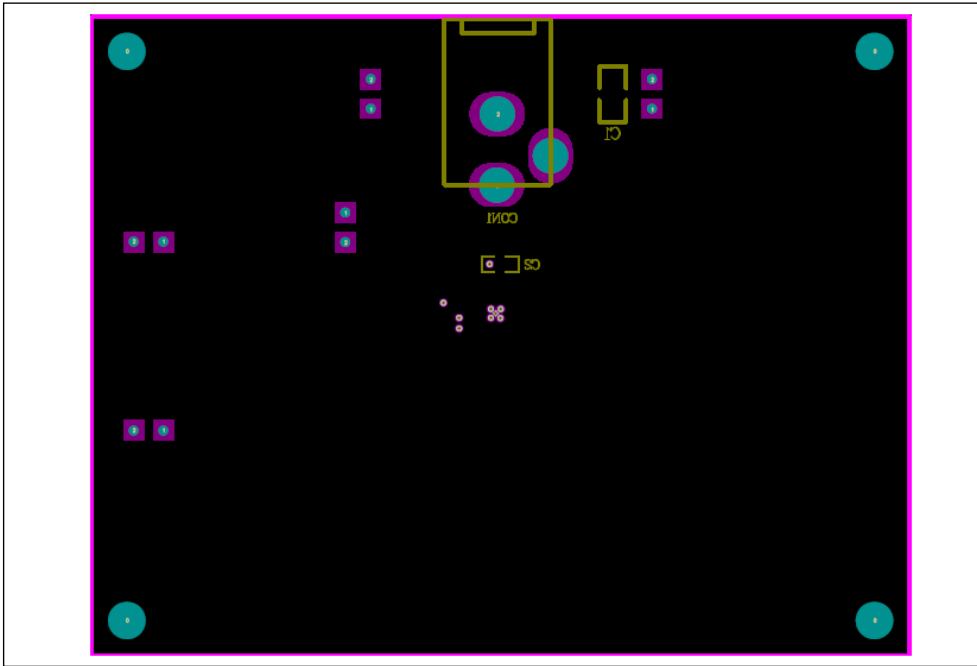

Figure 5: Board Component Placement Guide -Bottom Layer

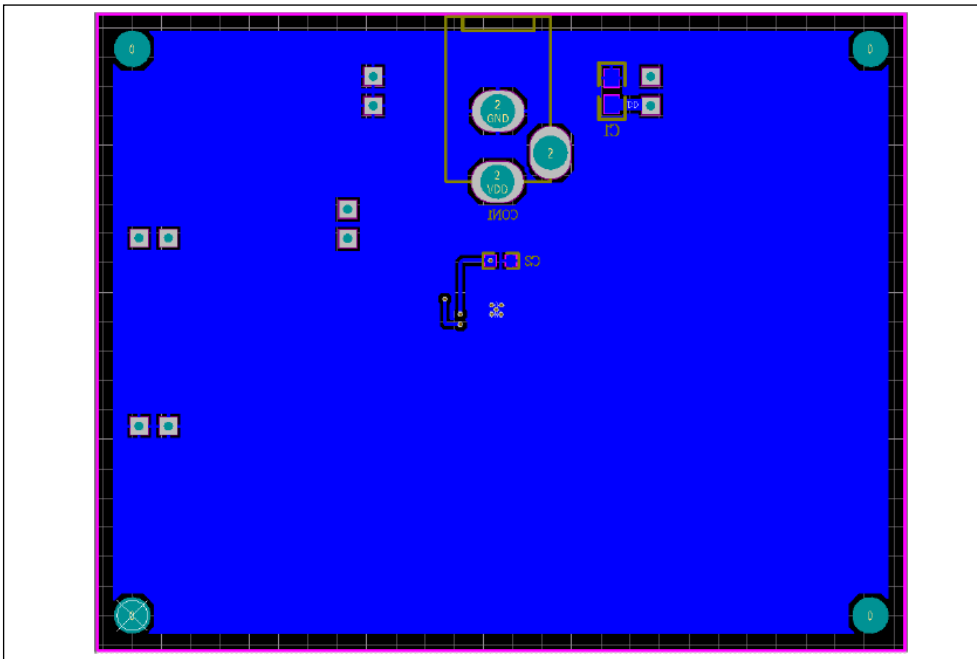

Figure 6: Board PCB Layout-Bottom Layer

Copyright © 2012 Lumissil Microsystems. All rights reserved. Lumissil Microsystems reserves the right to make changes to this specification and its products at any time without notice. Lumissil Microsystems assumes no liability arising out of the application or use of any information, products or services described herein. Customers are advised to obtain the latest version of this device specification before relying on any published information and before placing orders for products.

Lumissil Microsystems does not recommend the use of any of its products in life support applications where the failure or malfunction of the product can reasonably be expected to cause failure of the life support system or to significantly affect its safety or effectiveness. Products are not authorized for use in such applications unless Lumissil Microsystems receives written assurance to its satisfaction, that:

- a.) the risk of injury or damage has been minimized;
- b.) the user assume all such risks; and
- c.) potential liability of Lumissil Microsystems is adequately protected under the circumstances